

**SKYTRAK™**

---

# **Operation & Safety Manual**

*Original Instructions -  
Keep this manual with the machine at all times.*

**Model  
6036, 6042, 8042,  
10042, 10054, 12054**

**PVC 2205**

**31211849**

**October 17, 2022 - Rev B**

**ANSI**

**JLG®**  
An Oshkosh Corporation Company

---

## **WARNING**

Operating, servicing and maintaining this vehicle or equipment can expose you to chemicals including engine exhaust, carbon monoxide, phthalates, and lead, which are known to the State of California to cause cancer and birth defects or other reproductive harm. To minimize exposure, avoid breathing exhaust, do not idle the engine except as necessary, service your vehicle or equipment in a well-ventilated area and wear gloves or wash your hands frequently when servicing. For more information go to [www.P65Warnings.ca.gov](http://www.P65Warnings.ca.gov).

## REVISION LOG

DATE	REVISION	DESCRIPTION
May 16, 2022	A	Original Issue of Manual.
October 17, 2022	B	Revision of Manual.

**This Page is intentionally left blank**

# READ THIS FIRST

This manual is a very important tool! Keep it with the machine at all times.

The purpose of this manual is to provide owners, users, operators, lessors, and lessees with the precautions and operating procedures essential for the safe and proper machine operation for its intended purpose.

Due to continuous product improvements, JLG Industries, Inc. reserves the right to make specification changes without prior notification. Contact JLG Industries, Inc. for updated information.

Refer to [www.JLG.com](http://www.JLG.com) for Warranty, Product Registration, and other machine-related documentation.

## Operator Qualifications

The operator of the machine must not operate the machine until this manual has been read, training is accomplished and operation of the machine has been completed under the supervision of an experienced and qualified operator. Operation within the U.S.A. requires training per OSHA 1910.178.

Operators of this equipment must possess a valid, applicable driver's license, be in good physical and mental condition, have normal reflexes and reaction time, good vision and depth perception and normal hearing. Operator must not be using medication which could impair abilities nor be under the influence of alcohol or any other intoxicant during the work shift.

In addition, the operator must read, understand and comply with instructions contained in the following material furnished with the material handler:

- This Operation & Safety Manual
- Telehandler Safety Manual (ANSI only)
- All instructional decals and plates
- Any optional equipment instructions furnished

The operator must also read, understand and comply with all applicable Employer, Industry and Governmental rules, standards and regulations.

## **Modifications**

**Modifications to this machine may affect compliance with Industry Standards and/or Governmental Regulations. Any modification must be approved by JLG.**

This product must comply with all safety related bulletins. Contact JLG Industries, Inc. or the local authorized JLG representative for information regarding safety-related bulletins which may have been issued for this product.

JLG Industries, Inc. sends safety related bulletins to the owner of record of this machine. Contact JLG Industries, Inc. to ensure that the current owner records are updated and accurate.

JLG Industries, Inc. must be notified immediately in all instances where JLG products have been involved in an accident involving bodily injury or death of personnel or when damage has occurred to personal property or the JLG product.

### **FOR:**

- Accident Reporting and Product Safety Publications
- Current Owner Updates
- Questions Regarding Product Applications and Safety
- Standards and Regulations Compliance Information
- Questions Regarding Product Modifications

### **CONTACT:**

Product Safety and Reliability Department

JLG Industries, Inc.

13224 Fountainhead Plaza

Hagerstown, MD 21742

USA

or Your Local JLG Office

### **In USA:**

Toll Free: 1-877-JLG-SAFE (1-877-554-7233)

### **Outside USA:**

Phone: +1-717-485-6591

### **E-mail:**

ProductSafety@JLG.com

## Other Publications Available

Service Manual .....	31211850
Parts Manual	
6036 .....	31211851
6042 .....	31211852
8042 .....	31211853
10042 .....	31211854
10054 .....	31211855
12054 .....	31211856

**Note:** Refer to the machine Serial Number Plate to identify the applicable compliance standard.

**This Page is intentionally left blank**



# SECTION CONTENTS

Section	Subject	Page
<b>REVISION LOG</b>		<b>3</b>
<b>READ THIS FIRST</b>		<b>5</b>
<b>SECTION 1</b>		
<b>GENERAL SAFETY PRACTICES</b>		<b>13</b>
1.1	Hazard Classification System	13
1.2	General Precautions	13
1.3	Operation Safety	14
1.4	Clearsky (If Equipped)	23
<b>SECTION 2</b>		
<b>PRE-OPERATION AND INSPECTION</b>		<b>25</b>
2.1	Preparation, Inspection and Maintenance	25
2.2	Pre-Operation Check and Inspection	25
2.3	Safety Decals	26
2.4	Walk-Around Inspection	35
2.5	Warm-Up and Operational Checks	37
2.6	Cab	38
2.7	Windows	38
<b>SECTION 3</b>		
<b>CONTROLS AND INDICATORS</b>		<b>41</b>
3.1	General	41
3.2	Controls	41
3.3	Steer Modes	55
3.4	Stabil-Trak™ System (6042, 8042, 10042, 10054 & 12054)	57
3.5	Boom/Outrigger Interlock System (10054 & 12054)	57
3.6	Operator Seat	58
3.7	Boom Angle and Extension Indicators	60
3.8	Reverse Systems (if equipped)	60

<b>SECTION 4</b>	
<b>OPERATION.....</b>	<b>63</b>
4.1	Engine..... 63
4.2	After-Treatment System (ATS) (if equipped for ULS/85 or 110HP) ..... 66
4.3	Operating With A Non-Suspended Load..... 68
4.4	Operating With A Suspended Load..... 69
4.5	Loading and Securing For Transport ..... 72
<b>SECTION 5</b>	
<b>ATTACHMENTS.....</b>	<b>75</b>
5.1	Approved Attachments..... 75
5.2	Unapproved Attachments ..... 76
5.3	Fork Mounted Attachments..... 76
5.4	Equivalent Load ..... 78
5.5	JLG Supplied Attachments..... 80
5.6	Telehandler/Attachment/Fork Capacity ..... 83
5.7	Use of the Capacity Chart..... 83
5.8	Attachment Installation..... 89
5.9	Adjusting/Moving Forks..... 90
5.10	Attachment Operation ..... 91
<b>SECTION 6</b>	
<b>EMERGENCY PROCEDURES .....</b>	<b>129</b>
6.1	Towing A Disabled Product ..... 129
6.2	Emergency Lowering Of Boom..... 129
6.3	EMERGENCY EXIT FROM ENCLOSED CAB ..... 130
<b>SECTION 7</b>	
<b>LUBRICATION AND MAINTENANCE .....</b>	<b>131</b>
7.1	Introduction..... 131
7.2	General Maintenance Instructions ..... 132
7.3	Maintenance Schedules ..... 132
7.4	LUBRICATION SCHEDULES..... 137
7.5	OPERATOR MAINTENANCE INSTRUCTIONS..... 140
<b>SECTION 8</b>	
<b>ADDITIONAL CHECKS.....</b>	<b>147</b>
8.1	STABIL-TRAK (6042, 8042, 10042, 10054 & 12054) ..... 147
8.2	BOOM/OUTRIGGER INTERLOCK (10054 & 12054)..... 148

8.3 Reverse Sensing System (If Equipped) ..... 150  
8.4 Air Shutoff Valve (ASOV) (If Equipped)..... 151

**SECTION 9  
SPECIFICATIONS..... 153**

9.1 Product Specifications ..... 153

**This Page is intentionally left blank**

# SECTION 1

## General Safety Practices

---

### 1.1 HAZARD CLASSIFICATION SYSTEM

---

#### 1.1.1 Safety Alert System and Safety Signal Words

## DANGER

**DANGER** indicates an imminently hazardous situation which, if not avoided, will result in death or serious injury.

## WARNING

**WARNING** indicates a potentially hazardous situation which, if not avoided, could result in death or serious injury.

## CAUTION

**CAUTION** indicates a potentiality hazardous situation which, if not avoided, may result in minor or moderate injury.

### 1.2 GENERAL PRECAUTIONS

---

## WARNING

Before operation, read and understand this manual. Failure to comply with the safety precautions listed in this manual could result in machine damage, property damage, personal injury or death.

- Hydraulic cylinders are subject to thermal expansion and contraction. This may result in changes to the boom and/or attachment position while the machine is stationary. Factors affecting thermal movement can include the length of time machine is stationary, hydraulic oil temperature, ambient air temperature and boom and/or attachment position.
- Precautions to avoid all hazards in the work area must be taken by the user before and during operation of the machine.

## 1.3 OPERATION SAFETY

**Note:** The manufacturer has no direct control over machine application and operation. Therefore, safety issues listed in this manual are non-exhaustive. The user and operator are responsible for conforming with good safety practices.

### 1.3.1 Electrical Hazards

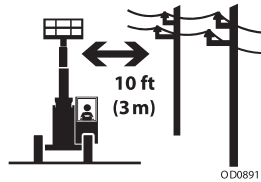

- This machine is not insulated and does not provide protection from contact or being near electrical current.
- Always check for power lines before raising the boom.
- Maintain distance from electrical lines, apparatus, or any energized (exposed or insulated) parts according to the Minimum Approach Distance (MAD).

Voltage Range (Phase to Phase)	Minimum Approach Distance (MAD)
0 to 50 KV	10 ft (3 m)
Over 50KV to 200 KV	15 ft (5 m)
Over 200 KV to 350 KV	20 ft (6 m)
Over 350 KV to 500 KV	25 ft (8 m)
Over 500 KV to 750 KV	35 ft (11 m)
Over 750 KV to 1000 KV	45 ft (14 m)

**Note:** This requirement shall apply except where employer, local or governmental regulations are more stringent.

- Allow for machine movement and electrical line swaying.
- Maintain a clearance of at least 10 ft (3m) between any part of the machine and its occupants, their tools and their equipment from any electrical line or apparatus carrying up to 50,000 volts. One foot additional clearance is required for every additional 30,000 volts or less.

- The minimum approach distance may be reduced if insulating barriers are installed to prevent contact, and the barriers are rated for the voltage of the line being guarded. These barriers shall not be part of (or attached to) the machine. The minimum approach distance shall be reduced to a distance within the designed working dimensions of the insulating barrier. This determination shall be made by a qualified person in accordance with the employer, local, or governmental requirements for work practices near energized equipment.

⚠ DANGER

Do not maneuver machine or personnel inside prohibited zone (MAD). Assume all electrical parts and wiring are energized unless known otherwise.

### 1.3.2 Tip Over Hazard

#### General

- For additional load requirements, refer to the appropriate capacity chart.

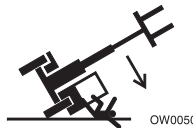

- Never use an attachment without the appropriate original equipment manufacturer (OEM) approved capacity chart installed on the telehandler.
- Understand how to properly use the capacity charts located in cab.
- DO NOT** exceed rated lift capacity.
- Be sure that the ground conditions are able to support the machine.
- Be aware of wind conditions. Wind may cause load swing and dangerous side loads.
- Keep the machine a minimum of 2 ft (0,6 m) from holes, drop-offs, obstructions, debris, concealed holes and other potential hazards at ground level.

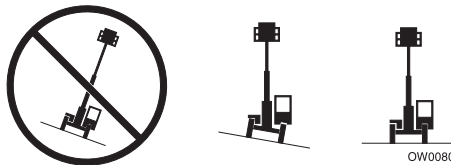

- DO NOT** raise boom unless frame is level (0 degrees), unless otherwise noted on capacity chart.

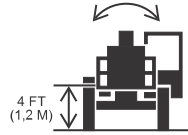
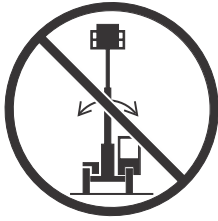

OW0100

- **DO NOT** level machine with boom/attachment above 4 ft (1,2 m). (AUS - **DO NOT** level machine with load more than 11.8 in (300 mm) above ground surface.)

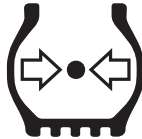

OH2291

- **MAINTAIN proper tire pressure** at all times. If proper tire pressures are not maintained, this machine could tip over.
- Refer to manufacturer's specifications for proper fill ratio and pressure requirements for tires equipped with ballast.



OH20911

- Always wear seat belt.
- Keep head, arms, hands, legs and all other body parts inside operator's cab at all times.



OH2221

If telehandler starts to tip over:

- **DO NOT JUMP**
- **BRACE YOURSELF** and **STAY WITH THE MACHINE**
- **KEEP YOUR SEAT BELT FASTENED**
- **HOLD ON FIRMLY**
- **LEAN AWAY FROM THE POINT OF IMPACT**



## Non-Suspended Load



OD0901

- **DO NOT** drive with boom raised.

## Suspended Load



OW0150

- Tether suspended loads to restrict movement.
- Weight of all rigging (slings, etc.) must be included as part of load.
- **DO NOT** attempt to use telehandler frame-leveling to compensate for load swing.
- Keep heavy part of load closest to attachment.
- Never drag the load; lift vertically.

When driving with a suspended load:

- Start, travel, turn and stop slowly to prevent load from swinging.
- **DO NOT** extend boom.
- **DO NOT** raise the load more than 300 mm (11.8 in) above ground surface or the boom more than 45°.
- **DO NOT** exceed walking speed.

### 1.3.3 Travel Hazard

2-Wheel Front Steer

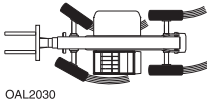

4-Wheel Circle Steer

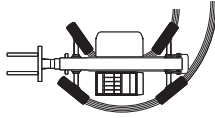

4-Wheel Crab Steer

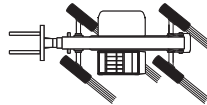

- Steering characteristics differ between steer modes. Identify the steer mode settings of the telehandler being operated.
- **DO NOT** change steer modes while traveling. Steer modes must be changed while telehandler is stationary.
- Visually verify proper wheel alignment after each steer mode change.
- Ensure that adequate clearance is provided for both rear tail swing and front fork swing.
- Look out for and avoid other personnel, machinery and vehicles in the area. Use a spotter if you DO NOT have a clear view.
- Before moving be sure of a clear path and sound horn.
- When driving, retract boom and keep boom/attachment as low as possible while maintaining visibility of mirrors and maximum visibility of path of travel.
- Always look in the direction of travel.
- Always check boom clearances carefully before driving underneath overhead obstructions. Position attachment/load to clear obstacles.
- When driving in high speed, use only front wheel steer (if steering modes are selectable).
- Telehandlers equipped with solid or foam filled tires should not be used in applications requiring excessive roading or driving extended distances. In the event an application requires excessive roading or driving expanded distances, it is recommended to use telehandlers not equipped with solid or foam filled tires.

### 1.3.4 Load Falling Hazard



- Never suspend load from forks or other parts of carriage weldment. Use only approved lift points.
- **DO NOT** burn or drill holes in fork(s).
- Forks must be centered under load and spaced apart as far as possible.

### 1.3.5 Lifting Personnel



- When lifting personnel, **USE ONLY** an approved personnel work platform, with proper capacity chart displayed in the cab.



- **DO NOT** drive machine from cab when personnel are in platform.

### 1.3.6 Driving Hazards on Slopes

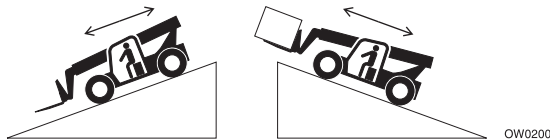

To maintain sufficient traction and braking capabilities, travel on slopes as follows:

- When unloaded, drive with forks pointed downhill.
- When loaded, drive with the forks pointed uphill.
- For additional travel requirements, refer to the appropriate capacity chart.

## General Safety Practices

---

- To avoid overspeeding the engine and drivetrain when driving down slopes, downshift to a lower gear and use the service brake as necessary to maintain a slow speed. **DO NOT shift into neutral and coast downhill.**
- Avoid excessively steep slopes or unstable surfaces. To avoid tip over **DO NOT** drive across excessively steep slopes under any circumstances.
- Avoid turning on a slope. Never engage “inching” or shift to “Neutral” when going downhill.
- **DO NOT** park on a slope.

### 1.3.7 Pinch Points and Crush Hazards

Stay clear of pinch points and rotating parts on the telehandler.

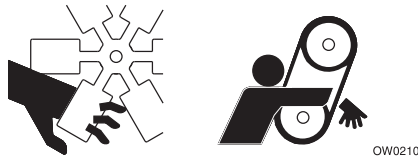

- Stay clear of moving parts while engine is running.



- Keep clear of steering tires and frame or other objects.



- Keep clear from under boom.



- Keep clear of boom holes.



OW0250

- Keep arms and hands clear of attachment tilt cylinder.



OW0260

- Keep hands and fingers clear of carriage and forks.

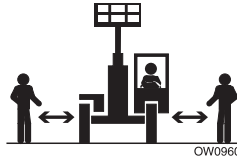

OW0960

- Keep others away while operating.

### 1.3.8 Fall Hazard



OW0280

- Enter using the proper hand holds and steps provided. Always maintain 3-point contact when mounting or dismounting. Never grab control levers or steering wheel when mounting or dismounting the machine.
- **DO NOT** get off the machine until the [Shut-Down Procedure](#) has been performed.



OW0290

- **DO NOT** carry riders. Riders could fall off machine causing death or serious injury.

### 1.3.9 Chemical Hazards

#### Exhaust Fumes

- **DO NOT** operate machine in an enclosed area without proper ventilation.
- **DO NOT** operate the machine in hazardous environments unless approved for that purpose by JLG and site owner. Sparks from the electrical system and the engine exhaust can cause an explosion.

#### Flammable Fuel



- **DO NOT** fill the fuel tank or service the fuel system near an open flame, sparks or smoking materials. Engine fuel is flammable and can cause a fire and/or explosion.

#### Hydraulic Fluid



- **DO NOT** attempt to repair or tighten any hydraulic hoses or fittings while the engine is running or when the hydraulic system is under pressure.
- Stop engine and relieve trapped pressure. Fluid in the hydraulic system is under enough pressure that it can penetrate the skin.
- **DO NOT** use your hand to check for leaks. Use a piece of cardboard or paper to search for leaks. Wear gloves to protect hands from spraying fluid.

---

## 1.4 CLEARSKY (IF EQUIPPED)

---

### 1.4.1 Federal Communications Commission (FCC) Information for Users

#### FCC Statement Regarding Interference

This equipment has been tested and found to comply with the limits for a Class B digital device, pursuant to Part 15 of the FCC Rules. These limits are designed to provide reasonable protection against harmful interference in a residential installation. This equipment generates, uses and can radiate radio frequency energy and, if not installed and used in accordance with the instructions, may cause harmful interference to radio communications. However, there is no guarantee that interference will not occur in a particular installation. If this equipment does cause harmful interference to radio or television reception, which can be determined by turning the equipment off and on, the user is encouraged to try to correct the interference by one or more of the following measures:

- Reorient or relocate the receiving antenna.
- Increase the separation between the equipment and receiver.
- Connect the equipment into an outlet on a circuit different from that to which the receiver is connected.
- Consult the dealer or an experienced radio/TV technician for help.

This device complies with Part 15 of the FCC Rules. Operation is subject to the following two conditions: (1) this device may not cause harmful interference, and (2) this device must accept any interference received, including interference that may cause undesired operation.

Changes or modifications not expressly approved by the party responsible for compliance could void the user's authority to operate the equipment.

#### Notice Regarding Radio Frequency Radiation Exposure

Do not operate your unit when a person is within eight inches (20 centimeters) of the antenna. A person or object within eight inches (20 centimeters) of the antenna could impair call quality and may cause the unit to operate at a higher power level than necessary, as well as expose that person to RF energy in excess of that established by the FCC RF Exposure Guidelines.

**Important:** The unit must be installed in a manner that provides a minimum separation distance of eight inches (20 centimeters) or more between the antenna and persons and just not be co-located or operate in conjunction with any other antenna or transmitter in order to satisfy FCC RF exposure requirements for mobile transmitting devices.

**Important:** To comply with the FCC RF exposure limits and to satisfy the categorical exclusion requirements for mobile transmitters, the requirements described in the following section, "Antenna Installation", must be met.

### Antenna Installation

A minimum separation distance of eight inches (20 centimeters) must be maintained between the antenna and all persons.

The combined cable loss and antenna gain must not exceed +7.5 dBi (850 band). The combined cable loss and antenna gain must not exceed +2.5 dBi and total system output must not exceed 2.0W EIRP in the PCS (1900) band in order to comply with the EIRP limit of 24.232 (b). OEM installers must be provided with antenna installation instruction and transmitter operating conditions for satisfying RF exposure compliance.



# SECTION 2

## Pre-Operation and Inspection

### 2.1 PREPARATION, INSPECTION AND MAINTENANCE

The following table covers the periodic machine inspections and maintenance required. Consult local regulations for further requirements for telehandlers. The frequency of inspections and maintenance must be increased as necessary when the machine is used in a harsh or hostile environment, if the machine is used with increased frequency, or if the machine is used in a severe manner.

Inspection and Maintenance				
Type	Frequency	Primary Responsibility	Service Qualification	Reference
Pre-Operation Inspection	Beginning of each work shift or at each change of operator.	User or Operator	User or Operator	Operation & Safety Manual
Pre-Delivery Inspection (see note)	Before each sale, lease or rental delivery.	Owner, Dealer or User	Qualified Mechanic	Service Manual and applicable Inspection form.
Preventative Maintenance	At intervals as specified in the Service Manual and/ or the Maintenance Charts located on the machine.	Owner, Dealer or User	Qualified Mechanic	Service Manual and Maintenance Charts

**Note:** Inspection forms are available.

### 2.2 PRE-OPERATION CHECK AND INSPECTION

**Note:** Complete all required maintenance before operating unit.

## WARNING

**FALL HAZARD.** Use extreme caution when checking items beyond your normal reach. Use an approved ladder.

The pre-operation check and inspection, performed at beginning of each work shift or at each change of operator, should include the following:

1. **Cleanliness** - Check all surfaces for leakage (oil, fuel or battery fluid) or foreign objects. Report any leakage to the proper maintenance personnel.
2. **Structure** - Inspect the machine structure for dents, damage, weld or parent metal cracks or other discrepancies.



3. **Safety Decals** - Ensure all safety decals are legible and in place. Clean or replace as required. See [Section — Safety Decals](#) for details.
4. **Operation and Safety Manuals** - Operation & Safety Manual and AEM Safety Manual (ANSI only) located in cab manual holder.
5. **Walk-Around Inspection** - See [Section — Walk-Around Inspection](#) for details.
6. **Fluid Levels** - Check fluids, including fuel, diesel exhaust fluid (DEF), hydraulic oil, engine oil and coolant. When adding fluids, refer to [Section — Lubrication and Maintenance](#) and [Section — Specifications](#) to determine proper type and intervals. Before removing filler caps or fill plugs, wipe all dirt and grease away from the ports. If dirt enters these ports, it can severely reduce component life.
7. **Attachments/Accessories** - Ensure correct capacity charts are installed on telehandler. If provided, reference Operation & Safety Manual of each attachment or accessory installed for specific inspection, operation and maintenance instructions.
8. **Operational Check** - Once the walk-around inspection is complete, perform a warmup and operational check (see [Section — Warm-Up And Operational Checks](#)) of all systems in an area free of overhead and ground level obstructions. See [Section — Controls and Indicators](#) for more specific operating instructions.

## WARNING

If telehandler does not operate properly, immediately bring machine to a stop, lower boom and attachment to ground and stop the engine. Determine cause and correct before continued use.

### 2.3 SAFETY DECALS

---

Ensure all **DANGER, WARNING, CAUTION** and instructional decals and proper capacity charts are legible and in place. Clean and replace as required.

### 2.3.1 ANSI (If equipped)

1706850-ENGLISH  
1001163304-ENGLISH/FRENCH  
1001235803-ENGLISH/SPANISH



1706306-ENGLISH  
1001163285-ENGLISH/FRENCH  
1001235801-ENGLISH/SPANISH



1706299-ENGLISH  
1001163210-ENGLISH/FRENCH  
1001235797-ENGLISH/SPANISH



CAPACITY CHARTS



1001162734

1001218659-ENGLISH  
1001219211-ENGLISH/FRENCH,  
ENGLISH/SPANISH  
(INSIDE OF RESERVOIR COVER)



1001227077  
(IF EQUIPPED)

1001162737  
(10042, 10054 & 12054)



1001125387-ENGLISH  
1001163355-  
ENGLISH/FRENCH  
1001235804-  
ENGLISH/SPANISH



1001120989  
(IF EQUIPPED)



4107971-ENGLISH  
1001187239-ENGLISH/FRENCH  
1001242122-ENGLISH/SPANISH  
(10042, 10054 & 12054)

1001162736

1001162735

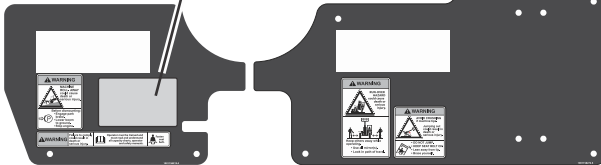

1001158319-ENGLISH  
1001180176-ENGLISH/FRENCH  
1001242173-ENGLISH/SPANISH

1001158272-ENGLISH  
1001180175-ENGLISH/FRENCH  
1001242172-ENGLISH/SPANISH

ASOV TEST  
1001227964  
(IF EQUIPPED)

OH5516

# Pre-Operation and Inspection

1706298-ENGLISH  
 1001163206-ENGLISH/FRENCH  
 1001235796-ENGLISH/SPANISH

1001160072-ENGLISH  
 1001160945-ENGLISH/FRENCH  
 1001237846-ENGLISH/SPANISH  
 (IF EQUIPPED WITH REVERSE SENSING SYSTEM)

1706301-ENGLISH  
 1001163222-ENGLISH/FRENCH  
 1001235799-ENGLISH/SPANISH

1001189328  
 (10054 & 12054)

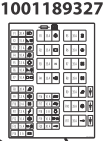

4107442  
**A B C D E F G H**

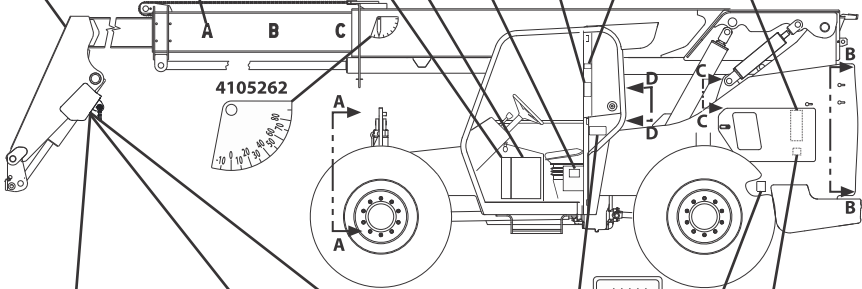

1001207217-ENGLISH

1001210581-  
 ENGLISH/FRENCH  
 1001242179-  
 ENGLISH/SPANISH

1001210582-  
 ENGLISH/FRENCH  
 1001246078-  
 ENGLISH/SPANISH

(IF EQUIPPED WITH BOOM  
 MOUNTED LIFTING LUG)



1702300

1001202626 (74HP)-  
 ENGLISH,  
 ENGLISH/FRENCH  
 1001236313 (74HP)-  
 ENGLISH/SPANISH  
 1001173423 (85HP)  
 1001173422 (110HP)-  
 ENGLISH,  
 ENGLISH/FRENCH  
 1001236312 (110HP)-  
 ENGLISH/SPANISH

OH5527

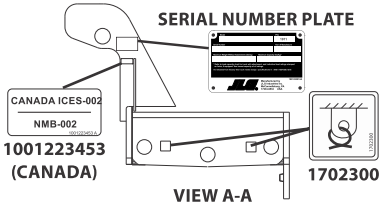

1706296-ENGLISH  
1001163174-ENGLISH/FRENCH  
1001235794-ENGLISH/SPANISH

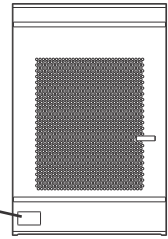

VIEW B-B

1706300-ENGLISH  
1001163212-ENGLISH/FRENCH  
1001235798-ENGLISH/SPANISH

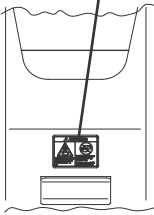

VIEW C-C

1001160071-ENGLISH  
1001160787-ENGLISH/FRENCH  
1001237845-ENGLISH/SPANISH  
(IF EQUIPPED WITH LATCH WINDOW)

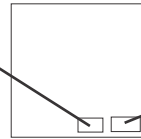

VIEW D-D

91404299-  
(IF EQUIPPED WITH  
FIXED WINDOW)



OH5891

# Pre-Operation and Inspection

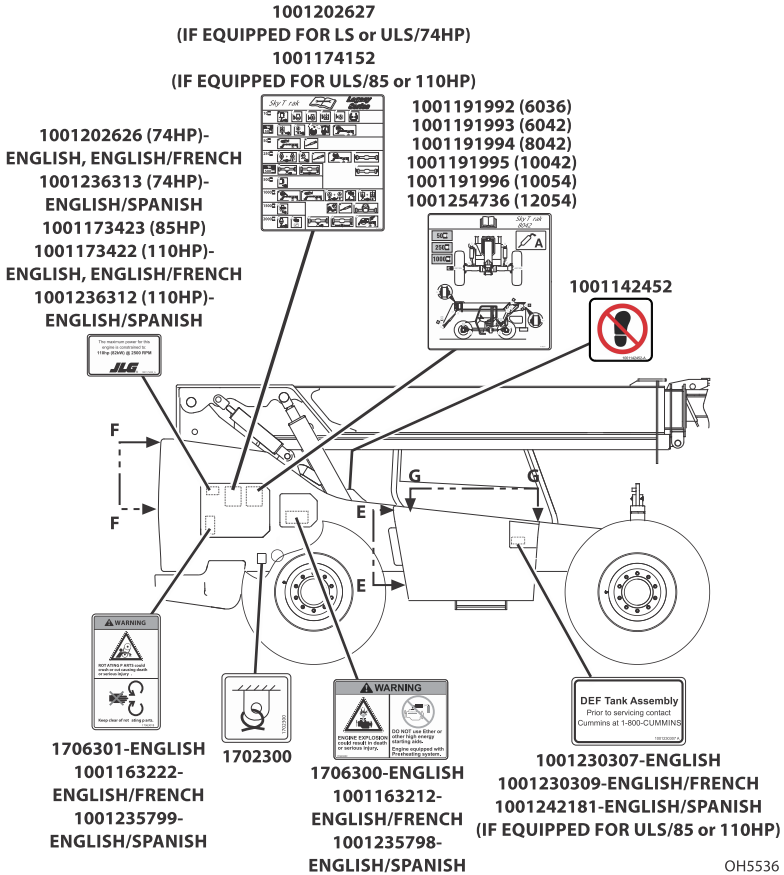

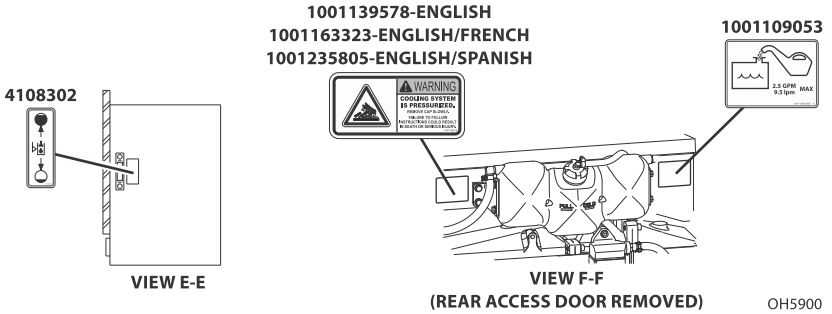
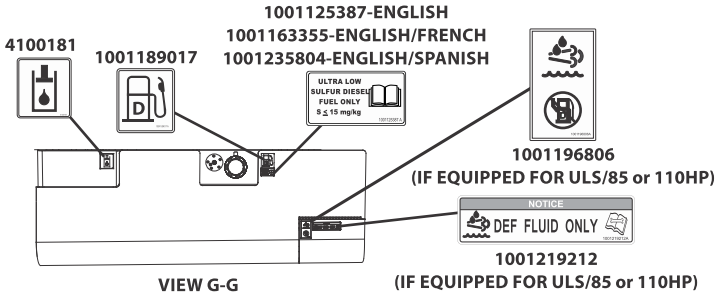

### 2.3.2 ISO (If equipped)

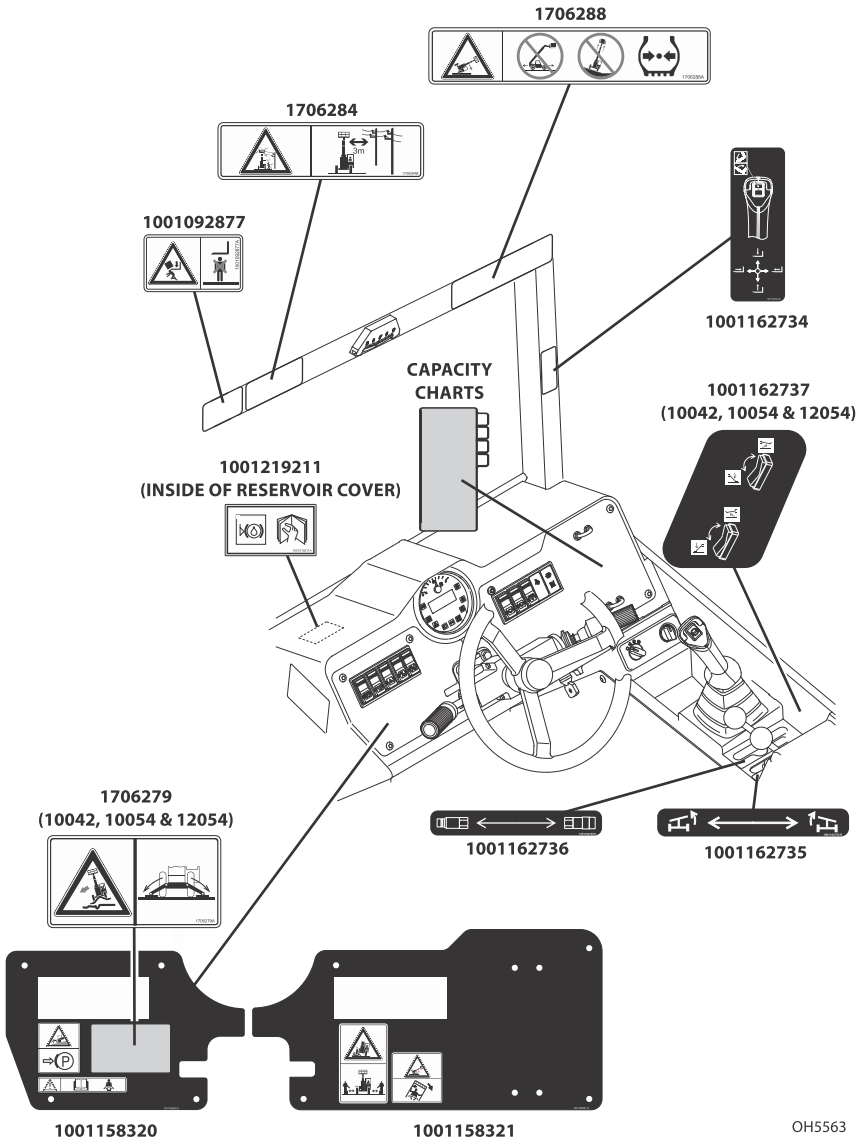

OH5563



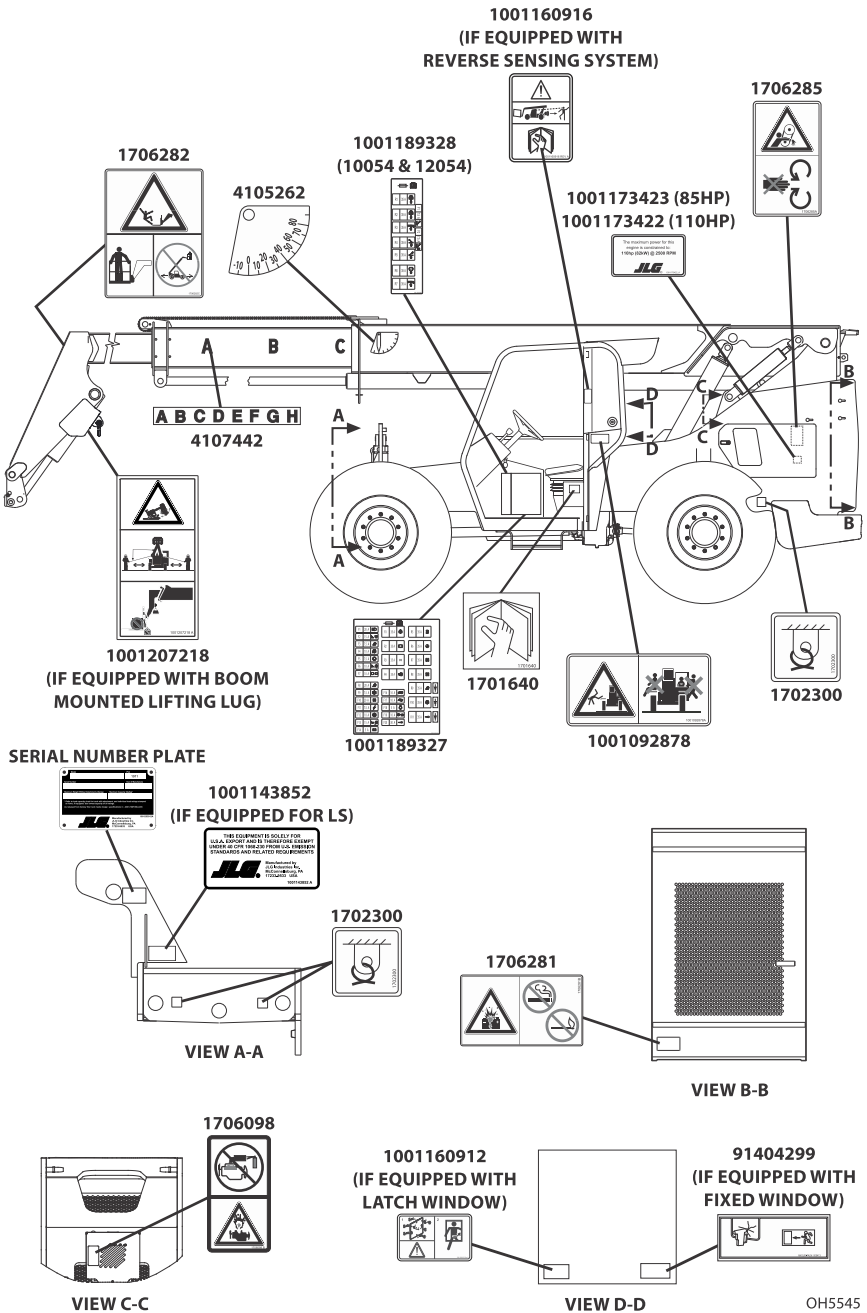

- 1001191992 (6036)
- 1001191993 (6042)
- 1001191994 (8042)
- 1001191995 (10042)
- 1001191996 (10054)
- 1001254736 (12054)

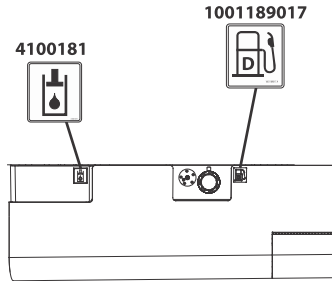
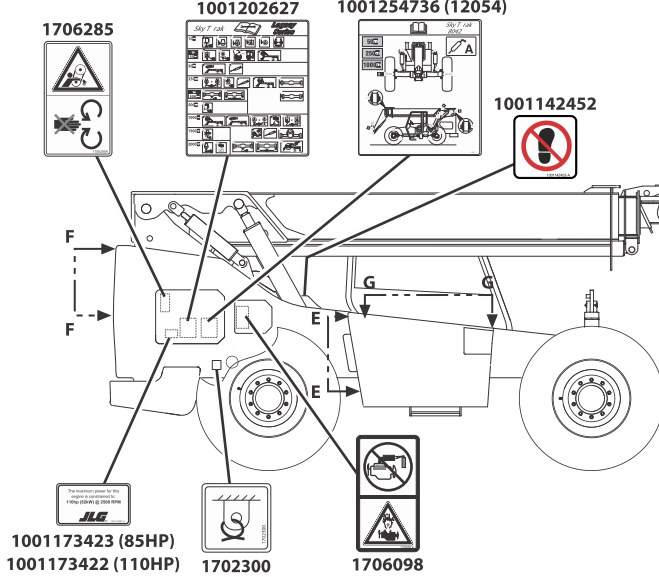

VIEW G-G

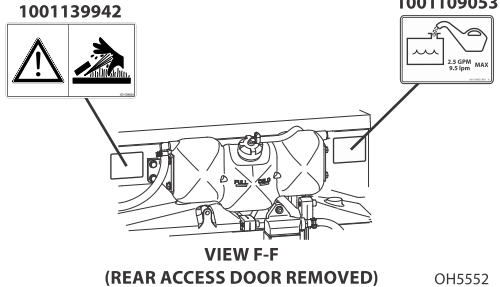
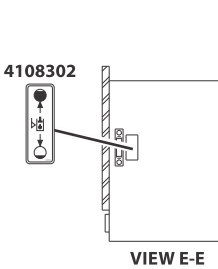

OH5552

## 2.4 WALK-AROUND INSPECTION

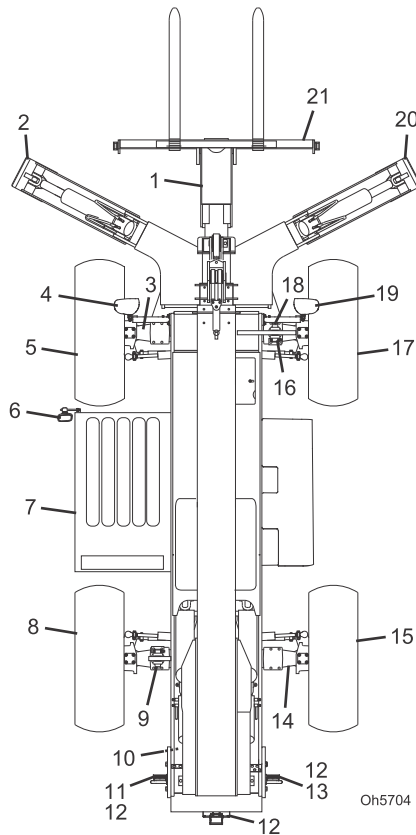

Begin your walk-around inspection at item 1, as noted below. Continue to your right (counterclockwise when viewed from top) checking each item in sequence.

**INSPECTION NOTE:** On all components, make sure there are no loose or missing parts, that they are securely fastened and no visible leaks or excessive wear exists in addition to any other criteria mentioned. Inspect all structural members including attachment for cracks, excessive corrosion and other damage.

1. **Boom Sections and Lift, Tilt, Extend/Retract, Compensating (Slave) Cylinders**
  - a. Check front, top, side and rear wear pads for presence of grease.
  - b. Pivot pins secure; hydraulic hoses undamaged, not leaking.
2. **Left Outrigger** — (10042, 10054 & 12054) Pins secure; hydraulic hoses and cylinder undamaged, not leaking.
3. **Front Axle** — Steer cylinders undamaged, not leaking; pivot pins secure; hydraulic hoses undamaged, not leaking.

4. **Front Lights (if equipped)** — Clean and undamaged.
5. **Wheel/Tire Assembly** — Properly inflated and secured; no loose or missing lug nuts. Inspect for worn tread, cuts, tears or other discrepancies.
6. **Mirrors** — Clean and undamaged.
7. **Cab and Electrical**
  - General appearance; no visible damage.
  - Frame level indicator and window glass undamaged and clean.
  - Gauges, switches, joysticks, foot controls and horn operational.
  - Emergency escape hammer in place (fixed window only).
  - Check seat belt for damage, replace belt if frayed or cut webbing, damaged buckles or loose mounting hardware.
8. **Wheel/Tire Assembly** — Properly inflated and secured; no loose or missing lug nuts. Inspect for worn tread, cuts, tears or other discrepancies.
9. **Stabil-Trak Cylinder** — Pins secure; hydraulic hoses undamaged, not leaking.
10. **Engine Compartment**
  - Drive belts, check condition and replace as required.
  - Engine mounts—See inspection note.
  - Battery cables tight, no visible damage or corrosion.
  - Engine access doors closed and properly secured.
  - Air Shutoff Valve (ASOV) (if equipped)—See inspection note.
11. **Rear Lights (if equipped)** — Clean and undamaged.
12. **Reversing Cameras (if equipped)** — See inspection note.
13. **Rear Lights (if equipped)** — Clean and undamaged.
14. **Rear Axle** — Steer cylinders undamaged, not leaking; pivot pins secure; hydraulic hoses undamaged, not leaking.
15. **Wheel/Tire Assembly** — Properly inflated and secured; no loose or missing lug nuts. Inspect for worn tread, cuts, tears or other discrepancies.
16. **Mirrors** — Clean and undamaged.
17. **Wheel/Tire Assembly** — Properly inflated and secured; no loose or missing lug nuts. Inspect for worn tread, cuts, tears or other discrepancies.
18. **Frame Level Cylinder** — Pins secure; hydraulic hoses undamaged, not leaking.
19. **Front Lights (if equipped)** — Clean and undamaged.

20. **Right Outrigger** (10042, 10054 & 12054) — Pins secure; hydraulic hoses and cylinder undamaged, not leaking.
21. **Attachment** — Properly installed, see “Attachment Installation” on page 5-16.

## 2.5 WARM-UP AND OPERATIONAL CHECKS

---

### 2.5.1 Warm-Up Check

During warm-up period, check:

1. Heater, defroster and windshield wiper (if equipped).
2. Check all lighting systems (if equipped) for proper operation.
3. Adjust mirror(s) for maximum visibility.

**Note:** **CUT/CRUSH/BURN HAZARD.** Keep engine cover closed while engine is running except when checking transmission oil level.

### 2.5.2 Operational Check

When engine warms, perform an operational check:

1. Service brake and parking brake operation.
2. Forward and reverse travel.
3. Each Gear.
4. Steering in both directions with engine at low idle (steering lock to lock will not be reached). Check in each steering mode.
5. Horn and back-up alarm. Must be audible from inside operators cab with engine running.
6. All joystick functions operate smoothly and correctly.
7. Perform any additional checks described in Section 8.

## 2.6 CAB

---

The telehandler is equipped with an open or enclosed ROPS/FOPS cab.

### **WARNING**

Never operate telehandler unless the overhead guard, cab structure and right side glass or screen are in good condition. Any modification to this machine must be approved by JLG to assure compliance with ROPS/FOPS certification for this cab/machine configuration. If the overhead guard or cab structure is damaged, the **CAB CANNOT BE REPAIRED**. It must be **REPLACED**.

### **WARNING**

Never drill, cut, and/or weld to cab. Any modification to this machine must be approved by JLG to assure compliance with machine configuration. If unauthorized drilling, cutting and/or welding is present, the cab must be **REPLACED**.

## 2.7 WINDOWS

---

Keep all windows and mirrors clean and unobstructed.

## 2.7.1 Cab Door Window (if equipped)

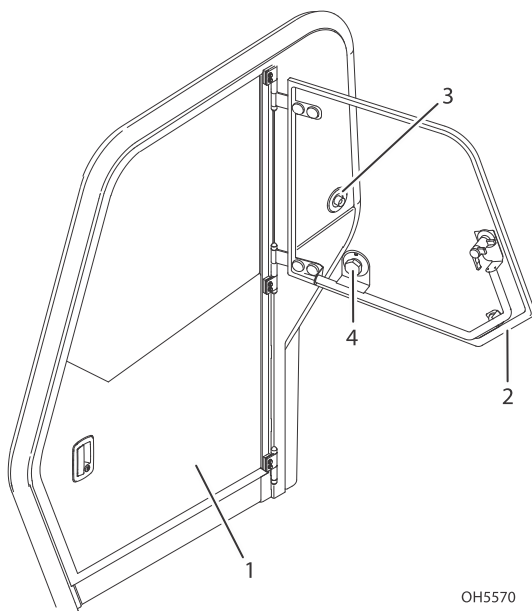

- Cab door window (2) must either be latched open or closed during operation.
- Open cab door window and secure it in latch (3).
- Turn knob (4) to unlatch window.

# NOTICE

**EQUIPMENT DAMAGE.** Cab door (1) must be closed during operation. Failure to do so may result in machine damage.

**This Page is intentionally left blank**



# SECTION 3

## Controls and Indicators

### 3.1 GENERAL

This section provides the necessary information needed to understand control functions.

### 3.2 CONTROLS

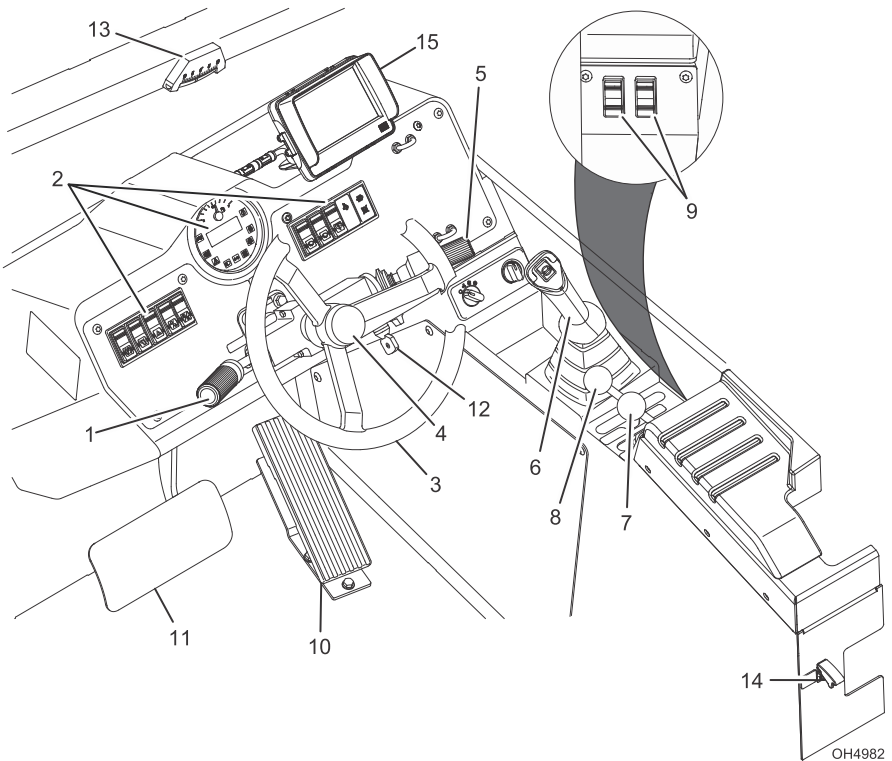

1. **Transmission Control Lever:**
2. **Dash Controls and Indicators:**
3. **Steering Wheel:** Turning the steering wheel to the left or right steers the machine in the corresponding direction. Three steering modes are available.
4. **Horn:** Press to sound horn.
5. **Accessory Control Lever (if equipped):**

6. **Boom Joystick:**
7. **Frame Level Joystick:**
8. **Auxiliary Hydraulic Joystick:**
9. **Outrigger Switches (10042, 10054 & 12054):**
10. **Accelerator Pedal:** Pressing down the pedal increases engine and hydraulic speed.
11. **Service Brake Pedal:** The further the pedal is depressed, the slower the travel speed. (6042, 8042, 10042, 10054 & 12054 Only) With service brake pedal depressed and boom angles above 40°, the locked mode of the Stabil-Trak system is activated.
12. **Ignition Switch:** Key activated.
13. **Frame Level Indicator:** Enables operator to determine the left to right level condition of the telehandler.
14. **Air Shutoff Valve (ASOV) Test Switch (if equipped):**
15. **Reversing Camera Monitor (if equipped):**

### 3.2.1 Dash Controls and Indicators

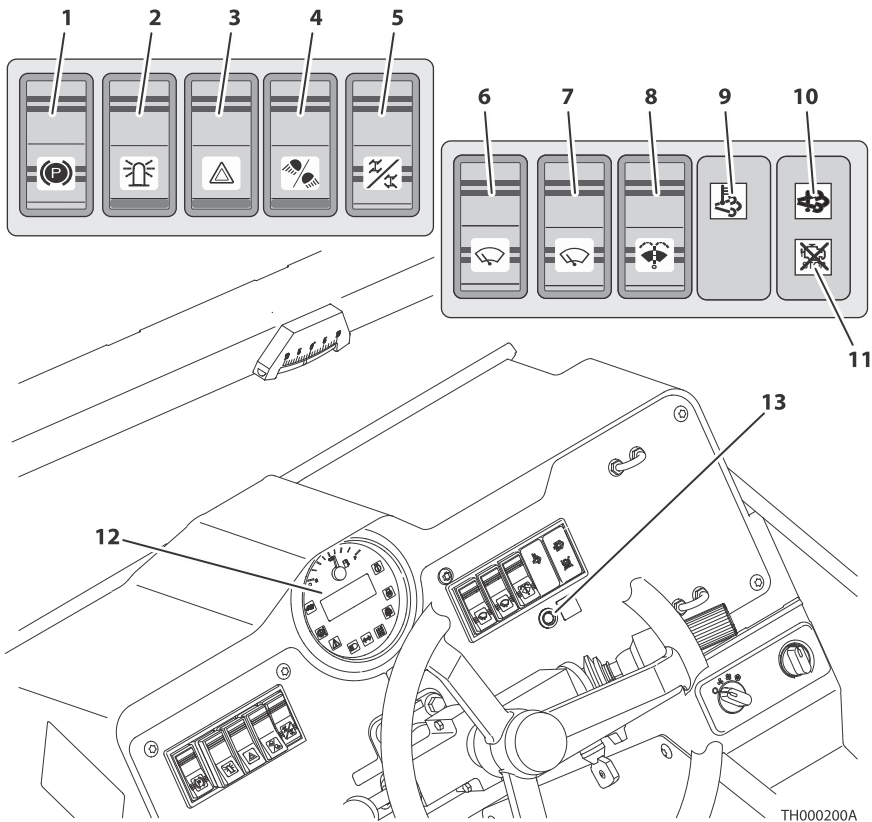

TH000200A

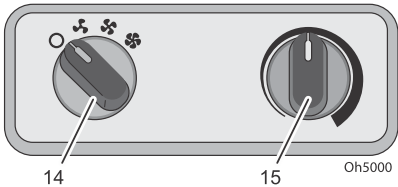

Figure 1. With Heater (If equipped)

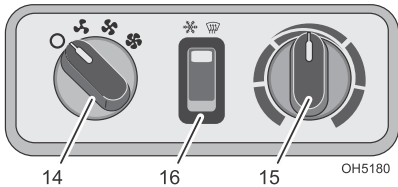
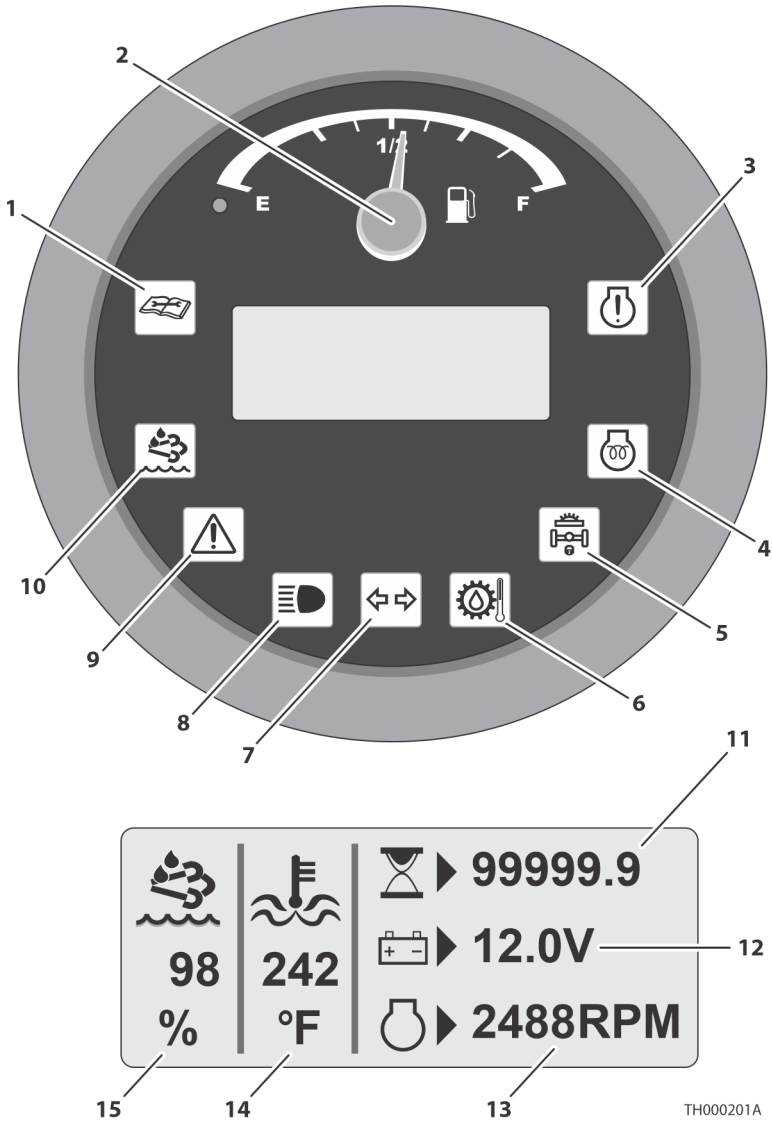

Figure 2. With Heater and AC (If equipped)

- 1. **Park Brake Switch:** On/Off switch.
- 2. **Beacon Light Switch (if equipped):** On/Off switch.
- 3. **Hazard Light Switch (if equipped):** On/Off switch.

4. **Work Light Switch (if equipped):** Three position switch. Push bottom of switch to turn all work lights on. Move switch to middle position to turn on front and boom work lights. Push top of switch to turn off all work lights.
5. **Steer Select Switch:** Three positions: 4-wheel circle steer, 4-wheel crab steer and 2-wheel front steer.
6. **Windshield Wiper Switch (if equipped):** Three position switch. Push bottom of switch to operate wiper at high speed. Move switch to middle position to operate wiper at low speed. Push top of switch to turn off wiper.
7. **Skylight Wiper Switch (if equipped):** Three position switch. Push bottom of switch to operate wiper at high speed. Move switch to middle position to operate wiper at low speed. Push top of switch to turn off wiper.
8. **Windshield and Skylight Washer Switch (if equipped):** Push and hold bottom of switch to activate washer.
9. **High Exhaust System Temperature Indicator (HEST) (if equipped for ULS/85 or 110HP):** May illuminate during exhaust system cleaning.
10. **Selective Catalytic Reduction (SCR) Indicator (if equipped for ULS/85 or 110HP):** Illuminates when stationary cleaning is required. Flashes during cleaning process.
11. **Do Not Turn Off Engine Indicator (if equipped for ULS/85 or 110HP):** Illuminates when stationary cleaning required.
12. **Instrument Cluster:** Instrument Cluster
13. **Air Shutoff Valve (ASOV) Indicator Lamp (if equipped):** Indicates when the ASOV valve has been actuated.  
**Heater and Air Conditioning Controls (If equipped)**
14. **HVAC Fan Speed (if equipped):** Adjustable rotary switch.
15. **HVAC Temperature Control Switch (if equipped):** Adjustable rotary switch.
16. **Air Conditioning (AC) Switch (if equipped):** Two-position switch.

### 3.2.2 Instrument Cluster



1. **Maintenance Indicator:** Flashes when fault code present. Illuminates when maintenance is required. See Service Manual for details.
2. **Fuel Gauge:** Indicates fuel level.
3. **Engine Warning Indicator:** Illuminates when the engine is in a critical state. Immediately bring machine to a stop, retract and lower boom and stop the engine. Determine cause and correct before continued use.

4. **Engine Pre-Heat Indicator:** Illuminates with ignition key in position 1. Indicator goes out when start temperature is reached. (If equipped for **ULS**) Pre-heat indicator will flash and fault code will appear on instrument cluster display during starter lockout. Return ignition switch to position 1 for a minimum of two minutes to allow system to reset before trying to start again.
5. **Stabil-Trak Indicator (6042, 8042, 10042, 10054 & 12054):** Illuminates when Stabil-Trak system has been activated.
6. **Transmission Temperature Indicator:** Illuminates when transmission oil temperature is high. Stop and idle engine with transmission in neutral, allowing time for cooling. If light remains on, shut-down engine.
7. **Turn Signal Indicator (if equipped):** Illuminates and flashes while turn signals or hazard lights are activated.
8. **High Beam Indicator (if equipped):** Illuminates while high beam lights are activated.
9. **System Distress Indicator:** Illuminates when an issue with the fuel level or machine system is present.
10. **Diesel Exhaust Fluid (DEF) Low Indicator (if equipped for ULS/85 or 110HP):** Illuminates when DEF volume is low. Also may illuminate if DEF quality is poor or if DEF system tampering or malfunction occurs. If DEF tank assembly is still under warranty, contact Cummins prior to servicing.
11. **Operating Hours and Fault Codes:**
  1. *Operating Hours*—Displays total hours of telehandler operation.
  2. *Fault Codes*—Replaces operating hours. Displays fault codes of engine and machine systems. See *Service & Maintenance manual*.
12. **Battery Voltage and Operating Hours:**
  1. *Battery Voltage*—Displays voltage supplied by battery.
  2. *Operating Hours*—Alternates with battery voltage if fault code present.
13. **Engine Speed:** Displays engine speed in revolutions per minute (rpm).
14. **Engine Coolant Temperature:** Displays engine coolant temperature.
15. **Diesel Exhaust Fluid (DEF) Level (if equipped for ULS/85 or 110HP):** Displays fluid level.

### 3.2.3 Ignition

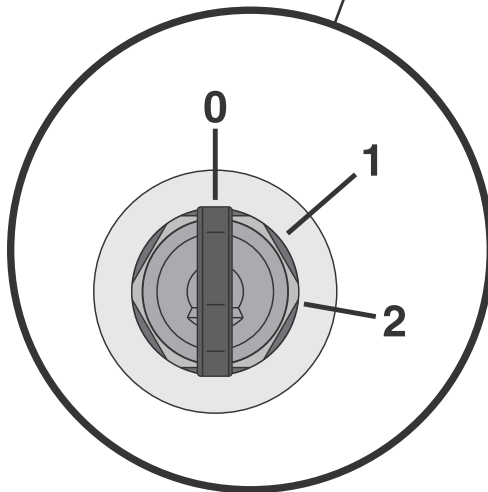
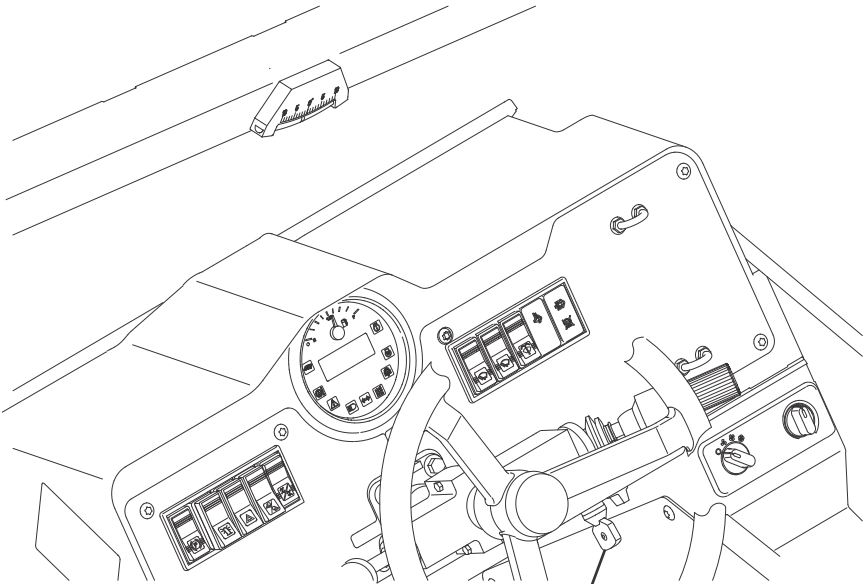

TH000202A

- Position **0**: Engine off, no voltage available.
- Position **1**: Voltage available for all electrical functions. Wait to start engine until engine pre-heat indicator goes out.
- Position **2**: Engine run.

- Position 2: Engine start. In event engine does not start, rotate key to position 0 then back to position 2 to re-engage starter.

### 3.2.4 Park Brake

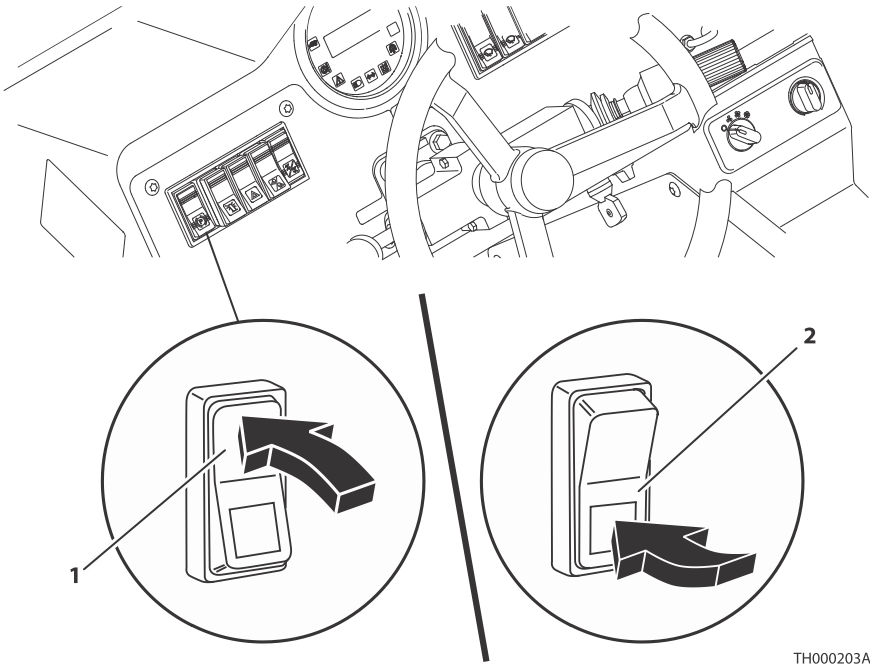

TH000203A

Park brake switch controls application and release of park brake. Indicator on switch illuminates to indicate brake is applied.

- With engine running and the park brake switch in "OFF" position (1), park brakes are disengaged.
- With switch in "ON" position (2), park brake is engaged and transmission will not engage forward or reverse.



- (6042, 8042, 10042, 10054 & 12054 Only) With switch in "ON" position and boom angles greater than 40°, locked mode of Stabil-Trak system is activated.

## ⚠ WARNING

**MACHINE ROLL-AWAY HAZARD.** In the event of engine failure, apply constant pressure to service brake pedal while activating the park brake to the ON position.

## ⚠ WARNING

**MACHINE ROLL-AWAY HAZARD.** Always move park brake switch to ON position, lower boom to ground and stop engine before leaving cab.

## ⚠ WARNING

**CRUSH HAZARD.** Turning engine off applies the park brake. Applying park brake or turning engine off while traveling will cause unit to stop abruptly and could cause load loss. Either may be used in an emergency situation.

### 3.2.5 Parking Procedure

1. Using service brake, stop telehandler in an appropriate parking area.
2. Follow "Shut-Down Procedure".

### 3.2.6 Transmission Control Lever

#### Direction of Travel Selection

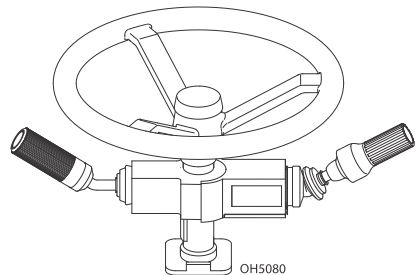
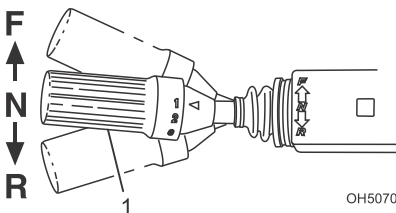

Transmission control lever (1) engages forward or reverse travel.

- Lift and push lever forward for forward travel; lift and pull lever rearward for reverse travel. Move lever to centered position for neutral.
- Forward or reverse travel can be selected while in any gear.

- When traveling in reverse, back-up alarm will automatically sound.
- Drive in reverse and turn only at slow rates of speed.
- Do not increase engine speed with transmission in forward or reverse and service brake depressed in an attempt to get quicker hydraulic performances. This could cause unexpected machine movement.
- (6042, 8042, 10042, 10054 & 12054 Only) With lever in neutral and boom angles greater than 40°, locked mode of Stabil-Trak system is activated.

# ! WARNING

**TIP OVER/CRUSH HAZARD.** Bring telehandler to a complete stop before shifting transmission control lever. A sudden change in direction of travel could reduce stability and/or cause load to shift or fall.

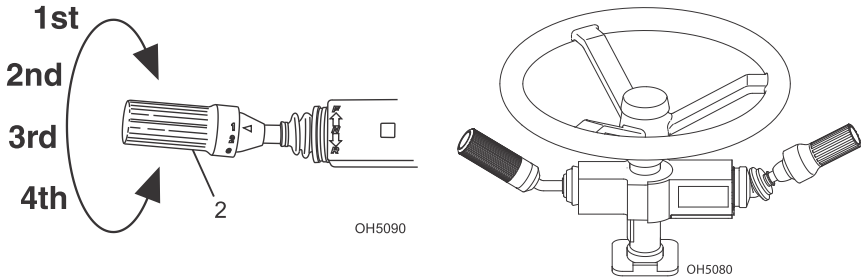

Gear selection is located on the twist grip handle (2) of transmission control lever.

- Twist hand grip to select gear.
- Select appropriate gear for task being performed. **Use a lower gear when transporting a load.** Use a higher gear only when driving unloaded for longer distances.
- Slow down prior to downshifting. **Do not downshift more than one gear at a time.**

### 3.2.7 Boom Joystick

# ! WARNING

**TIP OVER/CRUSH HAZARD.** Rapid, jerky operation of controls will cause rapid, jerky movement of the load. Such movements could cause the load to shift or fall or could cause the machine to tip over.

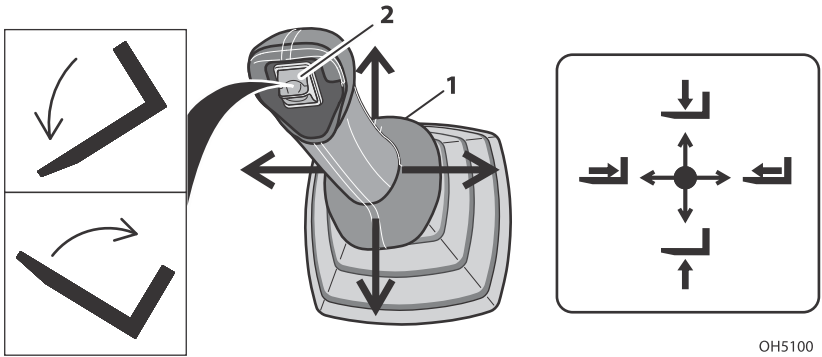

OH5100

Boom Joystick (1) controls boom and attachment tilt functions.

### Boom Functions

- Move joystick back to lift boom; move joystick forward to lower boom; move joystick right to extend boom; move joystick left to retract boom.
- Speed of boom functions depends upon amount of joystick travel in corresponding direction. Increasing engine speed will also increase function speed.
- For two simultaneous boom functions, move joystick between quadrants. Example: moving joystick forward and to left will lower and retract boom simultaneously.

### Attachment Tilt Functions

Attachment tilt is controlled by roller switch (2).

- Push roller switch up to tilt attachment down; push roller switch down to tilt attachment up.

### 3.2.8 Auxiliary Hydraulic Joystick

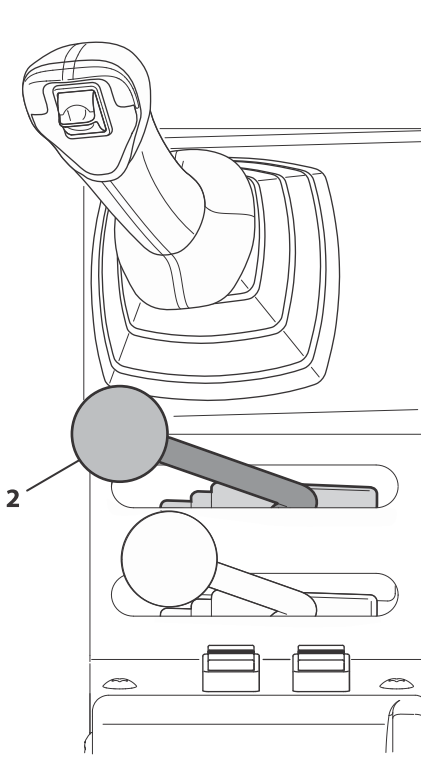

OH5120

Auxiliary hydraulic joystick (2) controls function of attachments that require hydraulic supply for operation. See Section 5- Attachments for approved attachments and control instructions.

### 3.2.9 Frame Level Joystick

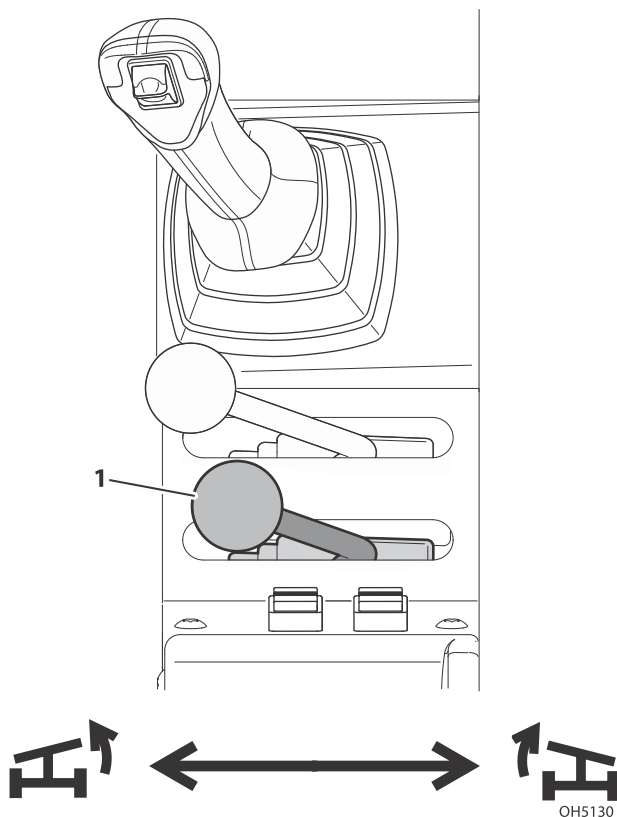

Frame level joystick (1) controls left to right frame level.

- Move joystick left to rotate frame left, move joystick right to rotate frame right.
- A level indicator is located above front cab window to permit operator to determine whether telehandler frame is level.

## ⚠ WARNING

**TIP OVER HAZARD.** Always move boom as low as possible while allowing for best visibility of right hand mirror before leveling frame. Attempting to level machine with boom raised could cause it to tip over.

### 3.2.10 Outrigger Switches (10042, 10054 & 12054)



Outrigger switches control outriggers.

- Left switch controls left outrigger and right switch controls right outrigger.
- Push bottom of switches (1) to lower outriggers; push top of switches (2) to raise outriggers.
- Use the outriggers to increase stability and/or load capacity and in leveling telehandler. Study capacity charts to determine maximum load capacities, with and without outriggers.

## **⚠ WARNING**

**TIP OVER HAZARD.** Outriggers increase stability and load capacity only if they are used properly. Using outriggers on soft surfaces could cause telehandler to tip over. Always ensure surface can support telehandler and load.

### 3.2.11 Accessory Control Lever (if equipped)

Accessory control lever (3) operates turn signals, parking lights and headlights.

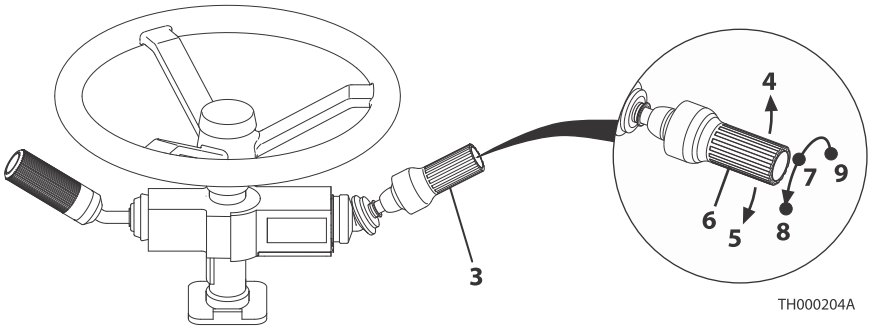

TH000204A

### Turn Signal

- Raise lever (4) to activate left turn signal.
- Lower lever (5) to activate right turn signal.
- Lever must be manually returned to center position to deactivate either turn signal. Lever will not cancel automatically after a turn.

### Parking Lights and Headlights

- Turn twist grip (6) of lever counterclockwise to first position (7) to turn on parking lights.
- Turn twist grip to second position (8) to turn on headlights.
- Pull lever to switch between low and high beam.
- Turn twist grip clockwise to OFF position (9) to turn all lights off.

## 3.3 STEER MODES

Three steer modes are available for operator use.

2-  
Wheel  
Front  
Steer

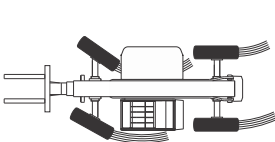

OAL2030

4-Wheel Circle  
Steer

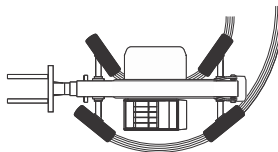

4-Wheel  
Crab Steer

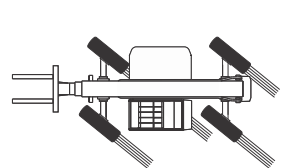

**Note:** 2-Wheel Front Steer mode is required for travel on public roads.

### 3.3.1 Steer Mode Change

**Note:** Steer mode will change immediately after selection.

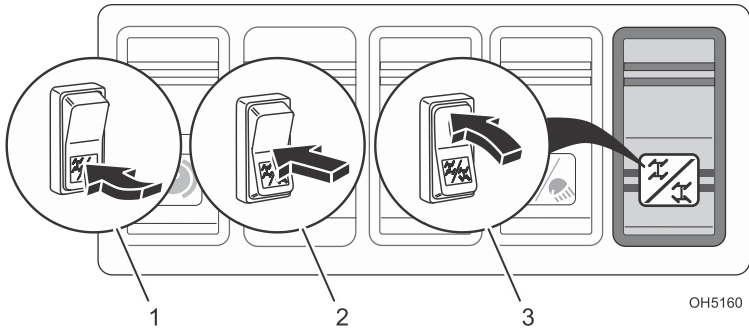

1. Bring machine to a stop using service brake while either circle steer mode (1) or crab steer mode (3) is selected.

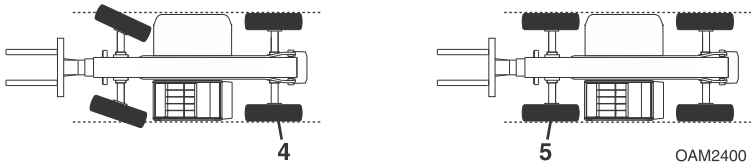

2. Turn steering wheel until left rear wheel (4) is aligned with side of machine.
3. Select front steer mode (2).
4. Turn steering wheel until left front wheel (5) is aligned with side of machine.
5. Wheels are now aligned. Select desired steer mode.



### 3.4 STABIL-TRAK™ SYSTEM (6042, 8042, 10042, 10054 & 12054)

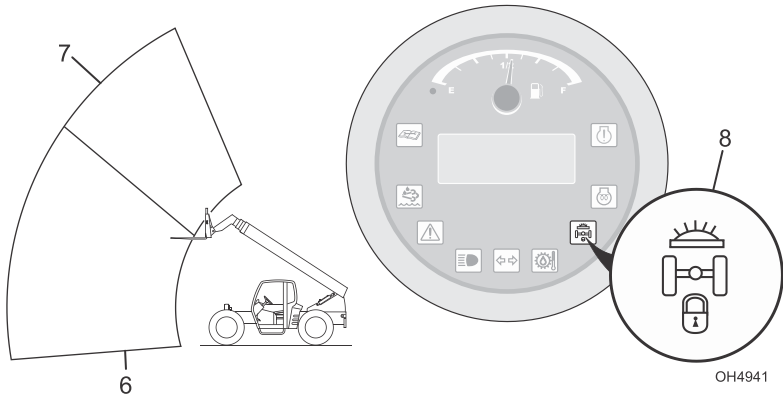

#### 3.4.1 Free Pivot Mode

With boom below 40° (6), Stabil-Trak system is in Free Pivot Mode. Rear axle pivots freely and frame level functions normally. Stabil-Trak indicator (8) will be off.

#### 3.4.2 Slow Pivot Mode

With boom above 40° (7), the Stabil-Trak system is in Slow Pivot Mode when service brake is not applied and transmission is in gear. Rear axle will respond slowly to changes in terrain and frame level functions normally. Stabil-Trak indicator (8) will be off.

#### 3.4.3 Locked Mode

With boom above 40° (7), and activating one or more of following functions, Stabil-Trak system is in Locked Mode.

- Park brake switch engaged.
- Transmission control lever in Neutral.
- Service brake pedal depressed.

Rear axle is locked and frame level functions slower than normal. Stabil-Trak indicator (8) will illuminate.

### 3.5 BOOM/OUTRIGGER INTERLOCK SYSTEM (10054 & 12054)

Boom/outrigger interlock system allows boom to be extended to its maximum limits.

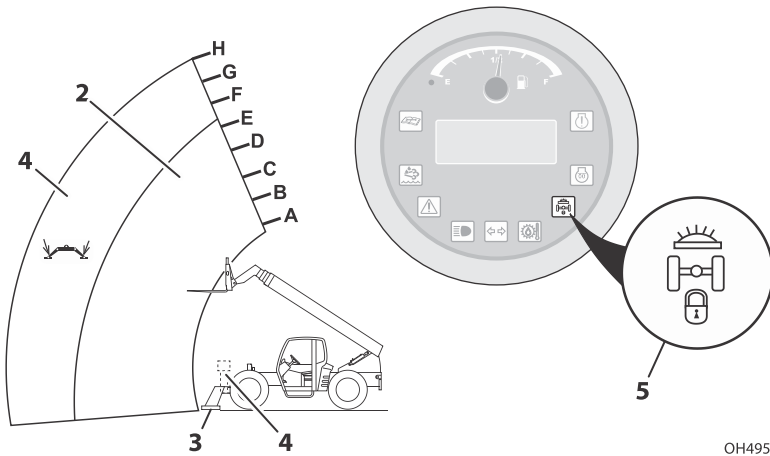

OH4951

### 3.5.1 Extend Interlock Mode

With outriggers raised (1), telehandler is in extend interlock mode which limits boom extension (2).

- Boom is limited from extending beyond a point between the “E” and “F” boom extension indicators.
- Vehicle and Stabil-Trak will function normally.

### 3.5.2 Outrigger Interlock Mode

With outriggers lowered (3) on firm terrain, telehandler is in outrigger interlock mode which allows for full boom extension (4).

When outriggers are lowered, shift travel select lever into neutral and engage parking brake.

With outrigger interlock engaged, additional systems are automatically activated.

- Stabil-Trak is in locked mode and indicator (5) will illuminate.
- Frame level will be slower than normal.
- Outriggers can be lowered to adjust for any changes in outrigger footing.

Boom must be retracted within extension limit (2) for any of these conditions to change.

## 3.6 OPERATOR SEAT

---

### 3.6.1 Adjustments

Prior to starting engine adjust seat for position and comfort.

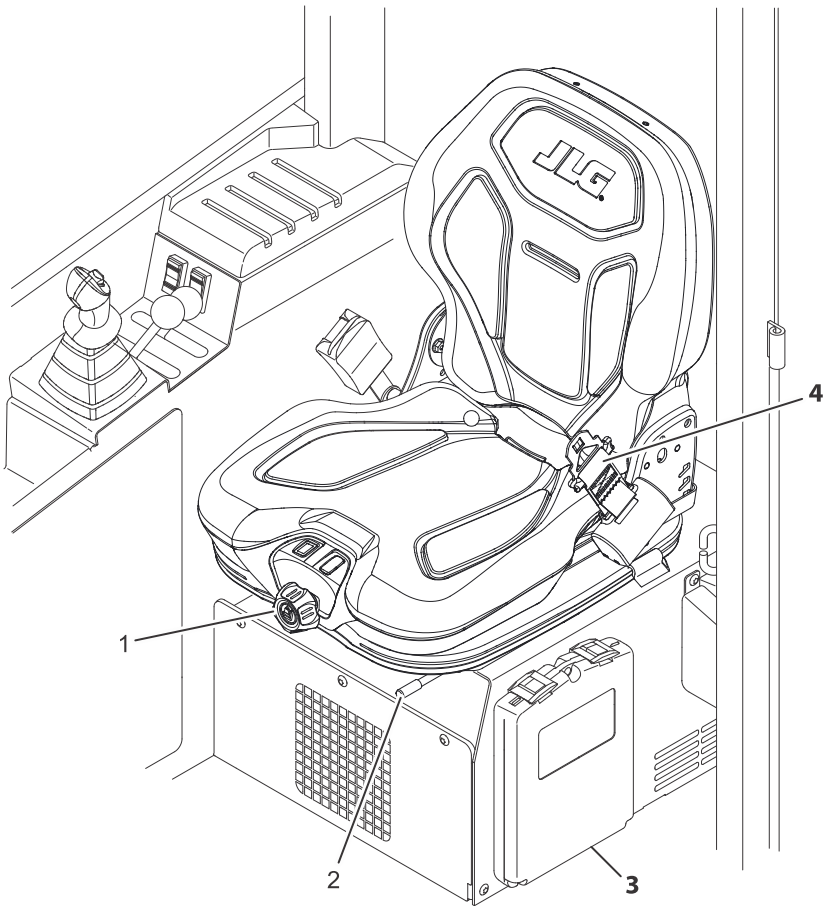

Oh5790

1. **Suspension:** Use knob to adjust suspension to the appropriate setting. Turn clockwise to increase stiffness. Turn counterclockwise to reduce stiffness.
2. **Fore/Aft:** Pull up on handle to move seat fore and aft.
3. **Document Case:** Contains unit materials.
4. **Seat Belt:** Always fasten seat belt during operation. If required, a 3 in (76 mm) seat belt is available.

### 3.6.2 Seat Belt

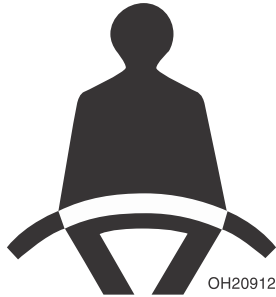

Fasten seat belt as follows:

1. Grasp both free ends of the belt making certain that belt webbing is not twisted or entangled.
2. With back straight in seat, couple retractable end (male end) of belt into receptacle (buckle) end of belt.
3. With belt buckle positioned as low on body as possible, pull retractable end of belt away from buckle until it is tight across lap.
4. To release belt latch, depress red button on buckle and pull free end from buckle.

### 3.7 BOOM ANGLE AND EXTENSION INDICATORS

---

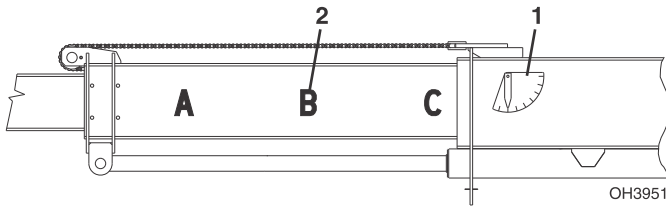

- Boom angle indicator (1) is located on left side of boom. Use this indicator to determine boom angle when using capacity chart.
- Boom extension indicators (2) are located on left side of boom. Use these indicators to determine boom extension when using capacity chart.

### 3.8 REVERSE SYSTEMS (IF EQUIPPED)

---

## **⚠ WARNING**

**CRUSH HAZARD.** Running into persons or objects can cause death, serious injury, or damage to property and equipment. Always check mirrors and area behind machine before and when backing up. Reverse systems are for supplementary use only.

### 3.8.1 Reverse Sensing System

The reverse sensing system provides audible indication of objects to rear of machine while in reverse gear.

- Alarm sounds when transmission is shifted into reverse.

**Note:** Reverse Sensing System detects objects larger than 36 square inches (232.25 square centimeters) area and is functional when machine is moving in reverse direction.

- No alarm when detection zone is clear of objects.
- Pulsing alarm sounds when an object is in range of Reverse Sensing System. Alarm increases in frequency as object becomes closer.
- If alarm sounds at a frequency of eight pulses per second (8 Hz) an object is detected within 5 feet (1.5 m). Stop reverse direction of machine by applying service brake. Perform "Shut-Down Procedure" on page 4-5. Check and clear area behind machine of objects before proceeding in a reverse direction.

### 3.8.2 Multi View Camera

The multi view camera provides additional views of the area directly behind, to the left, and to the right of the telehandler. The view displays on the multi view camera monitor when the key is switched on and transmission is in reverse.



The screen provides a graphic overlay indicating approximate distances of objects around the rear of the telehandler.

## NOTICE

**EQUIPMENT MALFUNCTION.** Always keep camera lens clean. Camera may not operate normally at extremely high or low temperatures.

**This Page is intentionally left blank**

# SECTION 4

## Operation

---

### 4.1 ENGINE

---

#### 4.1.1 Starting the Engine

This machine can be operated under normal conditions in temperatures of 0°F to 104°F (-20° C to 40° C). Consult JLG for operation outside this range or under abnormal conditions.

If equipped for extreme cold weather, -20°F to 0°F (-29°C to -18°C), see page 4-3 for starting procedure.

1. Make sure all controls are in "Neutral" and all electrical components (lights, heater, etc.) are turned off. Apply park brake.
2. Turn ignition switch to position 1 and wait for engine pre-heat indicator on instrument cluster to go out.
3. Turn ignition switch to position 2 to engage starting motor. Release key immediately when engine starts. If engine fails to start within 20 seconds, release key and allow starting motor to cool for two minutes before trying again.

**Note:** (If equipped for ULS) Engine is equipped with starter lockout feature and may prevent starter engagement under certain conditions. Pre-heat indicator will flash and fault code will appear on instrument cluster display. Return ignition switch to position 1 for a minimum of two minutes to allow system to reset before trying to start again.

4. After engine starts, observe instrument cluster. If indicators remain on for more than five seconds, stop engine and determine cause before restarting engine.

**Note:** Battery voltage may read low, and engine speed may fluctuate for a short time after start up when the machine is cold.

5. Warm up engine at approximately 1/2 throttle.  
**If starting from 0°F to 15°F (-18°C to -9°C)**
6. Allow engine to idle 20 minutes.

## Operation

---

7. Operate all boom functions continuously for five minutes to circulate the warm hydraulic fluid.

**Note:** Engine will not start unless transmission is in neutral and park brake is applied.

### **WARNING**

**ENGINE EXPLOSION.** Do not use ether for cold weather starting.

### **WARNING**

**UNEXPECTED MOVEMENT HAZARD.** Always ensure that transmission is in neutral and the service brake is applied before releasing park brake. Releasing park brake in either forward or reverse could cause the machine to move abruptly.

#### 4.1.2 Extreme Cold Weather Starting (if equipped)

If equipped with extreme cold weather components, machine can be operated in temperatures of -20°F to 0°F (-29° C to -18° C).

1. Machine must be equipped with heating components and extreme cold weather fluids. See Section 9- Specifications for fluid details.
2. Locate the two yellow extension cords stored behind seat in cab.
3. Connect the hydraulic tank heater to one extension cord and the battery and block heaters to the other extension cord. Connect each extension cord to separate A/C power supplies with a minimum rating of 15 Amps each.
4. Allow the heating components to operate a minimum of 12 hours prior to machine operation.
5. Follow start-up procedure on page 4-1 and allow engine to idle 20 minutes.
6. Operate all boom functions continuously for five minutes to circulate the warm hydraulic fluid.
7. Perform "Shut-Down Procedure" on page 4-5.
8. Disconnect A/C power supplies and place back in storage locations.
9. Machine is ready for operation.



### 4.1.3 Battery Boosted Starting



OW0530

If battery-boost starting (jump-start) is necessary, proceed as follows:

- Never allow vehicles to touch.
- Ensure boosting vehicle engine is running.
- Connect positive (+) jumper cable to positive (+) post of discharged battery.
- Connect opposite end of positive (+) jumper cable to positive (+) post of booster battery.
- Connect the negative (-) jumper cable to negative (-) post on booster battery.
- Connect opposite end of negative (-) jumper cable to ground point on machine away from discharged battery.
- Follow standard starting procedures.
- Remove cables in reverse order after machine has started.

## ⚠ WARNING

**BATTERY EXPLOSION HAZARD.** Never jump start or charge a frozen battery as it could explode. Keep sparks, flames and lighted smoking materials away from the battery. Lead acid batteries generate explosive gases when charging. Wear safety glasses.

### 4.1.4 Normal Engine Operation

- Observe gauges and indicators frequently to be sure all systems are functioning properly.
- **Be alert for unusual noises or vibration.** When an unusual condition is noticed, park machine in safe position and perform shut-down procedure. Report condition to your supervisor or maintenance personnel.
- **Avoid prolonged idling.** If engine is not being used, turn it off.
- If prolonged idling is required (park brake applied), engine idle may increase if ambient temperature goes below -1°F (-17°C).

## Operation

---

- When operating a machine at high altitudes, a decrease in machine performance may occur due to a decrease in air density. When operating a machine at high temperatures, a decrease in machine performance and an increase in engine coolant temperature may occur. Contact JLG for operation under abnormal conditions.

### 4.1.5 Shut-Down Procedure

When parking the telehandler, park in a safe location on flat level ground and away from other equipment and/or traffic lanes.

1. Apply the park brake.
2. Shift the transmission to "Neutral."
3. Lower forks or attachment to the ground.
4. Operate engine at low idle for 3 to 5 minutes. **DO NOT over rev engine.**
5. Shut off engine and remove ignition key.
6. Exit telehandler properly.
7. Block wheels (if necessary).

### 4.2 AFTER-TREATMENT SYSTEM (ATS) (IF EQUIPPED FOR ULS/85 OR 110HP)

---

This machine is equipped with an exhaust After-Treatment System.

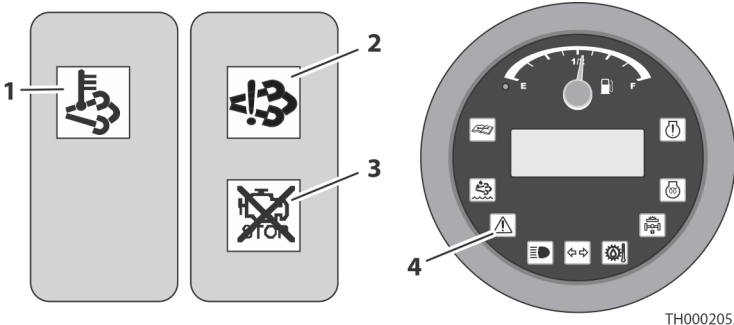

## 4.2.1 Automatic Exhaust System Cleaning

ATS is an automatic exhaust cleaning system and will perform as required without any operator interaction.

- High Exhaust System Temperature (HEST) (1) Indicator may illuminate during exhaust system cleaning.

### **WARNING**

**HIGH EXHAUST TEMPERATURE.** Keep flammables and people away from hot exhaust.

## 4.2.2 Stationary Exhaust System Cleaning

Selective Catalytic Reduction (SCR) Indicator (2) will illuminate when stationary exhaust system cleaning is required.

1. Move telehandler to an area free of flammables and people that could be exposed to hot exhaust.
2. Shift transmission to neutral, retract and lower boom and engage park brake.
3. When exhaust system cleaning begins, the HEST (1) and Do Not Turn Off Engine (3) indicators will illuminate. Do not turn off engine.
4. Do not press accelerator pedal or other controls during exhaust system cleaning.
5. SCR indicator (2) flashes during cleaning. Stationary exhaust system cleaning takes approximately 30 to 60 minutes.

**Note:** Stationary exhaust system cleaning will stop and may be incomplete if any controls are inadvertently moved or activated. If stationary exhaust cleaning is interrupted, HEST (1) and Do Not Turn Off Engine (3) indicators will turn off and SCR Indicator (2) will stop blinking and illuminate solid. To restart stationary exhaust system cleaning, depress service brake and disengage park brake. Return to step 1 and repeat process.

6. Stationary exhaust system cleaning is complete after HEST, SCR and Do Not Turn Off Engine indicators go off.

### **NOTICE**

**EQUIPMENT DAMAGE.** If exhaust system cleaning continually fails, SCR (2) and System Distress (4) indicators will illuminate. Immediately bring machine to a stop and perform stationary exhaust system cleaning. If exhaust system cleaning is not completed a torque derate is initiated. Contact the local dealer.

## 4.3 OPERATING WITH A NON-SUSPENDED LOAD

### 4.3.1 Lift Load Safely

- You must know weight and load center of every load you lift. If you are not sure of weight and load center, check with your supervisor or with supplier of the material.

## **⚠ WARNING**

**TIP OVER HAZARD.** Exceeding lift capacity of the telehandler could damage the equipment and/or cause tip over.

- Know rated load capacities (refer to [Section — Attachments](#)) of telehandler to determine operating range in which you can safely lift, transport and place a load.

### 4.3.2 Picking Up a Load

- Note conditions of the terrain. Adjust travel speed and reduce amount of load if conditions warrant.
- Avoid lifting double-tiered loads.
- Make sure load is clear of any adjacent obstacles.
- Adjust spacing of forks so they engage the pallet or load at maximum width. See [Section — Adjusting/Moving Forks](#).
- Approach load slowly and squarely with fork tips straight and level. **NEVER** attempt to lift a load with just one fork.
- **NEVER** operate telehandler without a proper and legible capacity chart in operator cab for telehandler/attachment combination you are using.

### 4.3.3 Transporting a Load



- After engaging the load and resting it against the backrest, tilt the load back to position it for travel. Travel in accordance with the requirements set forth in [Section — General Safety Practices](#) and [Section — Attachments](#).

### 4.3.4 Leveling Procedure

1. Position machine in best location to lift or place load.
2. Apply parking brake and shift transmission to NEUTRAL.
3. Observe level indicator to determine whether machine must be leveled prior to lifting load. Level machine with frame level joystick (see page 3-13) or outrigger switches (10042, 10054 & 12054 only, see page 3-14).

4. Move boom/attachment to 4 ft (1,2 m) off ground.  
(AUS - Move boom so forks are no more than 11.8 in (300 mm) above ground surface.)

### Important things to remember:

- Never raise boom/attachment more than 4 ft (1,2 m) above ground unless telehandler is level.  
(AUS - Never raise the forks more than 300 mm (11.8 in) above ground surface unless telehandler is level.)
- Combination of frame leveling and load could cause telehandler to tip over.

### 4.3.5 Placing a Load

Before placing any load be sure that:

- Landing point can safely support weight of the load.
- Landing point is level; front to back and side to side.
- Use capacity chart to determine safe boom extension range. See [Section — Use of the Capacity Chart](#).
- Align forks at level the load is to be placed, then position boom slowly until load is just above area where it is to be placed.
- Lower the boom until the load rests in position and the forks are free to retract.

### 4.3.6 Disengaging a Load

Once the load has been placed safely at the landing point, proceed as follows:

1. With forks free from weight of load, boom can be retracted.
2. Lower carriage.
3. Telehandler can now be driven from landing location to continue work.

## 4.4 OPERATING WITH A SUSPENDED LOAD

### 4.4.1 Lift Load Safely

- You must know weight and load center of every load you lift. If you are not sure of weight and load center, check with your supervisor or with supplier of the material.

## WARNING

**TIP OVER HAZARD.** Exceeding lift capacity of the telehandler could damage the equipment and/or cause tip over.

- Know rated load capacities (refer to [Section — Attachments](#)) of telehandler to determine operating range in which you can safely lift, transport and place a load.

### 4.4.2 Picking Up a Suspended Load

- Note conditions of terrain. Adjust travel speed and reduce amount of load if conditions warrant.
- Avoid lifting double-tiered loads.
- Make sure load is clear of any adjacent obstacles.
- **NEVER** operate telehandler without a proper and legible capacity chart in operator cab for telehandler/attachment combination you are using.
- Only use approved lifting devices rated for lifting of load.
- Identify proper lifting points of load, taking into consideration center of gravity and load stability.
- Ensure to always properly tether loads to restrict movement.
- Refer to [Section — Use of the Capacity Chart](#) for proper lifting guidelines in addition to appropriate capacity chart in operator cab.

### 4.4.3 Transporting a Suspended Load

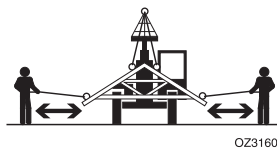

- Travel in accordance with the requirements set forth in [Section — General Safety Practices](#) and [Section — Attachments](#).
- For additional requirements, refer to appropriate capacity chart in operator cab.

#### Important things to remember:

- Ensure boom is fully retracted.
- Never raise load more than 11.8 in (300 mm) above ground surface or boom more than 45°.
- Combination of frame leveling and load could cause telehandler to tip over.
- Guide persons and operator must remain in constant communication (verbal or hand) and be in visual contact with operator at all times.
- Never place guide persons between suspended load and telehandler.
- Only transport load at walking speed, 0.9 mph (0.4 m/s), or less.

### 4.4.4 Leveling Procedure

1. Position machine in best location to lift or place load.
2. Apply parking brake and shift transmission to NEUTRAL.
3. Observe level indicator to determine whether machine must be leveled prior to lifting load. Level machine with frame level joystick (see page 3-13) or outrigger switches (10042, 10054 & 12054 only, see page 3-14).
4. Move boom so load is no more than 11.8 in (300 mm) above ground surface and boom/or boom is raised no more than 45°.

### 4.4.5 Placing a Suspended Load

Before placing any load be sure that:

- Landing point can safely support weight of load.
- Landing point is level; front to back and side to side.
- Use capacity chart to determine safe boom extension range. See [Section — Use of the Capacity Chart](#).
- Align load at level the load is to be placed, then position boom slowly until load is just above area where it is to be placed.
- Ensure that guide persons and operator remain in constant communication (verbal or hand) when placing load.

### 4.4.6 Disengaging a Suspended Load

- Never place guide persons between suspended load and telehandler.
- Once at destination of load, ensure to bring telehandler to a complete stop and apply park brake prior to disengagement of lifting devices and tethers.

## 4.5 LOADING AND SECURING FOR TRANSPORT

---

### 4.5.1 Tie Down

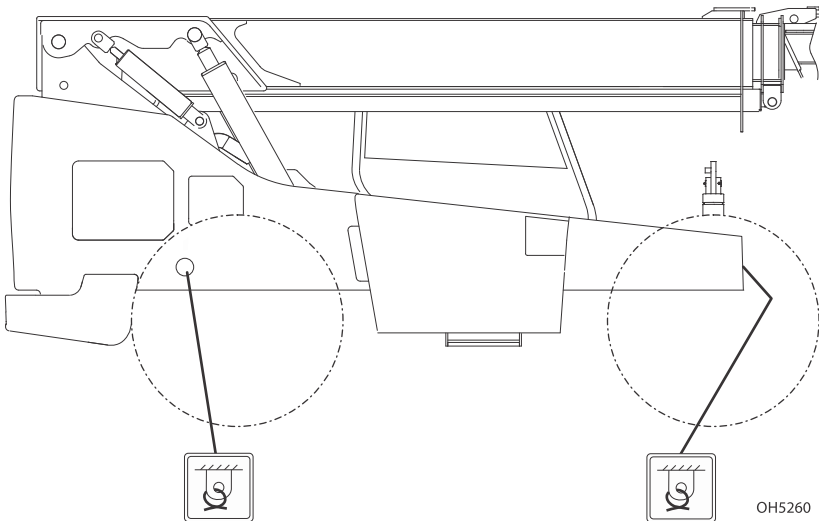

1. Level telehandler prior to loading.
2. Using a spotter, load telehandler with boom as low as possible.



3. Once loaded, apply parking brake and lower boom until boom or attachment is resting on deck. Move all controls to "Neutral," stop engine and remove ignition key.
4. Secure machine to deck by passing chains through designated tie down points as shown in figure.
5. Do not tiedown front of boom.

**Note:** User assumes all responsibility for choosing proper method of transportation and tiedown devices, making sure equipment used is capable of supporting weight of vehicle being transported and that all manufacturer's instructions and warnings, regulations and safety rules of their employer, Department of Transportation and/or any other local, state or federal/ provincial laws are followed.

## ⚠ WARNING

**TELEHANDLER SLIDE HAZARD.** Before loading telehandler for transport, make sure deck, ramps and telehandler wheels are free of mud, snow and ice. Failure to do so could cause telehandler to slide.

### 4.5.2 Lifting

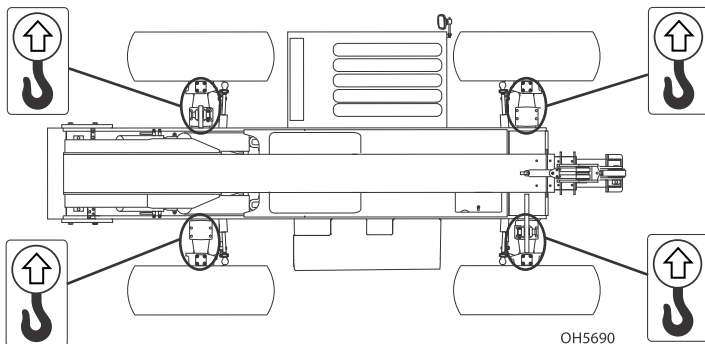

The weight of the machine is listed on the serial number plate located at the front of the frame. Actual machine weight and center of gravity will vary depending on attachment, fluid levels and machine options. Actual weight and center of gravity should be verified prior to lifting.

The following precautions must be taken when lifting the machine with a mobile crane:

- Make adjustments to the lifting device and equipment to ensure that the machine will be level when elevated. The machine must remain level at all times while being lifted.
- Machine must never be lifted by any point on the boom.
- Take care not to let cables, chains, slings, etc. contact any part of the vehicle during lift.

## Operation

---

- The appropriate lifting locations are the axle beams, inboard of the kingpins. Take care as not to damage the axles and components.
- Ensure that the boom is retracted and lowered.
- Ensure that the lifting device and equipment is adequately rated and suitable for the intended purpose.
- Remove all loose items from machine prior to lifting of the machine.
- Lift at a slow, even pace.
- Obtain any additional training regarding the proper lifting procedures that may be required. Please consult the local, state, and employer regulations.

# SECTION 5

## Attachments

---

### 5.1 APPROVED ATTACHMENTS

---

#### 5.1.1 Coupler Mounted Attachments

To determine if an attachment is approved for use on specific telehandler you are using, perform following prior to installation.

- The attachment type, weight and dimensions must be equal to or less than the data shown on a capacity chart located in the operator cab.
- The model on the capacity chart must match the model telehandler being used.
- Hydraulically powered attachments must only be used on machines equipped with auxiliary hydraulics.
- Hydraulically powered attachments that require auxiliary electrics must only be used on machines equipped with auxiliary hydraulics and electrics.
- The attachment is clearly labeled in accordance with ANSI/ITSDF B56.6

If any of the above conditions are not met, do not use attachment. Telehandler may not be equipped with proper capacity chart or attachment may not be approved for the model telehandler being used. Contact JLG or a local distributor for further information.

#### 5.1.2 JLG Supplied Fork Mounted Attachments

To determine if an attachment is approved for use on specific telehandler you are using, perform following prior to installation.

- The machine is authorized for use with JLG supplied fork mounted attachments.
- The model on the capacity chart must match the model telehandler being used.
- Hydraulically powered attachments must only be used on machines equipped with auxiliary hydraulics.
- Hydraulically powered attachments that require auxiliary electrics must only be used on machines equipped with auxiliary hydraulics and electrics.

If any of the above conditions are not met, do not use attachment. Telehandler may not be equipped with proper capacity chart or attachment may not be approved for the model telehandler being used. Contact JLG or a local distributor for further information.

For requirements regarding fork mounted attachments, see [Section - Fork Mounted Attachments](#).

#### 5.1.3 Non-OEM Fork Mounted Attachments

JLG authorizes the use of non-OEM fork mounted attachments provided the criteria and instructions are followed. See [Section - Fork Mounted Attachments](#).

### 5.2 UNAPPROVED ATTACHMENTS

---

Do not use unapproved attachments for the following reasons:

- Range and capacity limitations for “will fit,” homemade, altered, or other non-approved attachments cannot be established.
- An overextended or overloaded telehandler can tip over with little or no warning and cause serious injury or death to the operator and/or those working nearby.
- The ability of a non-approved attachment to perform its intended function safely cannot be assured.

## WARNING

Use only approved attachments. Attachments which have not been approved for use with your telehandler could cause machine damage or an accident.

### 5.3 FORK MOUNTED ATTACHMENTS

---

#### 5.3.1 General Requirements

- Certain fork mounted attachments have a dedicated capacity chart. The attachment type, weight and dimensions must be equal to or less than the data shown on a capacity chart located in the operator cab. If it does not have a dedicated capacity chart, utilize the applicable carriage capacity chart on which the fork mounted attachment is attached.
- Fork mounted attachments are to be used on telehandlers with a standard carriage or side tilt carriage with pallet or lumber forks only.
- All fork mounted attachments must ensure secure connection with pins behind the heel of the forks. Do not secure using chains, straps or clamps directly to the forks, fork carriage, load bar and/or the boom.
- The forks of the carriage must support 2/3 of the load length for any load applied.
- The weight of the fork mounted attachment, rigging and the associated load is to be included in the total load being lifted. Refer to the capacity chart for the carriage in use.
- The capacity chart for the applicable carriage is established with a 24-inch load center, and the load center of the attachment and load must equal 24 inches to utilize the existing load chart capacities.
- When the load center of a combined attachment and/or load exceeds 24 inches, the equivalent load must be calculated to use with the carriage capacity chart. See [Fork Mounted Attachments Equivalent Load](#).

**Note:** When lifting loads, ensure that the center of gravity (CG) of the load being lifted is centered (right to left) between the forks.

### 5.3.2 Non-OEM Attachments

User of non-OEM attachments is responsible for:

- Design
- Fabrication
- Workmanship
- Structural Integrity
- Maximum Capacity
- Fit and Function
- Overall Quality
- Any operation and safety instructions specific to the attachment
- The attachment is clearly labeled in accordance with ANSI/ITSDF B56.6
- Ensure that the attachment and use of the attachment complies with this and all other applicable standards

## 5.4 EQUIVALENT LOAD

---

### 5.4.1 Load Centers Beyond 24 Inches

Carriage and fork capacity charts provided by JLG are validated based on load centers of 24 inches. When the load center for the application being performed exceeds 24 inches, the Equivalent Load must be calculated to use with the carriage capacity chart.

Utilizing Equivalent Load Calculation is applicable for all carriage and fork arrangements. The forks of the JLG carriage must support 2/3 of the load length for any load applied.

#### Equivalent Load Calculation

The Equivalent Load is determined with the calculation below. The Equivalent Load is the value applied to the respective carriage capacity chart to determine the appropriate use zone(s).

$$\frac{\text{Weight of Attachment Load (lb)} \times \text{CG Distance of Load (in)}^1}{24 \text{ in}} = \text{Equivalent Load}$$

<sup>1</sup> Center of Gravity (CG) Distance is measured horizontally from the front surface of the fork.

#### Example

- Weight of load = 5,000 pounds
- Center of gravity of load = 36 inches

The Equivalent Load for this example is:

$$\frac{5,000 \times 36}{24} = 7,500 \text{ pounds}$$

This value is cross-checked to the capacity of the forks to ensure the forks are rated to equally share this load. The user then utilizes the carriage capacity chart to determine where 7,500 lb can be safely moved and placed within the machine operating limits.

## 5.4.2 Fork Mounted Attachments Equivalent Load

### Equivalent Load Calculation

The Equivalent Load is determined with the calculation below. The Equivalent Load is the value applied to the respective carriage capacity chart to determine the appropriate use zone(s).

$$\text{Weight of Attachment (lb) x CG Distance of Attachment (in)}^1 + (\text{Weight of Attachment Load (lb) x CG Distance of Load (in)}^1) \div 24 \text{ in} = \text{Equivalent Load}$$

<sup>1</sup> Center of Gravity (CG) Distance is measured horizontally from the front surface of the fork.

#### Example

- Weight of attachment = 500 pounds
- Center of gravity of attachment = 36 inches
- Weight of load = 1,000 pounds
- Center of gravity of load = 45 inches

The Equivalent Load for this example is:

500 X 36	=	18000
1000 X 45	=	45000
18,000 + 5000	=	2,625 pounds
24	=	

This value is cross-checked to the capacity of the forks to ensure the forks are rated to equally share this load. The user then utilizes the carriage capacity chart to determine where 2,625 lb can be safely moved and placed within the machine operating limits.

WARNING

This calculation does not apply to Personnel Work Platforms. Refer to Telehandler Personnel Work Platform Operation & Safety Manual for additional information.

## 5.5 JLG SUPPLIED ATTACHMENTS

Attachment	Part Number	Applicable Model					
		6036	6042	8042	1000-42	10054	12054
Carriage, 50 in (1270 mm)	1001146084	X	X	X	X	X	
	1170021	X	X	X	X	X	X
Carriage, 60 in (1524 mm)	1001146086	X	X	X	X	X	
	1170024	X	X	X	X	X	X
Carriage, 72 in (1829 mm)	1001146088	X	X	X	X	X	
	1001193794	X	X	X	X	X	
	1001211516	X	X	X	X	X	X
Side Shift Carriage, 50 in (1270 mm)	1001242644	X	X	X	X	X	X
Side Tilt Carriage, 50 in (1270 mm)	1170054	X	X	X	X	X	X
	1001233383	X	X	X	X	X	X
	1001277290	X	X	X	X	X	X
Side Tilt Carriage, 60 in (1524 mm)	1001101956	X	X	X	X	X	X
	1001233384	X	X	X	X	X	X
	1001277338	X	X	X	X	X	X
Side Tilt Carriage, 72 in (1829 mm)	1170057	X	X	X	X	X	X
	1001233385	X	X	X	X	X	X
	1001276666	X	X	X	X	X	X
90° Swing Carriage, 72 in (1829 mm)	1001095418	X	X	X	X	X	X
Dual Fork Positioning Carriage, 50 in (1270 mm)	7301295	X	X	X	X	X	X
	1001189211	X					X
8 ft Mast Carriage, 50 in (1270 mm)	1001108668	X	X	X	X	X	X
Pipe Grapple	1001142247	X			X	X	X
Fork, Pallet 2.36x4x48 in (60x100x1220 mm)	2340045	X	X	X	X	X	
Fork, Pallet 2.36x5x48 in (60x127x1220 mm)	2340038	X	X	X	X	X	X



Attachment	Part Number	Applicable Model					
		6036	6042	8042	1000-42	10054	12054
Fork, Pallet 2.36x4x48 in (60x100x1220 mm)	7301408	X	X	X	X	X	
Fork, Pallet 2.36x4x60 in (60x100x1524 mm)	1001227379	X	X	X	X	X	
Fork, Pallet 2.36x5x72 in (60x127x1830 mm)	1001232355	X	X	X	X	X	X
Fork, Pallet 2.36x5x60 in (60x127x1524 mm)	1001227382	X	X	X	X	X	X
Fork, Pallet 2.36x6x60 in (60x152x1524 mm)	2340039	X	X	X	X	X	X
Fork, Pallet 2x7x60 in (50x178x1524 mm)	1001097110						X
Fork, Dual Taper 1.75x7x60 in (44x178x1524 mm)	2340046	X	X	X	X	X	
Fork, Dual Taper 2x6x72 in (50x152x1830 mm)	1001259206	X	X	X	X	X	X
Fork, Block 2x2x48 in (50x50x1220 mm)	2340037	X	X	X	X	X	X
Fork Extension, 90 in (2286 mm)	1001137512	X	X	X	X	X	X
Trash Hopper, Fork Mounted	1001238566	X	X	X	X	X	X
Bucket, Fork Mounted 60 in–1.3 yd <sup>3</sup>	1001195970	X	X	X	X	X	X
Bucket, 72 in–1.0 yd <sup>3</sup>	1001100822	X	X	X	X	X	X
Bucket, 96 in–1.5 yd <sup>3</sup>	1001100823	X	X	X	X	X	X
Bucket, 102 in–2.0 yd <sup>3</sup>	1001100824	X	X	X	X	X	X
Grapple Bucket, 96 in–1.75 yd <sup>3</sup>	0930020	X	X	X	X	X	X
Hook, Fork Mounted	1001097205	X	X	X	X	X	X
Hook, Coupler Mounted	1001207606	X	X	X	X	X	X
Truss Boom w/ Winch, 3 ft (914 mm)	1001100967	X	X	X	X	X	X

## Attachments

Attachment	Part Number	Applicable Model					
		6036	6042	8042	1000-42	10054	12054
Truss Boom, 12 ft (3658 mm)	1001099902	X	X	X	X	X	X
	1001275853	X	X	X	X	X	X
Truss Boom w/ Winch, 12 ft (3658 mm)	1001099351	X	X	X	X	X	X
Truss Boom, 15 ft (4572 mm)	1001099901	X	X	X	X	X	X
	1001275852	X	X	X	X	X	X
Truss Boom, Adjustable	1001230241	X	X	X	X	X	X
Material Handling Arm	1001176515	X	X	X	X	X	X
Platform, Fork Mounted (ASME)	1001238653	X	X	X	X	X	X
Platform, Fork Mounted (ASME - French)	1001238655	X	X	X	X	X	X
Platform, Fork Mounted (ISO)	1001238654	X	X	X	X	X	X
Sweeper	1001202904	X	X	X	X	X	X
Sheet Handler	1001100227	X	X	X	X	X	X

## 5.6 TELEHANDLER/ATTACHMENT/FORK CAPACITY

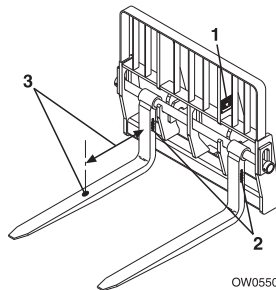

Prior to installing attachment, verify it is approved and telehandler is equipped with proper capacity chart. See [Section — Approved Attachments](#).

To determine maximum capacity of telehandler and attachment, use the smallest of the following capacities:

- Capacity stamped on attachment identification plate **(1)**.
- Fork capacities and load centers are stamped on the side of each fork **(2)** (if equipped). This rating specifies maximum load capacity that the individual fork can safely carry at maximum load center **(3)**. Total attachment capacity is multiplied by number of forks on attachment (if equipped), up to maximum capacity of attachment.
- Maximum capacity as indicated on the proper capacity chart. See [Section — Approved Attachments](#).
- When load rating of telehandler differs from capacity of the forks or attachment, the lower value becomes the overall load capacity.

Use the proper capacity chart to determine maximum capacity at various machine configurations. Lifting and placing a load may require use of more than one capacity chart based on machine configuration.

Other than block forks, all forks should be used in matched pairs, block forks used in matched sets.

### **⚠ WARNING**

Never use an attachment without the appropriate JLG approved capacity chart installed on the telehandler.

## 5.7 USE OF THE CAPACITY CHART

To properly use capacity chart (see [Sample Capacity Chart, page 85](#)) operator must first determine and/or have the following:

1. An approved attachment. See [Section — Approved Attachments](#).

## Attachments

---

2. Proper Capacity Chart(s).
3. Weight of load being lifted.
4. Load placement information:
  - a. HEIGHT where load is to be placed.
  - b. DISTANCE from front tires of telehandler where load is to be placed.
5. On capacity chart, find the line for height and follow it over to distance.
6. Number in load zone where the two cross is the maximum capacity for this lift. If the two cross at a division between zones, the smaller number must be used.

The number in load zone must be equal to or greater than weight of load to be lifted. Determine limits of load zone on capacity chart and keep within these limits.

### 5.7.1 Capacity Indicator Locations

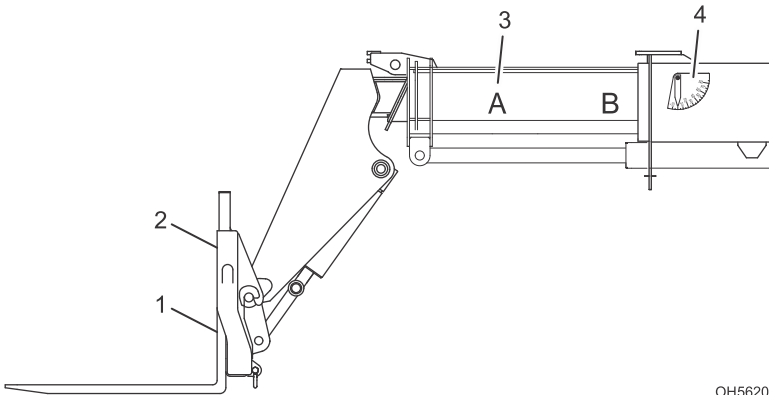

OH5620

1. Fork Weight Stamp	2. Attachment Identification Plate	3. Boom Extension Indicator	4. Boom Angle Indicator
----------------------	------------------------------------	-----------------------------	-------------------------

## 5.7.2 Sample Capacity Chart

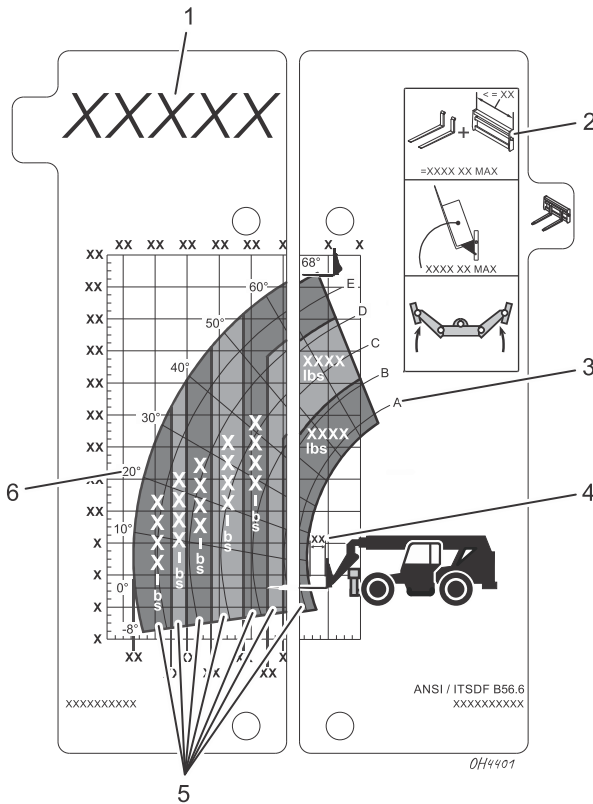

1. This Capacity Chart may be used with this model ONLY. The telehandler model is indicated on the boom or chassis. Model XXXXX is used for demonstration purposes only.

3. Boom Extension Indicator (arc)

5. Load zones indicate the maximum weight that may be safely lifted.

2. Attachment type, weight and dimensions must be equal to or less than the data shown.

4. Load center must be equal to or less than value shown.

6. Boom Angle

**Note:** This is sample capacity chart **only! DO NOT** use this chart, use the one located in your operator cab.

# ⚠ WARNING

**TIP OVER HAZARD.** All loads shown on rated capacity chart are based on machine being on firm ground with frame level (see [Section — Transporting a Load](#) or [Section - Transporting a Suspended Load](#)); the forks being positioned evenly on carriage; the load being centered on forks; proper size tires being properly inflated; and the telehandler being in good operating condition.

To identify the proper capacity chart on telehandlers equipped with outriggers, refer to the following icons which may be located on the capacity chart.

- Use when lifting a load with outriggers up.

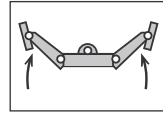

- Use when lifting a load with outriggers down.

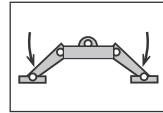

### 5.7.3 Example

A contractor owns a model xxxx telehandler with a fork carriage. The contractor knows this attachment may be used with his model since:

- The part number on the attachment identification plate matches the attachment part number on a capacity chart located in the operator cab.
- Attachment style, weight, dimensions and load center match the attachment data on the capacity chart.
- Capacity chart is clearly marked for model xxxx and corresponds with machine configuration being used.

Below are examples with various conditions the contractor may encounter and whether or not the load may be lifted.

	Load Weight	Distance	Height	OK to Lift
1	6000 lb (2722 kg)	18 ft (5,5 m)	12 ft (3,7 m)	Yes
2	4000 lb (1814 kg)	30 ft (9,1 m)	26 ft (7,9 m)	NO
3	7500 lb (3402 kg)	8 ft (2,4 m)	24 ft (7,3 m)	Yes
4	5750 lb (2608 kg)	12 ft (3,7 m)	44 ft (13,4 m)	NO

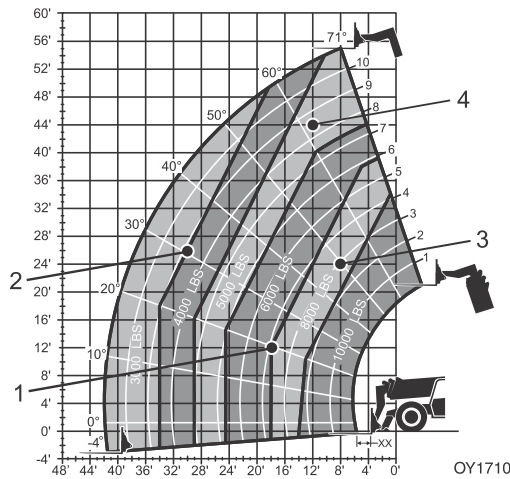

**Note:** This is a sample capacity chart **only! DO NOT** use this chart, use the one located in your operator cab.

## ⚠ WARNING

**TIP OVER HAZARD.** All loads shown on rated capacity chart are based on machine being on firm ground with frame level, the forks being positioned evenly on carriage; the load being centered on forks; proper size tires being properly inflated; and the telehandler being in good operating condition.

To identify the proper capacity chart on telehandlers equipped with outriggers, refer to the following icons which may be located on the capacity chart.

- Use when lifting a load with outriggers up.

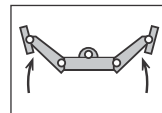

- Use when lifting a load with outriggers down.

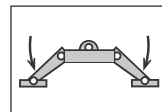

### 5.7.4 Example

A contractor owns a model xxxxx telehandler with a fork carriage. He knows this attachment may be used with his model since:

- The attachment style, weight, dimensions and load center match the attachment data on the capacity chart.
- The capacity chart is clearly marked for model xxxxx and corresponds with machine configuration being used.

Below are examples with various conditions the contractor may encounter and whether or not the load may be lifted.

	Load Weight	Distance	Height	OK to Lift
1	6000 lb (2722 kg)	18 ft (5,5 m)	12 ft (3,7 m)	Yes
2	4000 lb (1814 kg)	30 ft (9,1 m)	26 ft (7,9 m)	NO
3	7500 lb (3402 kg)	8 ft (2,4 m)	24 ft (7,3 m)	Yes
4	5750 lb (2608 kg)	12 ft (3,7 m)	44 ft (13,4 m)	NO

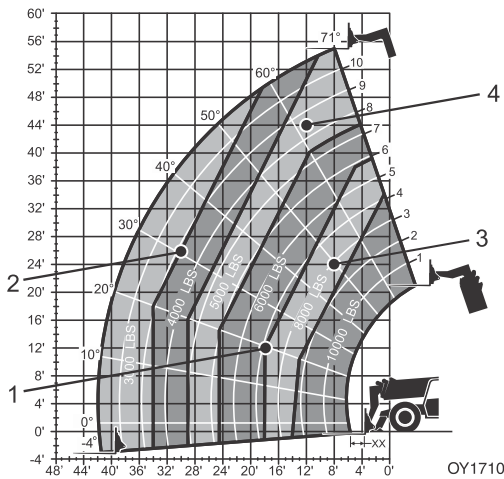

This is a sample capacity chart **only!** DO NOT use this chart, use the one located in your operator cab.



## 5.8 ATTACHMENT INSTALLATION

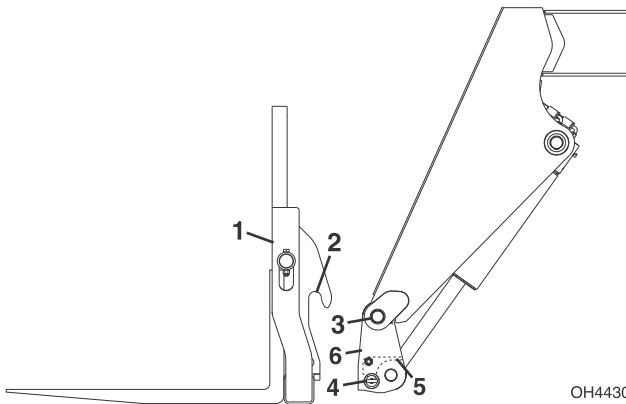

1. Attachment
2. Attachment Pin Recess
3. Attachment Pin
4. Lock Pin
5. Lock Lever
6. Quick Coupler (attachment tilt control in cab)

### **⚠ WARNING**

**CRUSH HAZARD.** Always be certain that carriage or attachment is properly positioned on boom and is secured by lock pin and lock lever. Failure to ensure proper installation could permit carriage/attachment/load to disengage.

This installation procedure is designed for one-person operation. Prior to exiting cab, perform "Shut-Down Procedure".

1. Tilt quick coupler back to provide clearance. Check to be sure lock pin is removed.

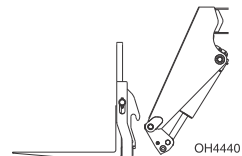

2. Align attachment pin with recess in attachment. Raise boom slightly to engage attachment pin in recess.

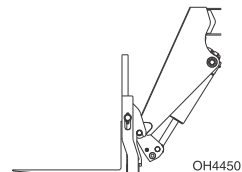

3. Tilt quick coupler forward to engage attachment.

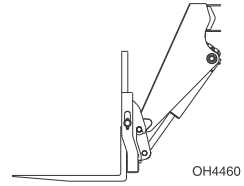

4. Lift lock lever and insert lock pin completely through quick coupler. Release lock lever and ensure lock pin is secured.

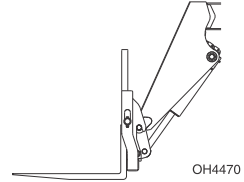

5. If equipped, connect auxiliary hydraulic hoses. See "Hydraulic Operated Attachment".

### 5.8.1 Hydraulic Operated Attachment

1. Install attachment.
2. Lower attachment to ground and perform "Shut-Down Procedure".

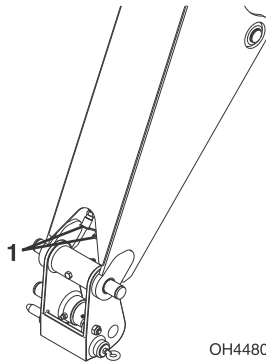

3. Connect attachment hoses to both auxiliary fittings (1).

## 5.9 ADJUSTING/MOVING FORKS

---

Carriages may have different locations where forks can be positioned. Two different methods can be used for repositioning, depending upon carriage structure.

**Note:** Apply a light coating of appropriate lubricant to ease sliding of forks or fork bar.

### To slide forks:

1. Ensure attachment is properly installed. See [Section — Attachment Installation](#).

2. If equipped, loosen fork locking bolt.
3. Elevate attachment to approximately 5 ft (1,5 m) and tilt carriage forward until fork heel is free from attachment.
4. Stand at side of carriage. To slide fork toward center of carriage, push fork near fork eye. To slide fork toward edge of carriage, pull fork near fork eye. To avoid pinching, do not place fingers or thumb between fork and carriage structure.
5. If equipped, tighten fork locking bolt.

**If removing fork bar is necessary:**

1. Rest forks on ground.
2. If equipped, loosen fork locking bolt.
3. Remove fork bar.
4. Reposition forks.
5. Reinstall the fork bar and fork bar retaining mechanism(s).
6. If equipped, tighten fork locking bolt.

**5.10 ATTACHMENT OPERATION**

- Capacities and range limits for telehandler change depending on attachment in use.
- Separate attachment instructions must be kept in manual holder in cab with this Operation & Safety Manual. An additional copy must be kept with attachment if it is equipped with a manual holder.

**NOTICE**

**EQUIPMENT DAMAGE.** Some attachments may contact front tires or machine structure when the boom is retracted and the attachment is rotated. Improper use of attachment may result in attachment or machine structural damage.

**NOTICE**

**EQUIPMENT DAMAGE.** Avoid contact with any structure or object when lifting a load. Maintain clearance around boom structure and load. Failure to maintain clearance may result in attachment or machine structural damage.

### 5.10.1 Carriage with Forks



Use Carriage Attachment Capacity Chart.

To determine maximum capacity, refer to [Section — Telehandler/Attachment/Fork Capacity](#).

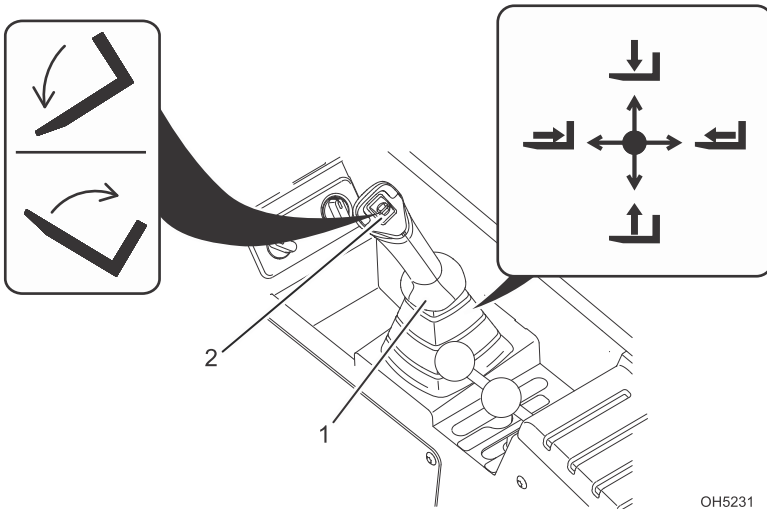

Joystick **(1)** controls movement of the boom.

Roller switch **(2)** controls fork tilt.

- Move joystick back to tilt up.
- Move joystick forward to tilt down.

#### Installation Procedure:

- Refer to [Section — Attachment Installation](#).

#### Equipment Damage Precautions:

- Do not use forks as a lever to pry material. Excessive prying forces could damage forks or machine structure.
- Do not attempt to lift loads that are attached or connected to another object.

## 5.10.2 Side Shift Carriage



Use Side Shift Carriage Capacity Chart.

To determine maximum capacity, refer to [Section — Telehandler/Attachment/Fork Capacity](#).

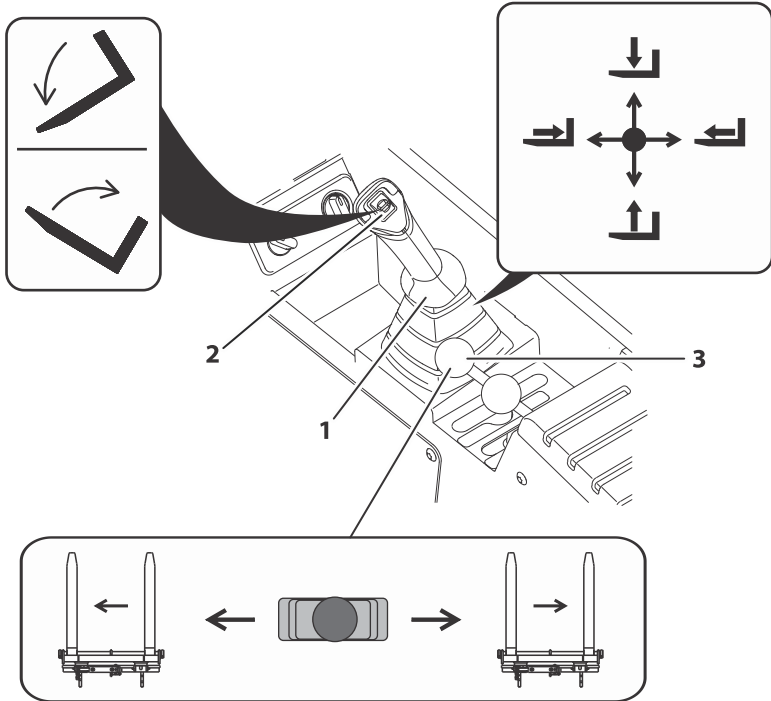

TH000206A

Joystick (1) controls movement of the boom

Roller switch (2) controls fork tilt.

- Press roller switch down to tilt up.
- Press roller switch up to tilt down.

### To Side Shift:

Roller switch (3) controls carriage side shift.

- Move lever left to shift left.
- Move lever right to shift right.

### Installation Procedure:

Refer to [Section — Attachment Installation](#).

# WARNING

**CRUSH HAZARD.** Do not use side shift to push or pull objects or load. Failure to comply could cause object or load to fall.

### Equipment Damage Precautions:

- Do not use forks as a lever to pry material. Excessive prying forces could damage forks or machine structure.
- Do not attempt to lift loads that are attached or connected to another object.

### 5.10.3 Side Tilt Carriage

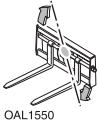

Use Side Tilt Carriage Attachment Capacity Chart.

To determine maximum capacity, refer to [Section — Telehandler/Attachment/Fork Capacity](#).

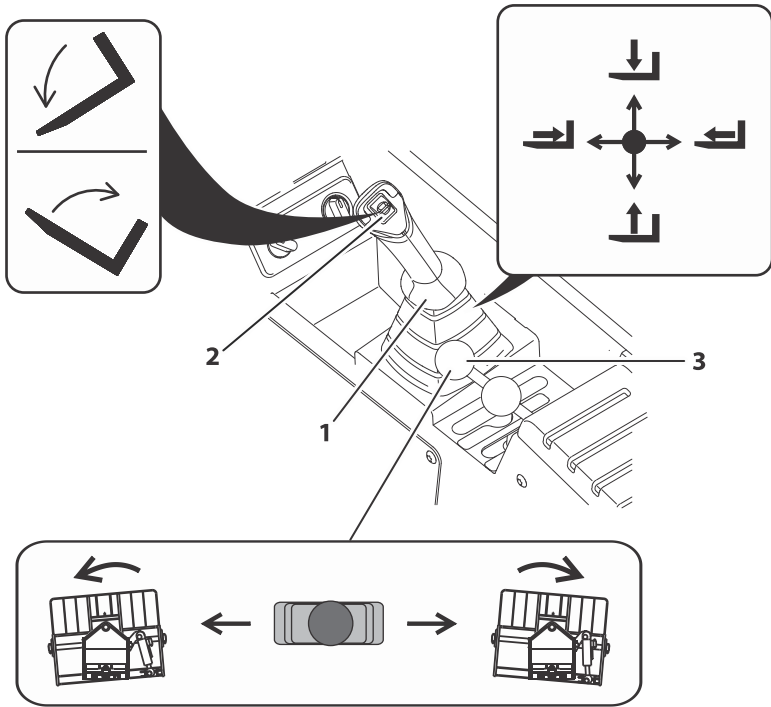

TH000207A

Joystick **(1)** controls movement of the boom

Roller switch **(2)** controls fork tilt.

- Press roller switch down to tilt up.
- Press roller switch up to tilt down.

**To Side Tilt:**

Roller switch **(3)** controls carriage side tilt.

- Move lever left to side tilt left.
- Move lever right to side tilt right.

**Installation Procedure:**

Refer to [Section — Attachment Installation](#).

# **WARNING**

**CRUSH HAZARD.** Do not use side tilt to push or pull objects or load. Failure to comply could cause object or load to fall.

### **Operation:**

- Approach load with forks centered on load and stop telehandler.
- Level telehandler before side tilting carriage to engage load.
- Side tilt carriage to left or right to align forks with load and engage load.
- Raise load slightly and level carriage side to side.
- Travel in accordance with requirements set forth in [Section — General Safety Practices](#).

### **Equipment Damage Precautions:**

- Do not use forks as a lever to pry material. Excessive prying forces could damage forks or machine structure.
- Do not attempt to lift loads that are attached or connected to another object.



## 5.10.4 Swing Carriage

Use Swing Carriage Attachment Capacity Chart.

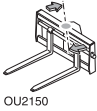

To determine maximum capacity, refer to [Section — Telehandler/Attachment/Fork Capacity](#).

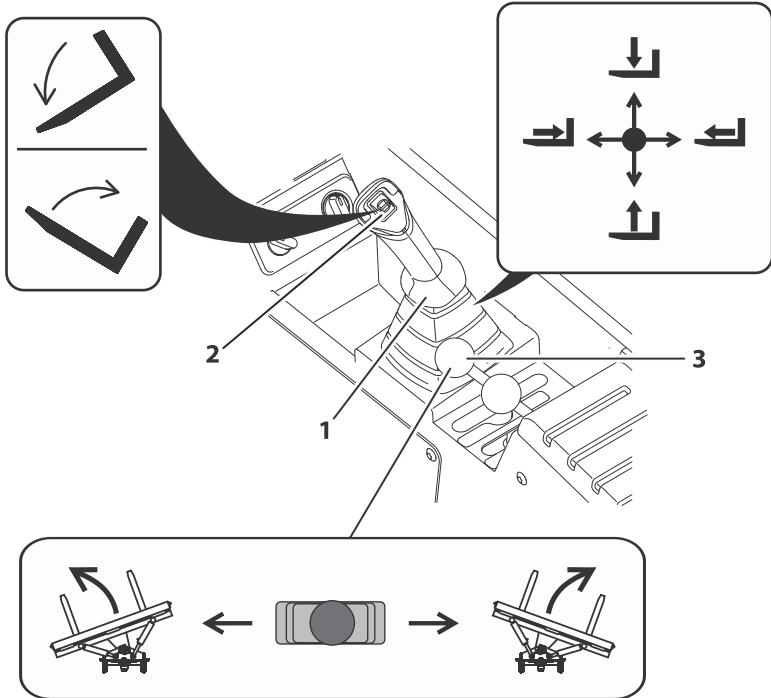

TH000208A

Joystick **(1)** controls movement of the boom

Roller switch **(2)** controls fork tilt.

- Press roller switch down to tilt up.
- Press roller switch up to tilt down.

### To Swing:

Roller switch **(3)** controls carriage swing.

- Move lever left to swing left.
- Move lever right to swing right.

### Installation Procedure:

- Refer to [Section — Attachment Installation](#).

## WARNING

**CRUSH HAZARD.** Always level forks (horizontally) and telehandler frame before swinging load to side. Swinging unlevel forks could cause load to slide off forks.

## WARNING

**CRUSH HAZARD.** Do not use swing carriage to push or pull objects or load. Failure to comply could cause object or load to fall.

## WARNING

**CRUSH HAZARD.** Use retaining pin (if equipped) for locking swing frame to fixed frame when carrying loads greater than 5000 lb (2268 kg). Failure to comply could cause object or load to fall.

### Operation:

- To drive with a load, keep forks pointed forward and travel in accordance with requirements set forth in [Section — General Safety Practices](#).

### Equipment Damage Precautions:

- Do not use forks as a lever to pry material. Excessive prying forces could damage forks or machine structure.
- Do not attempt to lift loads that are attached or connected to another object.

## 5.10.5 Dual Fork Positioning Carriage



Use Carriage Attachment Capacity Chart (6036, 6042, 8042, 10042 & 10054).

Use Dual Fork Positioning Carriage Attachment Capacity Chart (12054).

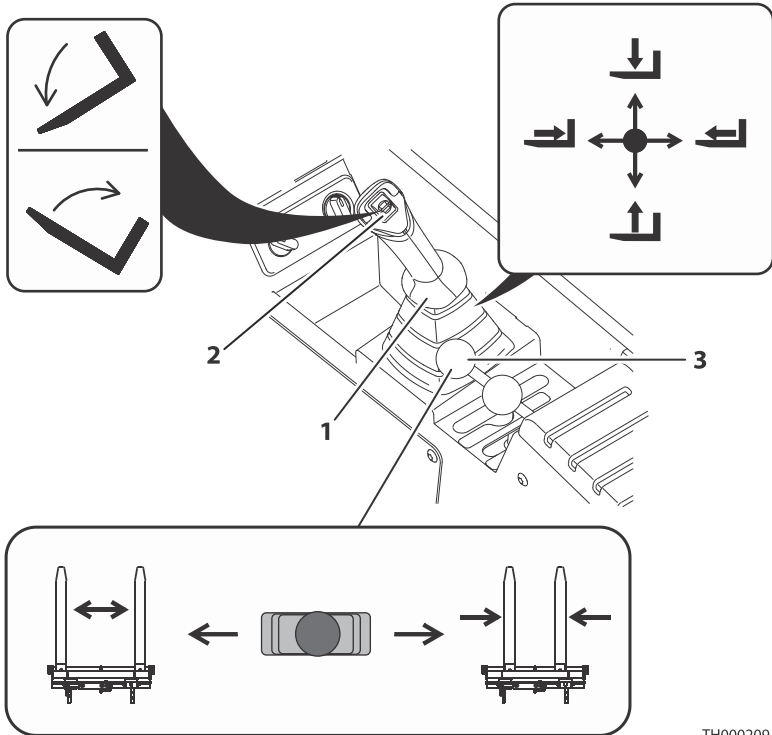

TH000209A

Joystick **(1)** controls movement of the boom

Roller switch **(2)** controls fork tilt.

- Press roller switch down to tilt up.
- Press roller switch up to tilt down.

### To Fork Position:

Roller switch **(3)** controls fork position.

- Move lever left to shift forks out.
- Move lever right to shift forks in.

### Installation Procedure:

- Refer to [Section — Attachment Installation](#).

## WARNING

**CRUSH HAZARD.** Do not use fork positioning to push or pull objects or load. Failure to comply could cause object or load to fall.

### Operation:

- Travel in accordance with requirements set forth in [Section — General Safety Practices](#).

### Equipment Damage Precautions:

- Do not use forks as a lever to pry material. Excessive prying forces could damage forks or machine structure.
- Do not attempt to lift loads that are attached or connected to another object.

## 5.10.6 Mast Carriage



Use Mast Carriage Attachment Capacity Chart.

To determine maximum capacity, refer to [Section — Telehandler/Attachment/Fork Capacity](#).

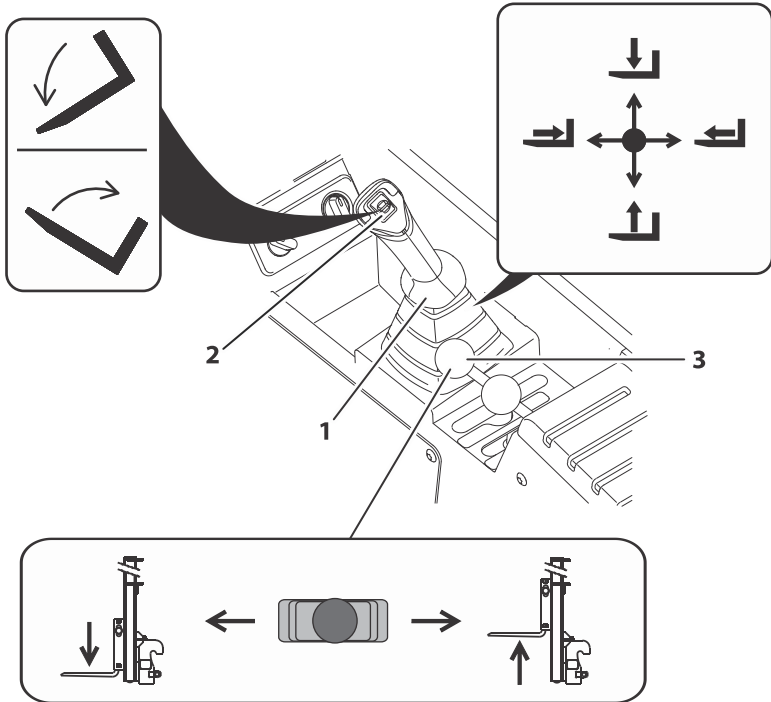

TH000210A

Joystick **(1)** controls movement of the boom

Roller switch **(2)** controls fork tilt.

- Press roller switch down to tilt up.
- Press roller switch up to tilt down.

### To Raise/Lower Mast:

Auxiliary hydraulic lever**(3)** controls the raise/lower movement of the mast.

- Move lever left to lower.
- Move lever right to raise.

### Installation Procedure:

- Refer to [Section — Attachment Installation](#).

## WARNING

**CRUSH HAZARD.** Do not use mast to push or pull objects or load. Failure to comply could cause object or load to fall.

### Operation:

- Always lower forks fully in mast before engaging load.
- To drive with a load, lower forks fully in mast and travel in accordance with requirements set forth in [Section — General Safety Practices](#).
- Use a signal person to assist in positioning of load if necessary.

### Equipment Damage Precautions:

- Do not use forks as a lever to pry material. Excessive prying forces could damage forks or machine structure.
- Do not attempt to lift loads that are attached or connected to another object.

## 5.10.7 Pipe Grapple



Use Pipe Grapple Attachment Capacity Chart

To determine maximum capacity, refer to [Section — Telehandler/Attachment/Fork Capacity](#).

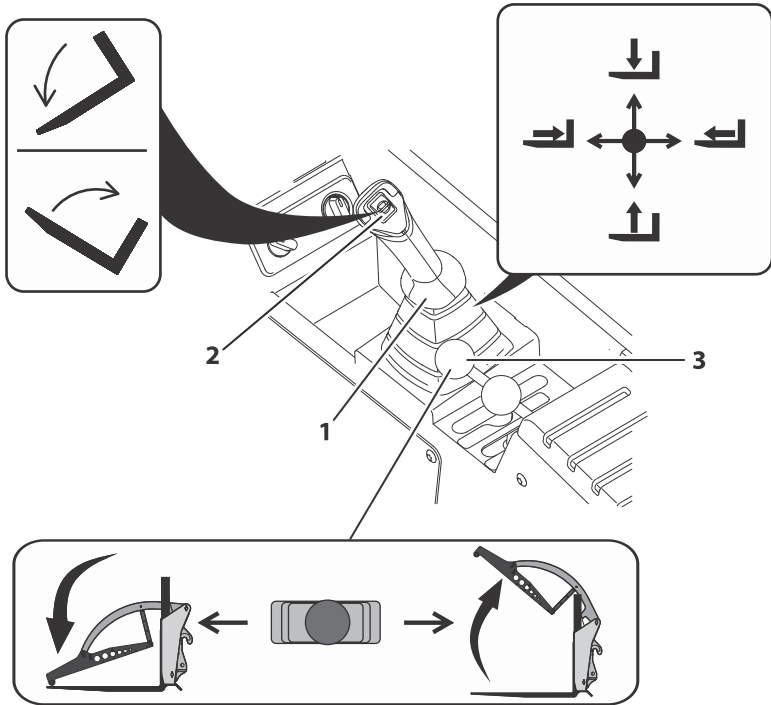

TH000211A

Joystick **(1)** controls movement of the boom.

Roller switch **(2)** controls pipe grapple tilt.

- Press roller switch down to tilt up.
- Press roller switch up to tilt down.

### To Open/Close Pipe Grapple:

Roller switch **(3)** controls the open/close movement of the pipe grapple.

- Move lever left to close pipe grapple.
- Move lever right to open pipe grapple.

### **Installation Procedure:**

Refer to [Section — Attachment Installation](#).

### **Operation:**

- Raise or lower boom to appropriate height and open pipe grapple for loading material.
- Align and center telehandler with face of material.
- Drive slowly and smoothly into material for loading. Boom extension may be required for loading material.
- Center load on forks, tilt forks up far enough to retain load, close pipe grapple and back away.
- Travel in accordance with requirements set forth in [Section — General Safety Practices](#).
- Open pipe grapple and unload material from forks.

### **Equipment Damage Precautions**

- Except for lifting or unloading material, the boom must be fully retracted for all operations.
- Do not use forks as a lever to pry material. Excessive prying forces could damage forks or machine structure.
- Do not use pipe grapple as a lever to pry material. Excessive prying forces could damage pipe grapple or machine structure.
- Do not attempt to load material which is hard or frozen. This could cause severe damage to coupler or machine structure.
- Do not attempt to lift loads that are attached or connected to another object.



## 5.10.8 Fork Extension

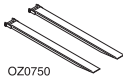

Use Appropriate Carriage Attachment Capacity Chart.

To determine maximum capacity, refer to [Section — Telehandler/Attachment/Fork Capacity](#). The maximum capacity of the carriage when equipped with fork extensions may be reduced to the capacity indicated on the fork extensions. If the load exceeds the capacity of the fork extension, contact JLG to obtain forks and/or fork extensions of the proper load rating and length.

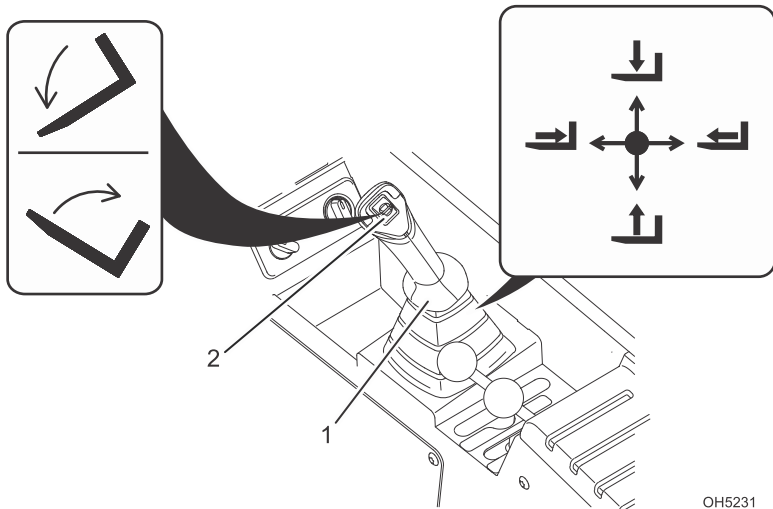

OH5231

Joystick **(1)** controls movement of the boom

Roller switch **(2)** controls fork tilt.

- Press roller switch down to tilt up.
- Press roller switch up to tilt down.

### Installation Procedure:

- Ensure carriage is properly installed. Refer to [Section — Attachment Installation](#).
- Ensure length and cross section of the parent fork arm is equal to or exceeds the parent fork arm blade length stamped into the fork extension.
- Secure the fork extensions to the forks by sliding the fork extensions onto the parent forks and install the retaining pin behind the vertical shank of the fork.

### Operation:

- Heavy part of load must be against carriage backrest.

## Attachments

---

- Do not allow load center of gravity to be in front of tip of the supporting fork.
- Do not pick up a load or pry materials with tip of fork extensions.

## 5.10.9 Coupler Mounted Hook

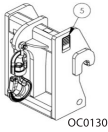

Use Appropriate Coupler Mounted Hook Capacity Chart.

To determine maximum capacity, refer to [Section — Telehandler/Attachment/Fork Capacity](#).

Suspend loads in accordance with requirements set forth in [Section — General Safety Practices](#).

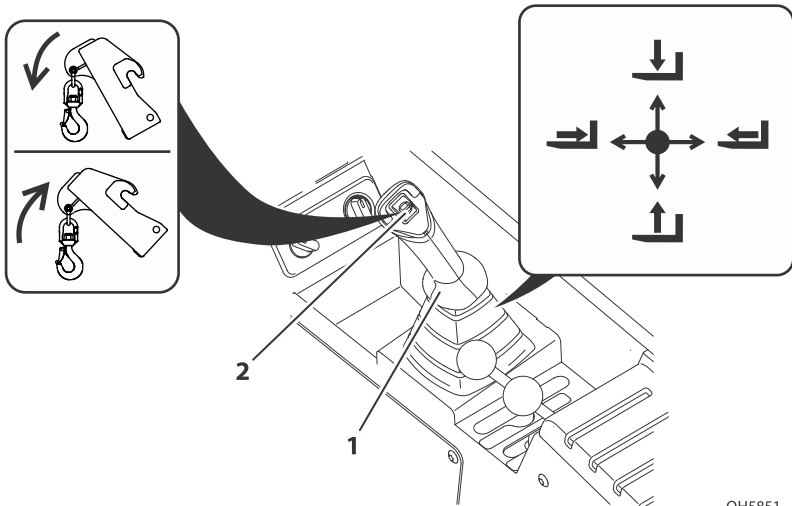

OH5851

Joystick **(1)** controls movement of the boom

Roller switch **(2)** controls coupler mounted hook tilt.

- Press roller switch down to tilt up.
- Press roller switch up to tilt down.

### Installation Procedure:

- Refer to [section — Attachment Installation](#).

### Operation:

- Weight of rigging must be included as part of total load being lifted.

### 5.10.10 Fork Mounted Hook

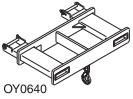

Use Appropriate Carriage Attachment Capacity Chart.

To determine maximum capacity, refer to [Section — Telehandler/Attachment/Fork Capacity](#).

**Suspend loads in accordance with requirements set forth in [Section — General Safety Practices](#).**

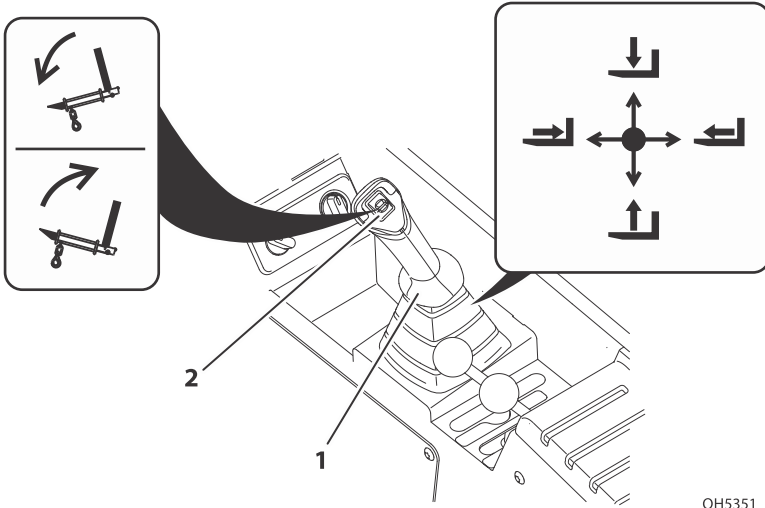

Joystick **(1)** controls movement of the boom

Roller switch **(2)** controls fork tilt.

- Press roller switch down to tilt up.
- Press roller switch up to tilt down.

#### Installation Procedure:

- Ensure carriage is properly installed. Refer to [Section — Attachment Installation](#).
- Secure the fork mounted hook to the forks by sliding the fork mounted hook onto the parent forks and install the retaining pin behind the vertical shank of the fork.

#### Operation:

- Pallet or lumber forks of an appropriate load rating must be used. Do not use with cubing or block forks.
- Fork mounted hook and rigging weight must be included as part of total load being lifted.
- Do not use with mast carriage attachment.

- Do not use fork mounted hook with attachments capable of rotating (i.e. side tilt and swing carriages) without disabling the rotation feature(s).

### 5.10.11 Bucket

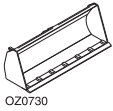

Use Appropriate Bucket Capacity Chart.

To determine maximum capacity, refer to [Section — Telehandler/Attachment/Fork Capacity](#).

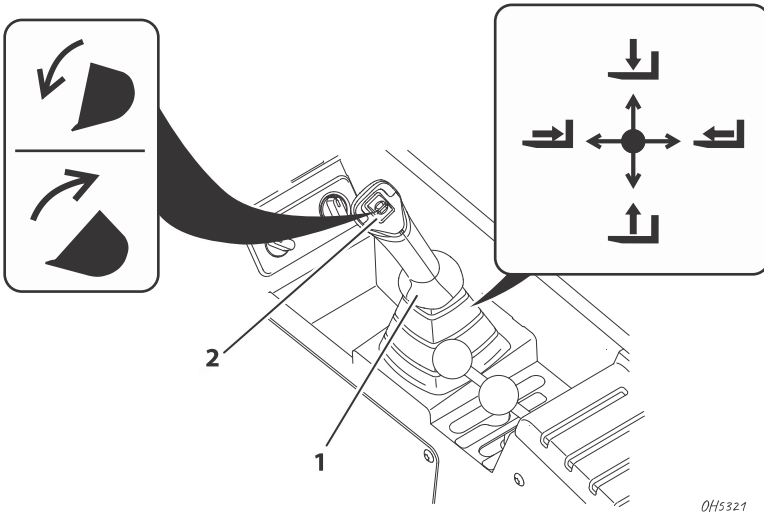

Joystick (1) controls movement of the boom

Roller switch (2) controls bucket tilt.

- Press roller switch down to tilt up.
- Press roller switch up to tilt down.

#### Installation Procedure:

- Refer to [Section — Attachment Installation](#).

#### Operation:

- Raise or lower boom to appropriate height for loading material from stockpile.
- Align telehandler with face of stockpile and drive slowly and smoothly into pile to load bucket.
- Tilt bucket up far enough to retain load and back away from pile.
- Travel in accordance with requirements set forth in [Section — General Safety Practices](#).
- Tilt bucket down to dump load.

**Equipment Damage Precautions**

- Except for lifting or dumping a load, the boom must be fully retracted for all bucket operations.
- Do not corner-load bucket. Distribute material evenly within the bucket. Bucket capacity charts are for evenly distributed loads only.
- Do not use bucket as a lever to pry material. Excessive prying forces could damage bucket or machine structure.
- Do not attempt to load material which is hard or frozen. This could cause severe damage to coupler or machine structure.
- Do not use bucket for "back dragging." This could cause severe damage to coupler and retraction cables/chains.

### 5.10.12 Grapple Bucket



Use Grapple Bucket Capacity Chart.

To determine maximum capacity, refer to [Section — Telehandler/Attachment/Fork Capacity](#).

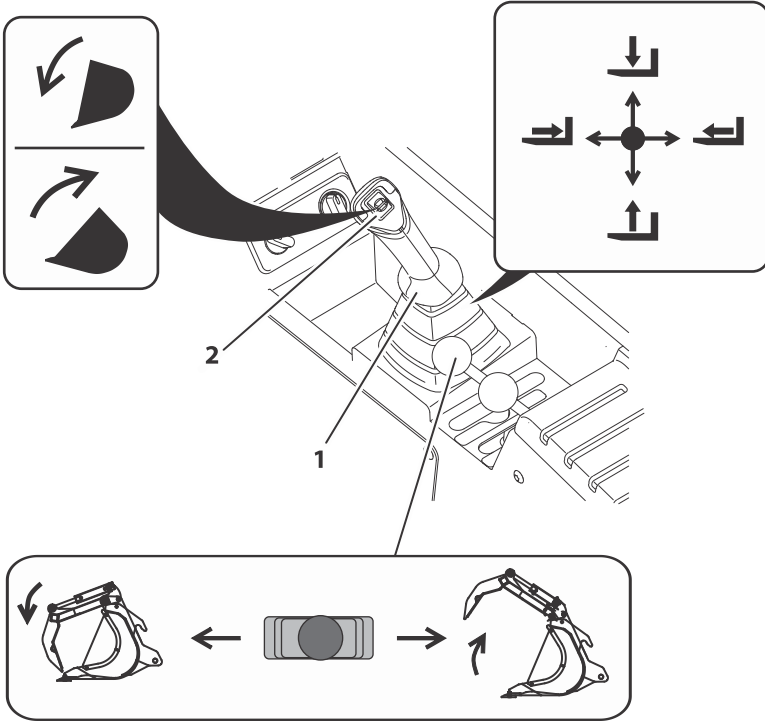

TH000212A

Joystick (1) controls movement of the boom

Roller switch (2) controls grapple bucket tilt.

- Press roller switch down to tilt up.
- Press roller switch up to tilt down.

#### To Open/Close Grapple:

Roller switch (3) controls the open/close movement of the grapple.

- Press roller switch down to close grapple.
- Press roller switch up to open grapple.



---

**Installation Procedure:**

- Refer to [Section — Attachment Installation](#).

**Operation:**

- Raise or lower boom to appropriate height and open grapple for loading material from stockpile.
- Align telehandler with face of stockpile and drive slowly and smoothly into pile to load bucket.
- Tilt bucket up far enough to retain load, close grapple and back away from pile.
- Travel in accordance with requirements set forth in [Section — General Safety Practices](#).
- Open grapple and tilt bucket down to dump load.

**Equipment Damage Precautions**

- Except for lifting or dumping a load, the boom must be fully retracted for all bucket operations.
- Do not corner-load bucket. Distribute material evenly within the bucket. Bucket capacity charts are for evenly distributed loads only.
- Do not use bucket as a lever to pry material. Excessive prying forces could damage bucket or machine structure.
- Do not attempt to load material which is hard or frozen. This could cause severe damage to coupler or machine structure.
- Do not use bucket for "back dragging." This could cause severe damage to coupler and retraction cables/chains.

### 5.10.13 Bucket - Fork Mounted

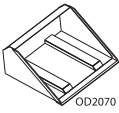

Use Appropriate Carriage Attachment Capacity Chart.

To determine maximum capacity, refer to [Section — Telehandler/Attachment/Fork Capacity](#).

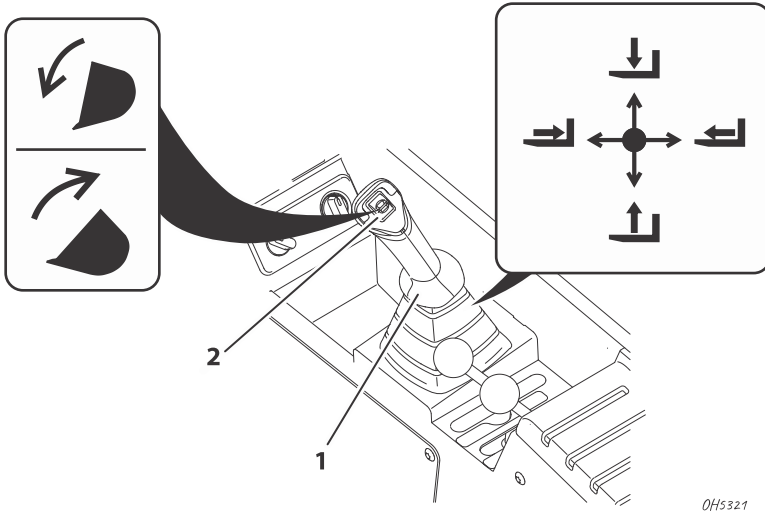

Joystick **(1)** controls movement of the boom

Roller switch **(2)** controls bucket tilt.

- Press roller switch down to tilt up.
- Press roller switch up to tilt down.

#### Installation Procedure:

- Ensure carriage is properly installed. Refer to [Section — Attachment Installation](#).
- Secure the fork mounted bucket to the forks by sliding the fork mounted bucket onto the parent forks and install the retaining pin behind the vertical shank of the fork.

#### Operation:

- Raise or lower boom to appropriate height for loading material from stockpile.
- Align telehandler with face of stockpile and drive slowly and smoothly into pile to load bucket.
- Tilt bucket up far enough to retain load and back away from pile.

- Travel in accordance with requirements set forth in *Section — General Safety Practices*.
- Tilt bucket down to dump load.
- Fork mounted bucket weight must be included as part of total load being lifted.
- Do not use with mast carriage attachment.
- Do not use fork mounted bucket with attachments capable of rotating (i.e. side tilt and swing carriages) without disabling the rotation feature(s).

### **Equipment Damage Precautions**

- Except for lifting or dumping a load, the boom must be fully retracted for all bucket operations.
- Do not corner-load bucket. Distribute material evenly within the bucket. Capacity charts are for evenly distributed loads only.
- Do not use bucket as a lever to pry material. Excessive prying forces could damage bucket or machine structure.
- Do not attempt to load material which is hard or frozen. This could cause severe damage to coupler or machine structure.
- Do not use bucket for "back dragging." This could cause severe damage to coupler and retraction cables/chains.

### 5.10.14 Trash Hopper - Fork Mounted

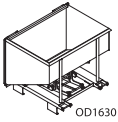

Use Appropriate Trash Hopper Capacity Chart.

To determine maximum capacity, refer to [Section — Telehandler/Attachment/Fork Capacity](#).

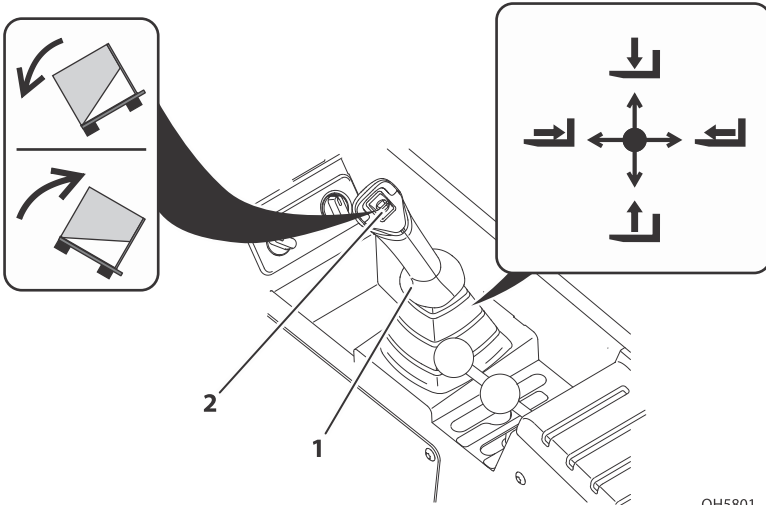

OH5801

Joystick **(1)** controls movement of the boom

Roller switch **(2)** controls trash hopper tilt.

- Press roller switch down to tilt up.
- Press roller switch up to tilt down.

#### Installation Procedure:

- Ensure carriage is properly installed. Refer to [Section — Attachment Installation](#).
- Secure the fork mounted trash hopper to the forks by sliding the fork mounted trash hopper onto the parent forks and install the retaining pin behind the vertical shank of the fork.

**Operation:**

- Raise or lower boom to appropriate height for loading material.
- Travel in accordance with requirements set forth in [Section — General Safety Practices](#).
- To release gate, tilt fork mounted trash hopper down approximately 10 degrees and engage bottom bumper on edge of dumpster. The gate will open allowing the contents to slide out.
- Tilt fork mounted trash hopper back to close and secure the gate.
- Do not use with mast carriage attachment.
- Do not use fork mounted trash hopper with attachments capable of rotating (i.e. side tilt carriages) without disabling the rotation feature(s).

**Equipment Damage Precautions**

- Except for lifting or dumping a load, the boom must be fully retracted for all fork mounted trash hopper operations.

## 5.10.15 Truss Boom

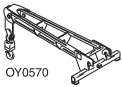

Use Appropriate Truss Boom Attachment Capacity Chart.

To determine maximum capacity, refer to [Section — Telehandler/Attachment/Fork Capacity](#).

**Suspend loads in accordance with requirements set forth in [Section — General Safety Practices](#).**

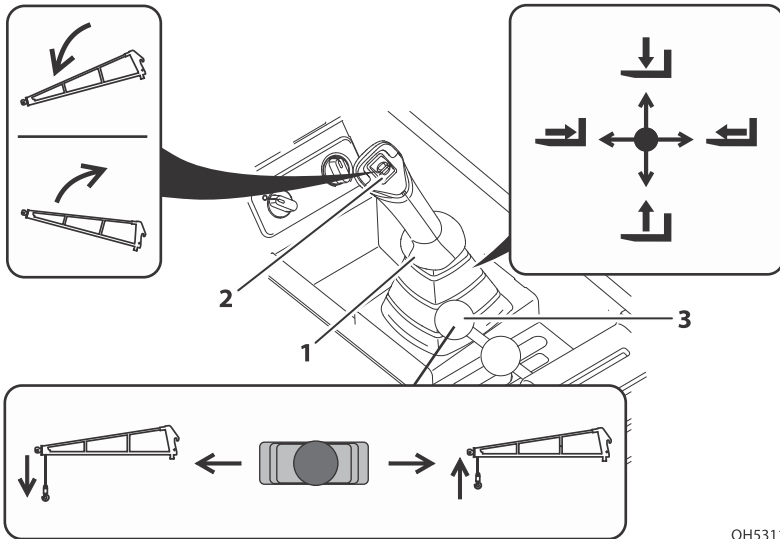

OH5311

Joystick **(1)** controls movement of the boom

Roller switch **(2)** controls truss boom tilt.

- Press roller switch down to tilt up.
- Press roller switch up to tilt down.

### **Winch Control (if equipped):**

Auxiliary hydraulic lever **(3)** controls the truss boom mounted winch.

- Press roller switch down to lower cable.
- Press roller switch up to raise cable.

### **Installation Procedures**

Refer to [Section — Attachment Installation](#).

# ⚠ WARNING

**CRUSH HAZARD.** Maintain a minimum of three wraps of wire rope on the cable drum at all times. Failure to comply could cause object or load to fall.

## Operation:

- Weight of rigging must be included as part of total load being lifted.

### 5.10.16 Adjustable Truss Boom - Fork Mounted

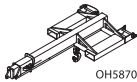

Use Appropriate Adjustable Truss Boom Attachment Capacity Chart.

To determine maximum capacity, refer to [Section — Telehandler/Attachment/Fork Capacity](#).

Suspend loads in accordance with requirements set forth in [Section — General Safety Practices](#).

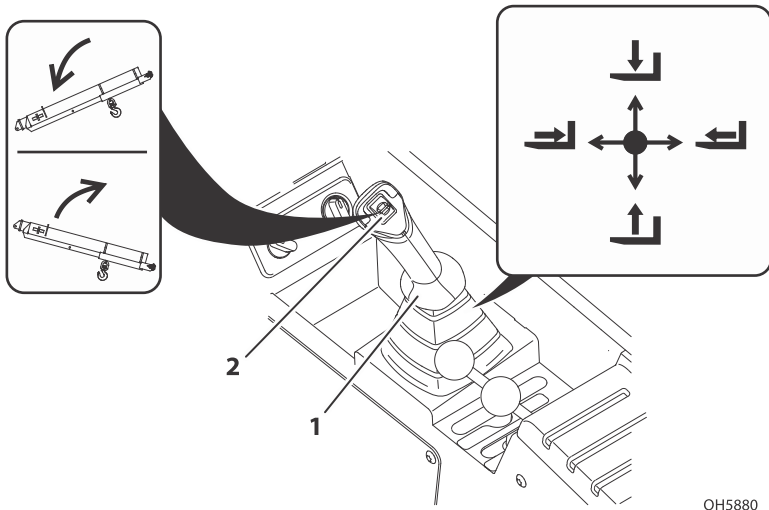

Joystick **(1)** controls movement of the boom.

Roller switch **(2)** controls adjustable truss boom tilt.

- Press roller switch down to tilt up.
- Press roller switch up to tilt down.

## Installation Procedures

- Ensure carriage is properly installed. Refer to [Section — Attachment Installation](#).

## Attachments

---

- Secure the adjustable truss boom to the forks by sliding the adjustable truss boom onto the parent forks and install the retaining pin behind the vertical shank of the fork.

# **WARNING**

**CRUSH HAZARD.** Ensure adjustable arm is properly secured using the retaining pin prior to lifting load. Failure to comply could cause object or load to fall.



**Operation:**

- Pallet or lumber forks of an appropriate load rating must be used. Do not use with cubing or block forks.
- Weight of rigging must be included as part of total load being lifted.
- Do not use with mast carriage attachment.
- Do not use adjustable truss boom with attachments capable of rotating (i.e. side tilt and swing carriages) without disabling the rotation feature(s).

### 5.10.17 Material Handling Arm

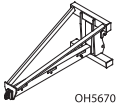

Use Appropriate Material Handling Arm Attachment Capacity Chart.

To determine maximum capacity, refer to [Section — Telehandler/Attachment/Fork Capacity](#).

Suspend loads in accordance with requirements set forth in [Section — General Safety Practices](#).

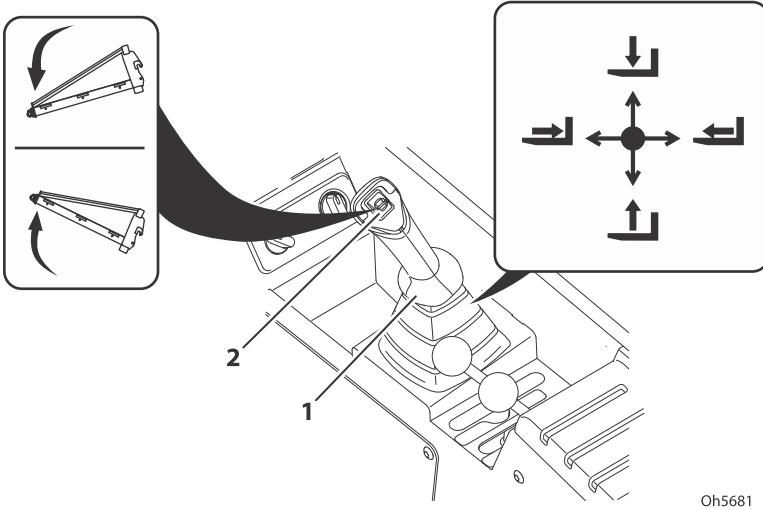

Joystick (1) controls movement of the boom.

Roller switch (2) controls material handling arm tilt.

- Press roller switch down to tilt up.
- Press roller switch up to tilt down.

#### Installation Procedures

- Refer to [Section — Attachment Installation](#).
- Secure adjustable arm in desired position using the retaining pin.

## **⚠ WARNING**

**CRUSH HAZARD.** Ensure adjustable arm is properly secured using the retaining pin prior to lifting load. Failure to comply could cause object or load to fall.

**Operation:**

- Weight of rigging must be included as part of total load being lifted.

**5.10.18 Personnel Work Platform - Fork Mounted**

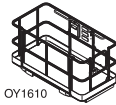

For fork mounted platforms utilized on machines built to the B56.6-2011 Standard or older, use Appropriate Carriage Attachment Capacity Chart.

For fork mounted platforms utilized on machines built to the B56.6-2016 Standard, use Fork Mounted Platform Attachment Capacity Chart.

To determine maximum capacity, refer to [Section — Telehandler/Attachment/Fork Capacity](#).

**The operator and personnel in platform must read and understand the separate personnel work platform manual prior to installing and using a platform.**

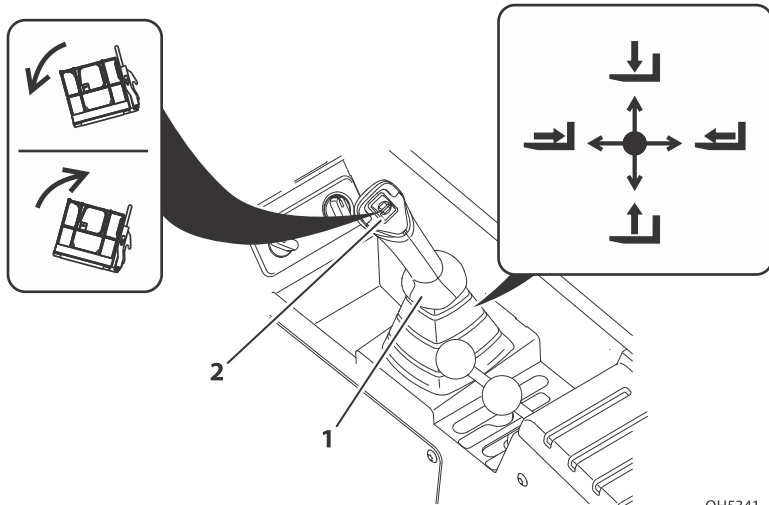

OH5341

Joystick **(1)** controls movement of the boom

Roller switch **(2)** controls platform tilt.

- Press roller switch down to tilt up.
- Press roller switch up to tilt down.

**Installation Procedure:**

- Ensure carriage is properly installed. Refer to [Section — Attachment Installation](#).
- Secure the fork mounted platform to the forks by sliding the fork mounted platform onto the parent forks and install the retaining pin behind the vertical shank of the fork.

### Preparation and Setup:

1. Ensure the telehandler is on a firm surface and is level.
2. Engage the park brake. Blocking the wheels is also recommended.
3. Level the platform, both side to side (frame level) and front to back (attachment tilt).
4. Keep area under platform free from personnel.
5. When personnel are on platform, the operator must remain seated in cab with personnel in direct line of sight.
6. **DO NOT** lift or carry persons in a bucket or on forks.

## **WARNING**

**FALL HAZARD.** Never tilt the platform forward, rearward, or level the machine when the platform is occupied.

### 5.10.19 Sweeper

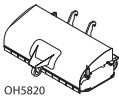

Use Sweeper Capacity Chart.

To determine maximum capacity, refer to [Section — Telehandler/Attachment/Fork Capacity](#).

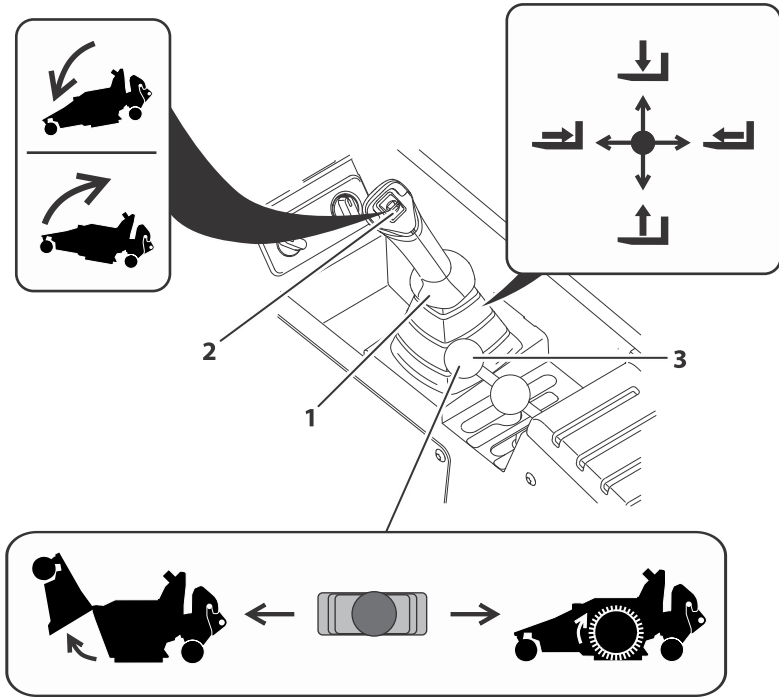

TH000213A

Joystick **(1)** controls movement of the boom

Roller switch **(2)** controls sweeper tilt.

- Press roller switch down to tilt up.
- Press roller switch up to tilt down.

#### Sweeper Control:

Roller Switch **(3)** controls the sweeper.

- Move lever left to open hopper.
- Move lever right to close hopper and engage sweeper brushes.

### Installation Procedure:

- Refer to [Section — Attachment Installation](#).

# WARNING

**CRUSH HAZARD.** Remove large objects in path of sweeper before operating. Failure to comply could cause object to be thrown by sweeper.

### Operation:

- Fully retract boom and lower until all four sweeper wheels are in contact with the ground.
- Operate roller switch **(3)** to engage sweeper brushes.
- Sweep a path less than the width of the sweeper.
- Travel in accordance with requirements set forth in [Section — General Safety Practices](#).
- To empty hopper, raise sweeper over desired dump area ensuring proper clearance. Operate roller switch **(3)** to open the hopper allowing the contents to slide out. Close the hopper after all contents are removed.

### Equipment Damage Precautions

- Except for emptying hopper, the boom must be fully retracted for all sweeper operations.
- Avoid excessive downward pressure on brushes when sweeping.
- Do not store sweeper with weight on brushes. Place on blocks or storage stands.

## 5.10.20 Boom Mounted Lifting Lug



Use Boom Mounted Lifting Lug Capacity Chart

To determine maximum capacity, refer to [Section — Telehandler/Attachment/Fork Capacity](#).

Suspend loads in accordance with requirements set forth in [Section — General Safety Practices](#).

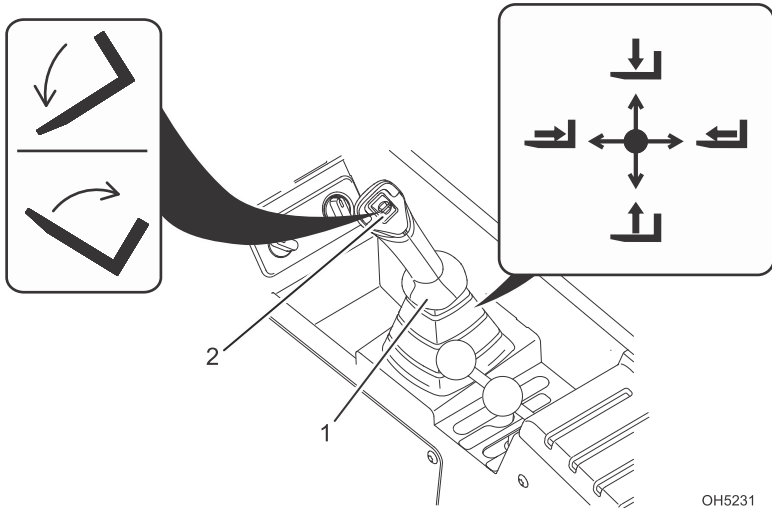

Joystick **(1)** controls movement of the boom.

Roller switch **(2)** controls carriage tilt.

- Press roller switch down to tilt up.
- Press roller switch up to tilt down.

# ⚠ WARNING

**TIP OVER HAZARD.** No load may be on attachment when lifting load with boom mounted lifting lug. Failure to comply could cause tip over.

### Operation:

- Weight of rigging must be included as part of total load being lifted.

**This Page is intentionally left blank**



# SECTION 6

## Emergency Procedures

---

### 6.1 TOWING A DISABLED PRODUCT

---

The following information assumes telehandler cannot be moved under its own power.

- Before moving the telehandler, read all of the following information to understand options available. Then select the appropriate method.
- Machine mounted retrieval devices provide suitable means to attach a tow rope, chain or tow bar only in the event the telehandler becomes stuck or disabled.
- Retrieval devices are not intended for on-road trailer towing applications.
- The steering system permits manual steering if engine or power assist feature fails; however, **steering will be slow and will require much greater force.**
- **DO NOT** attempt to tow a telehandler that is loaded or the boom/attachment is raised above 4 ft (1,2 m).

#### 6.1.1 Moving Short Distances

- If it is only necessary to move telehandler a short distance, less than 30 m (100 ft), it is permissible to use a vehicle of sufficient capacity to tow the unit with no previous preparation.

#### 6.1.2 Moving Longer Distance

- See Service Manual for information.
- Dependant on local regulations the appropriate machine Service Manual should be kept in the cab at all times.

**Contact the local dealer for specific instructions if neither of these methods are applicable.**

### 6.2 EMERGENCY LOWERING OF BOOM

---

In the event of total loss of engine power or hydraulic pump failure with an elevated load, the situation must be properly evaluated and dealt with on an individual basis. **Contact the local dealer for specific instructions.**

Secure the telehandler using the following procedures:

1. If equipped with platform attachment, rescue platform occupants.
2. Clear the area around telehandler of all personnel.
3. Apply the parking brake. Place the transmission in "NEUTRAL".

4. Block all four wheels.
5. Section off a large area under the boom to restrict any personnel from entering this area.
6. See Service Manual for information.

### 6.3 EMERGENCY EXIT FROM ENCLOSED CAB

---

#### 6.3.1 Fixed Window (if equipped)

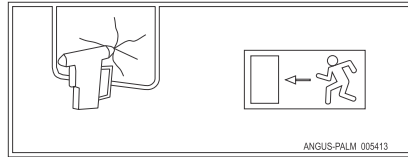

OWO740

- In an emergency, an escape hammer located directly below the rear window in an enclosed cab can be used to exit the telehandler.

#### 6.3.2 Latch Window (if equipped)

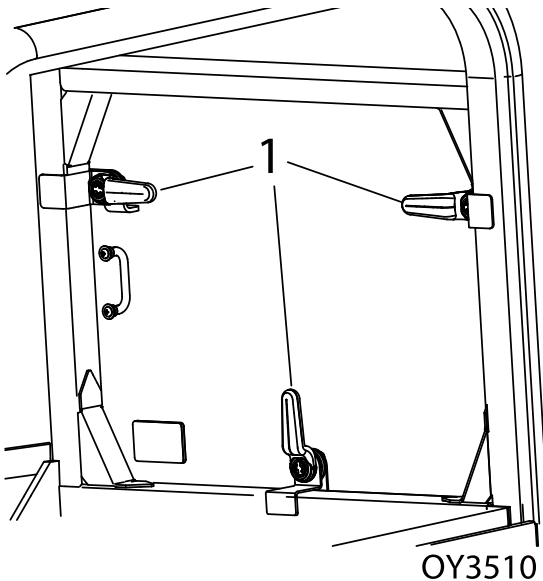

OY3510

- In an emergency, rear window can be removed to exit the telehandler by releasing hand latches (1).

# SECTION 7

## Lubrication and Maintenance

---

### 7.1 INTRODUCTION

---

This section is intended as information to assist the operator to perform maintenance tasks only. Service product in accordance with maintenance schedule on the following pages.

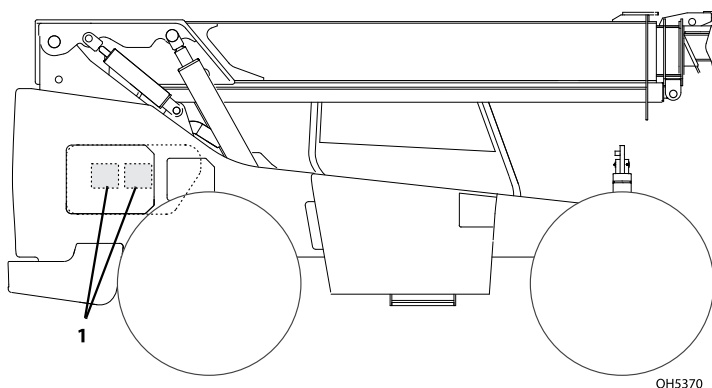

The Lubrication and Maintenance decals (1) contain instructions that must be followed to keep this product in good operating condition. The Operation & Safety Manual and Service Manual contain more detailed service information with specific instructions.

#### 7.1.1 Clothing and Safety Gear

- Wear all the protective clothing and personal safety devices issued to you or called for by job conditions.
- DO NOT wear loose clothing or jewelry that can get caught on controls or moving parts.

## 7.2 GENERAL MAINTENANCE INSTRUCTIONS

---

**Prior to performing any service or maintenance on the telehandler, follow the *Shut-Down Procedure* unless otherwise instructed. Ensure telehandler is level, for proper fluid readings.**

- Clean lubrication fittings before lubricating.
- After greasing telehandler, cycle all functions several times to distribute lubricants. Perform this maintenance procedure without attachment installed.
- Apply a light coating of engine oil to all linkage pivot points.
- Intervals shown are for normal usage and conditions. Adjust intervals for abnormal usage and conditions.
- Check all lubricant levels when lubricant is cool, with the exception of the transmission fluid. For ease of filling hydraulic reservoir, use a funnel with a hose or flexible tube for best results.

### **WARNING**

**CUT/CRUSH/BURN HAZARD.** Do not perform service or maintenance on the machine with engine running with the exception of transmission fluid level check.

## 7.3 MAINTENANCE SCHEDULES

---

**Note:** If hour and year intervals are listed, perform maintenance at interval that occurs first.

### 7.3.1 Every 10 Hours



Check Fuel Level



Check Tire Condition and Pressure



Check Brake Fluid Level



Check Engine Oil Level



Check Hydraulic Oil Level



Check Transmission Oil Level



Check DEF Level (if equipped for ULS/85 or 110HP)



Check Air Cleaner



Drain Fuel/Water Separator



Check Engine Coolant Level



Additional Checks (see [Section — Additional Checks](#))

### 7.3.2 First 50 Hours



Check Wheel Lug Nut Torque



Check Boom Chain Tension

### 7.3.3 Every 50 Hours



Lubrication Schedule



Check Washer Fluid

### 7.3.4 First 250 Hours



Change Axle Oil



Change Wheel End Oil



Change Transmission  
Fluid and Filter

### 7.3.5 Every 250 Hours



Lubrication Schedule



Check Boom Chains



Check Boom Wear Pads



Check Wheel End Oil  
Level



Check Axle Oil Level

### 7.3.6 First 500 Hours



Change Engine Oil and Filter (if equipped for ULS)

### 7.3.7 Every 500 Hours



Check Battery



Check Fan Belt



Check Wheel Lug Nut Torque



Change Engine Oil and Filter (if equipped for LS)

### 7.3.8 Every 750 Hours



Change Hydraulic Tank Breather (if equipped for ULS)



Change Hydraulic Filters

### 7.3.9 Every 1000 Hours



OC1010

Lubrication Schedule



OC1000

Check Boom Chain Tension



OC1200

Check Air Intake System



OC1210

Check Park Brake



OH5860

Grease Boom Chains



OC1040

Change Axle Oil



OC1050

Change Wheel End Oil



OC1070

Change Transmission Fluid and Filter



OC1170

Change Engine Oil and Filter (if equipped for ULS, see note)



OC1220

Change Fuel Filters

**Note:** If using fully synthetic oil, metal engine oil filter and fuel consumption is less than 11.4 liter per hour (3 gallon per hour), oil change intervals are 1,000 hours or 1 year. If any of the following are present, conventional oil, plastic engine oil filter or fuel consumption is greater than 11.4 liter per hour (3 gallon per hour), oil change intervals are 500 hours or 6 months.

### 7.3.10 Every 1500 Hours



OC1230

Change Hydraulic Fluid and Filters



### 7.3.11 Every 2000 Hours or 2 Years



Clean Engine Coolant (if equipped for ULS) and Clean Engine Coolant Strainer (if equipped for ULS/85 or 110HP)



Change DEF Tank Filter (if equipped for ULS/85 or 110HP)



Change Engine Coolant (if equipped for LS)

### 7.3.12 Every 4000 Hours or 3 Years



Change DEF Pump Filter (if equipped for ULS/85 or 110HP)

### 7.3.13 Every 5000 Hours or 4 Years



Engine Valve Lash Adjustment

## 7.4 LUBRICATION SCHEDULES

### 7.4.1 50 Hour Lubrication Schedule

6036 & 6042

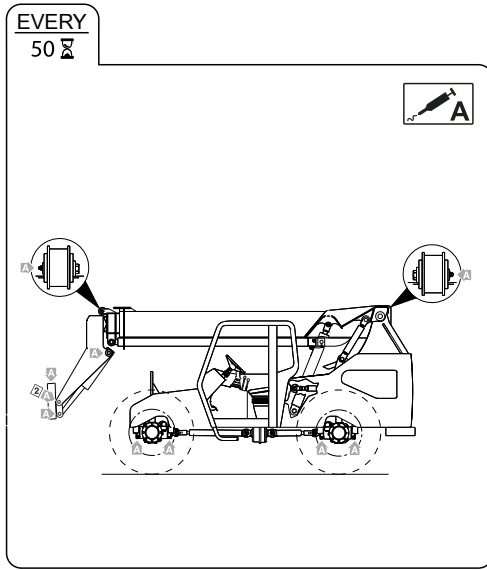

**8042 & 10042**

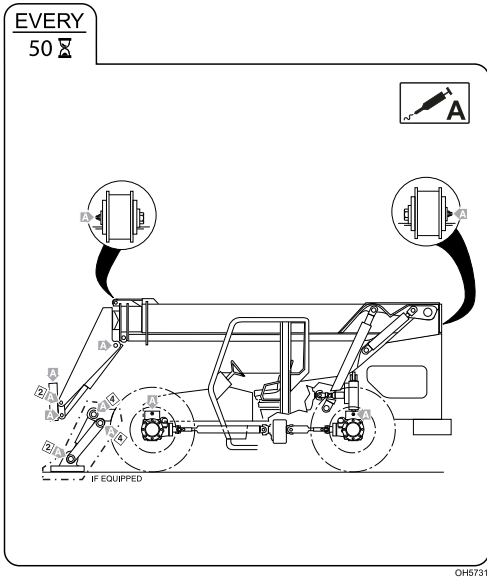

**10054 & 12054**

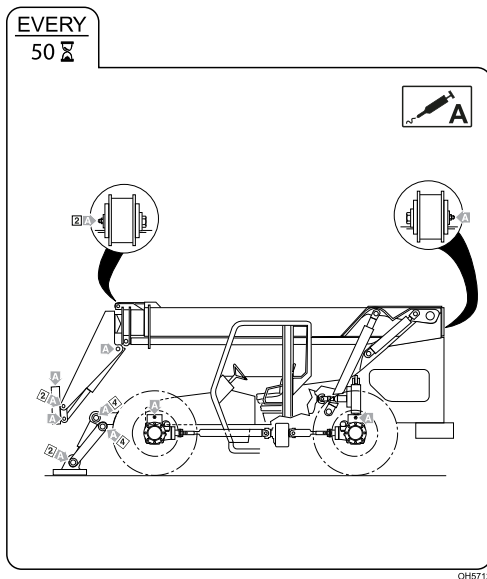

### 7.4.2 250 Hour Lubrication Schedule

6036 & 6042

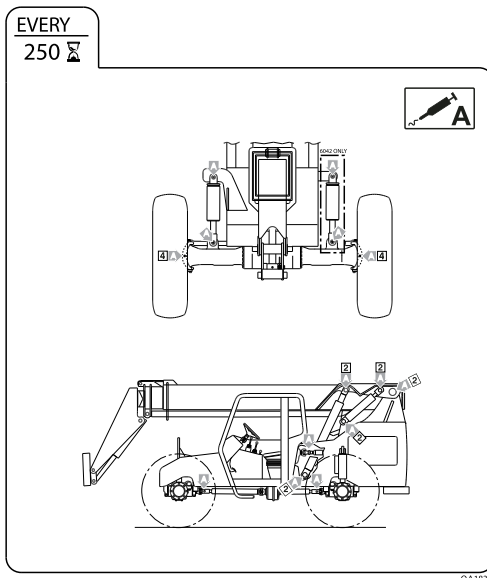

8042, 10042, 10054 & 12054

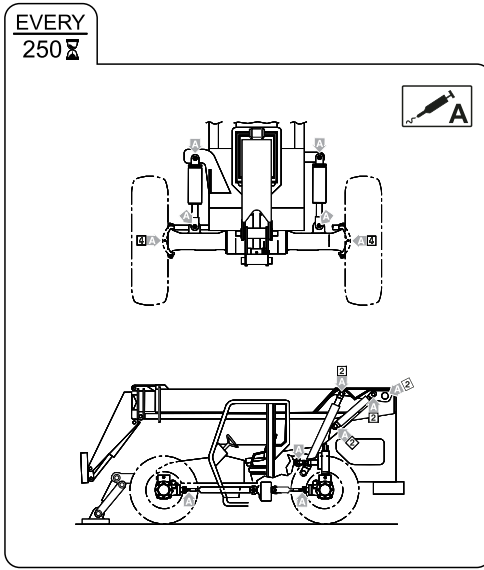

### 7.4.3 1000 Hour Lubrication Schedule

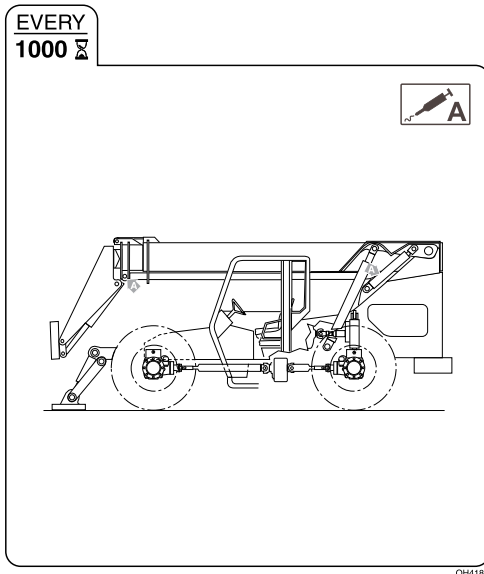

## 7.5 OPERATOR MAINTENANCE INSTRUCTIONS

---

### 7.5.1 Fuel System

#### Fuel Level Check

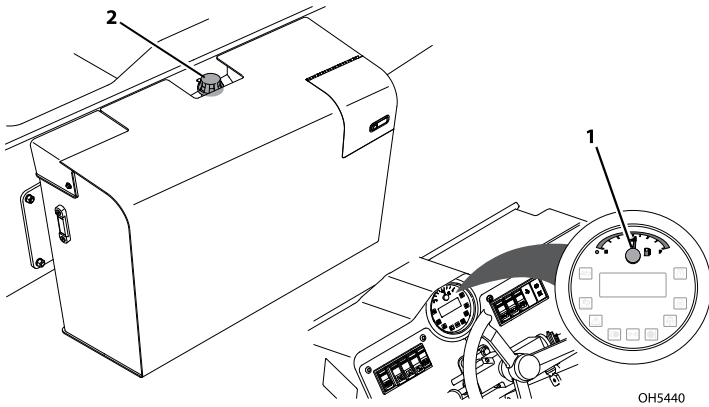

1. Check Fuel Gauge **(1)** located in right side of Instrument Panel in cab.
2. If fuel is low, proceed to fuel source and perform *Shut-Down Procedure*.
3. Turn fuel tank cap **(2)** to remove from filler neck.
4. Add fuel as needed.
5. Replace fuel tank cap.

**Note:** Replenish diesel fuel at end of each work shift to minimize condensation.

## NOTICE

**EQUIPMENT DAMAGE.** Do not allow machine to run out of fuel during operation. See Engine Operation & Maintenance Manual for details prior to servicing.

## Drain Fuel/Water Separator

10  CW0970  CW1000

IF EQUIPPED FOR ULS

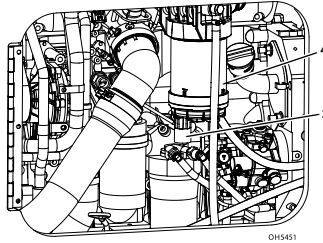

IF EQUIPPED FOR LS

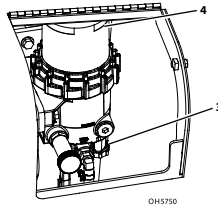

1. Perform *Shut-Down Procedure*.
2. Open engine cover.
3. Loosen drain cock (3) on underside of fuel filter (4) and allow all water to drain into a glass until clear fuel is visible.
4. Tighten drain cock.
5. Close and secure engine cover.

### 7.5.2 Diesel Exhaust Fluid (DEF) System (if equipped for ULS/85 or 110HP)

#### Diesel Emission Fluid (DEF) Level Check

10   
OW0970

  
OD1350

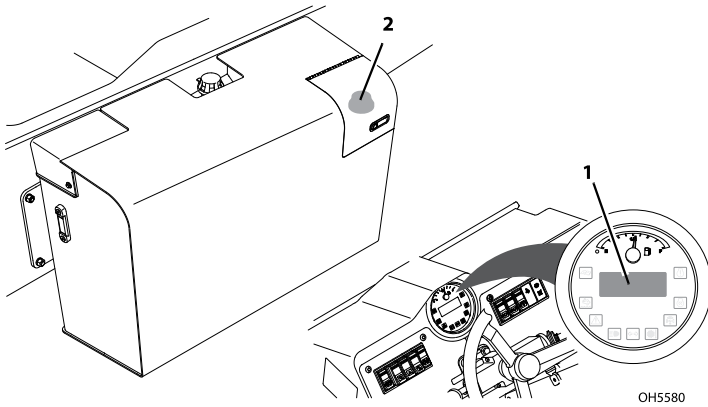

1. Check Diesel Emission Fluid (DEF) Gauge (1) located in right side of Instrument Panel in cab.
2. If DEF is low, proceed to DEF source and perform *Shut-Down Procedure*.
3. Turn DEF tank cap (2) to remove.
4. Add DEF as needed.
5. Replace DEF tank cap.

**Note:** If DEF level becomes too low, system derate and/or idle-lock may occur.

## NOTICE

**EQUIPMENT DAMAGE.** Do not allow machine to run out of Diesel Emission Fluid (DEF) during operation. See the Engine Operation & Maintenance Manual for details prior to servicing.

### 7.5.3 Engine Oil

#### Engine Oil Level Check

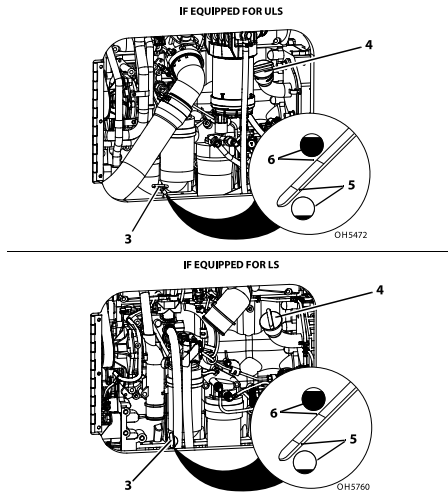

1. Perform *Shut-Down Procedure*.

**Note:** Allow machine to be shut down for 10 to 15 minutes before removing dipstick to check engine oil level.

2. Open engine cover.
3. Remove dipstick (3) and check oil mark. Oil should be between full (6) and add (5) marks of dipstick.
4. If oil is low, remove oil fill cap (4) and add oil to bring oil up to full mark in crosshatch area.
5. Replace oil fill cap.
6. Close and secure engine cover.

## 7.5.4 Air Intake System

### Air Cleaner Check



10   
OW0970

  
OW1010

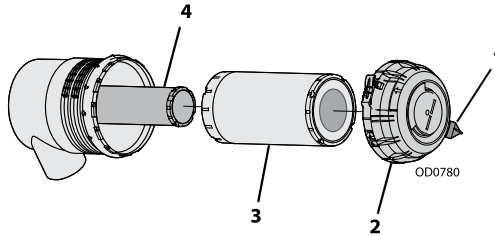

1. Perform *Shut-Down Procedure*.
2. Open engine cover.
3. Remove dust from vacuator valve (1) by squeezing bottom of valve to allow loose particles to fall out.
4. Close and secure engine cover.

## NOTICE

**EQUIPMENT DAMAGE.** Only remove air cleaner cover to service elements. Excessive access to check elements can lead to premature element and/or engine failure.

### Restriction Fault Code

1. Fault Code 107:15 indicates restricted air filter.
2. Primary element (3) must be replaced.

### Element Change

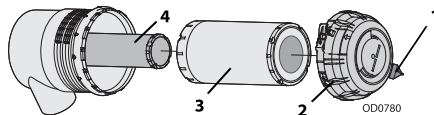

**Note:** Change elements as air cleaner restriction indicator indicates or every two years. Use the interval that occurs first.

1. Perform *Shut-Down Procedure*.
2. Open engine cover.

3. Unlock air cleaner cover **(2)** and remove from air cleaner.
4. Remove outer primary element **(3)**. Inspect element for damage then discard.
5. Thoroughly clean interior of air cleaner canister and vacuator valve **(1)**.
6. Replace inner safety element **(4)** every third primary element change or if primary element was found to be damaged. If replacing inner safety element at this time, carefully slide element out and replace with new element.
7. Slide new primary element over inner safety element making sure sealing edge is flush with base of air cleaner.
8. Position air cleaner cover in place and lock into position.
9. Close and secure engine cover.

**Note:** Elements should never be washed or reused. Always install new elements.

### ***NOTICE***

**EQUIPMENT DAMAGE.** Primary and safety elements are required to be replaced if used in an application longer than two years regardless of hours of operation.

# SECTION 8

## Additional Checks

### 8.1 STABIL-TRAK (6042, 8042, 10042, 10054 & 12054)

#### Stabil-Trak Indicator Test

10



OW0970

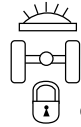

OH4340

Stabil-Trak system operates in three modes. In locked mode the indicator light illuminates. If indicator does not illuminate the test was not performed properly or Stabil-Trak system is not functioning correctly and the test should be stopped immediately. To check the indicator, perform the following:

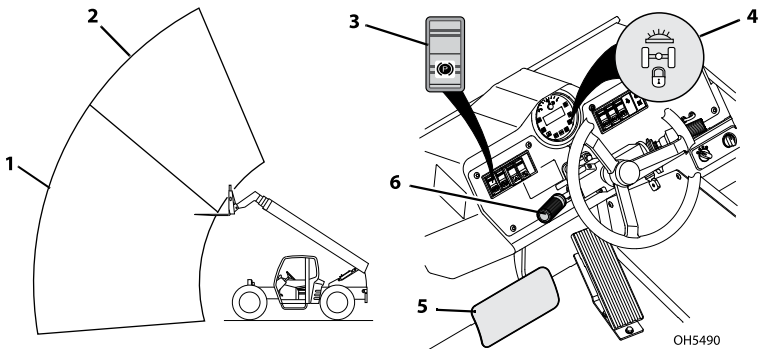

1. Test Stabil-Trak system on a level surface and boom fully retracted, no load.
2. Shift transmission to neutral (6).
3. Raise boom above 40° (2). Stabil-Trak system locked mode will be activated and indicator (4) will illuminate.
4. Lower boom below 40° (1).
5. Depress service brake pedal (5) and shift transmission into forward.
6. Raise the boom above 40°. Stabil-Trak system locked mode will be activated and indicator will illuminate.
7. Lower boom below 40°.
8. Engage park brake switch (3).
9. Release service brake pedal.

## Additional Checks

10. Raise the boom above 40°. Stabil-Trak system locked mode will be activated and indicator will illuminate.
11. Lower boom below 40°.
12. Shift transmission to neutral.

## 8.2 BOOM/OUTRIGGER INTERLOCK (10054 & 12054)

### Boom/Outrigger Interlock System Test

# 10

## OW0970

Boom/Outrigger Interlock system operates in two modes. In extend interlock mode, with outriggers raised, a sensor in the boom will stop boom from extending past a point between the "E" and "F" extension indicators. In outrigger interlock mode, with outriggers lowered, boom will extend fully and Stabil-Trak indicator will illuminate. To check the sensor and indicator, perform the following:

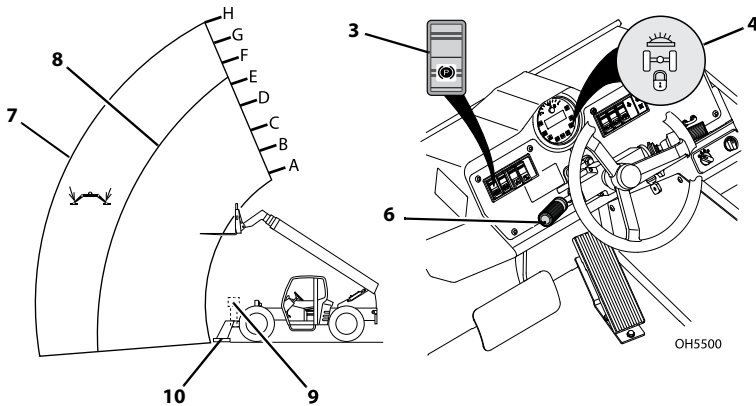

1. Test Boom/Outrigger Interlock system on a level surface and boom horizontal, no load.
2. Shift transmission to neutral (6) and engage park brake (3).
3. Raise outriggers (9).
4. Extend boom until it stops. Boom will stop at a point (8) between the "E" and "F" extension indicators.

5. Retract boom.
6. Lower outriggers (10) on firm terrain.
7. Extend boom (7) until it stops. Boom will fully extend and Stabil-Trak indicator (4) will illuminate.

## 8.3 REVERSE SENSING SYSTEM (IF EQUIPPED)

### Reverse Sensing System Check



Reverse Sensing System provides audible indication of objects to rear of unit while in reverse gear.

1. Clear all people and/or obstacles behind machine before performing Reverse Sensing System check.
2. Start machine and depress and hold brake. Place machine in reverse gear.
3. Verify alarm sounds upon system start up.

**Note:** Reverse Sensing System detects objects of size more than 36 square inches (232.25 square centimeters) area and is functional when machine is moving in reverse direction.

**Note:** The use of a construction cone or similar object must be used to test the Reverse Sensing System.

# WARNING

**CRUSH HAZARD.** Do not use a person to test the reverse sensing system.

4. Verify operation with no objects in detection zone. No audible alarm.
5. Verify operation when object is in range of approximately 9 to 15 ft (2.7 to 4.5 m). Produces pulsing audible alarm at a frequency of one per second (1 Hz).
6. Verify operation when object is in range of approximately 7 to 9 ft (2.1 to 2.7 m). Produces pulsing audible alarm. Produces pulsing audible alarm at a frequency of two per second (2 Hz).
7. Verify operation when object is range of approximately 5 to 7 ft (1.5 to 2.1 m). Produces pulsing audible alarm at a frequency of four per second (4 Hz).
8. Verify operation when object is under approximately 5 ft (1.5 m) from machine. Produces pulsing audible alarm at a frequency of eight per second (8 Hz).

## 8.4 AIR SHUTOFF VALVE (ASOV) (IF EQUIPPED)

### Air Shutoff Valve Test



Air Shutoff Valve (ASOV) is an overspeed protection device mounted to the engine's air intake system. When the valve is actuated, it obstructs airflow intake and stops the engine. Weekly tests are recommended to ensure the valve remains in good working condition.

1. Start the engine, running at idle.
2. Open the red switch guard of ASOV test switch, then activate toggle to test mode (see [Section — Controls](#)).
3. Rev the engine in neutral until the valve actuates at the test RPM of 1500. Once valve actuates, engine will stop.
4. Turn ignition to OFF.
5. Visually inspect valve to ensure it appears in good condition.
6. Reset valve by rotating valve handle to the Open position.

**Note:** The handle cannot be turned unless the machine is off. Ensure the ignition is moved to the OFF position.

## WARNING

Do not use ASOV as an alternative to shutting down machine properly.

**This Page is intentionally left blank**



# SECTION 9

## Specifications

### 9.1 PRODUCT SPECIFICATIONS

#### 9.1.1 Fluids

If Equipped for ULS

Compartment or System	Type and Classification	Viscosities	Ambient Temperature Range			
			°F		°C	
			Min	Max	Min	Max
Engine Crankcase	API CJ-4 Plus CES-20081 Fully Synthetic*	SAE 5W-40	-12	114	-24	45
		SAE 15W-40	15	114	-10	45
		SAE 10W-30	10	104	-12	40
		SAE 5W-30	-12	104	-24	40
		SAE 0W-30	-40	32	-40	0
Transmission and Transfer Case	MobilFluid 424 Spirax S4 TXM	10W-30	-4	120	-20	49
	ZF TE-ML-03	75W-80	-20	15	-29	-10
Axle Differential and Wheel End	API GL5 with LS Additives	75W-90 LS	-20	114	-29	45
		80W-90 LS or 85W-90 LS	-4	114	-20	45
Hydraulic System	MobilFluid 424 Spirax S4 TXM	10W-30	15	120	-10	49
	Exxon Univis HVI		-20	120	-29	49
Boom Wear Pad Grease	Mystik Tetrimoly	NLGI Grade 2	-4	104	-20	40
Grease Fittings	Extreme Pressure Grease with Moly Additive or NLGI Grade 3 EP with Moly Additive	NLGI Grade 2 EP	5	114	-15	45
Boom Chain Lubricant	Gear Oil	80W-90	-20	114	-29	45
Engine Coolant	Ethylene Glycol and Water	50/50 Mix	Standard			
		60/40 Mix	Cold Weather			

## Specifications

Compartment or System	Type and Classification	Viscosities	Ambient Temperature Range			
			°F		°C	
			Min	Max	Min	Max
Fuel	EN590 ASTM D 975 Grade 1-D ASTM D 975 Grade 2-D (Maximum B5 Biodiesel)	Ultra Low Sulfur (S < 15 mg/kg)				
Diesel Exhaust Fluid (DEF) (85 or 110HP)	ISO22241-1	32.5% Urea				
Brake Fluid	Mobil ATF-D/M					
Air Conditioning	Refrigerant R-134a	Tetrafluoroethane				

\*See Note on page 7-6 for details.

### 9.1.2 Capacities

<b>Engine Crankcase Oil</b>	
Capacity with Filter Change	12.7 qt (12 L)
<b>Fuel Tank</b>	
Capacity	35 gal (133 L)
<b>DEF Tank (if equipped for ULS/85 or 110HP)</b>	
Capacity	5 gal (19 L)
<b>Cooling System</b>	
System Capacity	5 gal (19 L)
<b>Hydraulic System</b>	
System Capacity	
6036 & 6042	45 gal (170 L)
8042	46 gal (174 L)
10042 & 10054	52 gal (197 L)
12054	50 gal (188 L)
Reservoir Capacity to Full Mark	20.2 gal (76,5 L)
<b>Transmission</b>	
Capacity with Filter Change	12.5 qt (11,8 L)

### 9.1.3 Axles

Differential Housing Capacity	
6036 & 6042	6.6 qt (6,2 L)
8042	
Front Axle	7.9 qt (7,5 L)
Rear Axle	8.2 qt (7,8 L)
10042 & 10054	
Front Axle	12.7 qt (12,0 L)
Rear Axle	7.9 qt (7,5 L)
12054	
Front Axle	12.7 qt (12,0 L)
Rear Axle	13.4 qt (12,7 L)
Wheel End Capacity	
6036 & 6042	1.9 qt (1,8 L)
8042	2.1 qt (2,0 L)
10042, 10054 & 12054	
Front Axle	1.9 qt (1,8 L)
Rear Axle	2.1 qt (2,0 L)

### 9.1.4 Brake System

Capacity	1.1 qt (1,0 L)
----------	----------------

### 9.1.5 Window Washer Bottle (if equipped)

Capacity	2.2 qt (2,1 L)
----------	----------------

### 9.1.6 Air Conditioning System (if equipped)

Capacity	1.9 lb (0.86 kg)
----------	------------------

### 9.1.7 Tires

<b>6036</b>	
13.00 x 24, G-2/L-2 Bias Ply Traction - 12 Ply	

## Specifications

13.00 x 24, Solid, Non-Marking	
Pneumatic	70 psi (4,8 bar)
Foam	Approx 542 lb (246 kg)
370/75-28, 14 Ply	
Pneumatic	76 psi (5,2 bar)
Pneumatic, Non-Marking	73 psi (5,0 bar)
Foam	Approx 464 lb (210 kg)
Foam, Non-Marking	Approx 464 lb (210 kg)
18 x 625, 16 Ply	
Pneumatic	76 psi (5,2 bar)
<b>6042</b>	
13.00 x 24, G-2/L-2 Bias Ply Traction - 12 Ply	
13.00 x 24, Solid, Non-Marking	
Pneumatic	70 psi (4,8 bar)
Foam	Approx 542 lb (246 kg)
Foam Rock	Approx 542 lb (246 kg)
370/75-28, 14 Ply	
Pneumatic	76 psi (5,2 bar)
Pneumatic, Non-Marking	73 psi (5,0 bar)
Foam	Approx 464 lb (210 kg)
Foam, Non-Marking	Approx 464 lb (210 kg)
18 x 625, 16 Ply	
Pneumatic	76 psi (5,2 bar)
<b>8042</b>	
15.50 x 25, G-2/L-2 Bias Ply Traction - 12 Ply	
13.00 x 24, Solid, Non-Marking	
Pneumatic	70 psi (4,8 bar)
Foam	Approx 600 lb (272 kg)
370/75-28, 14 Ply	
Pneumatic	76 psi (5,2 bar)

Pneumatic, Non-Marking	73 psi (5,0 bar)
Foam	Approx 464 lb (210 kg)
Foam, Non-Marking	Approx 464 lb (210 kg)
18 x 625, 16 Ply	
Pneumatic	76 psi (5,2 bar)
<b>10042 &amp; 10054</b>	
17.50 x 25, G-2/L-2 Bias Ply Traction - 12 Ply	
14.00 x 24, Solid, Non-Marking	
Pneumatic	65 psi (4,5 bar)
Foam	Approx 785 lb (356 kg)
400/75-28, 16 Ply	
Pneumatic	76 psi (5,2 bar)
Pneumatic, Non-Marking	76 psi (5,2 bar)
Foam	Approx 570 lb (259 kg)
Foam, Non-Marking	Approx 570 lb (259 kg)
18 x 625, 16 Ply	
Pneumatic	100 psi (6,9 bar)
<b>12054</b>	
17.50 x 25, G-2/L-2 Bias Ply Traction - 12 Ply	
14.00 x 24, Solid, Non-Marking	
Pneumatic	65 psi (4,5 bar)
Foam	Approx 785 lb (356 kg)
400/75-28, 16 Ply	
Pneumatic	76 psi (5,2 bar)
Pneumatic, Non-Marking	76 psi (5,2 bar)
Foam	Approx 570 lb (259 kg)
Foam, Non-Marking	Approx 570 lb (259 kg)
18 x 625, 16 Ply	
Pneumatic	100 psi (6,9 bar)

## Specifications

Wheel Lug Nut	
Torque	350–400 lb-ft (474–542 Nm)

### 9.1.8 Performance

Maximum Lift Capacity	
6036 & 6042	6,000 lb (2 722 kg)
8042	8,000 lb (3 629 kg)
10042 & 10054	10,000 lb (4 536 kg)
12054	12,000 lb (5 443 kg)
Maximum Lift Height	
6036	36 ft (11,0 m)
6042, 8042 & 10042	42 ft (12,8 m)
10054 & 12054	53.2 ft (16,2 m)
Capacity at Maximum Height	
6036, 6042, 8042 & 10042	6,000 lb (2 722 kg)
10054	4,000 lb (1 814 kg)
12054	5,000 lb (2 268 kg)
Maximum Forward Reach	
6036	22.3 ft (6,8 m)
6042	27.9 ft (8,5 m)
8042	26.6 ft (8,1 m)
10042	26.5 ft (8,1 m)
10054 & 12054	
Outriggers Engaged.	38.8 ft (11,8 m)
Outriggers Not Engaged	26.5 ft (8,1 m)
Capacity at Maximum Forward Reach	
6036	1,800 lb (816 kg)
6042	1,400 lb (635 kg)
8042	2,200 lb (998 kg)
10042	
Outriggers Engaged	6,000 lb (2 722 kg)

Outriggers Not Engaged	2,000 lb (907 kg)
10054	
Outriggers Engaged	3,000 lb (1 361 kg)
Outriggers Not Engaged	1,400 lb (635 kg)
12054	
Outriggers Engaged	3,500 lb (1 588 kg)
Outriggers Not Engaged	0 lb (0 kg)
<b>Reach at Maximum Height</b>	
6036	5.1 ft (1,6 m)
6042	6.3 ft (1,9 m)
8042	4.8 ft (1,5 m)
10042	4.7 ft (1,4 m)
10054 & 12054	9.4 ft (2,9 m)
<b>Auxiliary Hydraulic Circuit Max Flow</b>	25 gpm (94,6 lpm)
<b>Maximum Travel Speed</b>	
6036	21.4 mph (34 kph)
6042	20.1 mph (32 kph)
8042	19.9 mph (32 kph)
10042 & 10054	20.5 mph (33 kph)
12054	
ULS & LS Engines	18.2 mph (29.3 kph)
74 HP Engine	16.5 mph (26.5 kph)
<b>Hitch Capacity (no load on attachment)</b>	
6036 & 6042	6,000 lb (2 722 kg)
8042	8,000 lb (3 629 kg)
10042 & 10054	10,000 lb (4 536 kg)
12054	12,000 lb (5 443 kg)
<b>Frame Leveling</b>	10 degrees
Gradeability	24 degrees (45%)
Side Slope	5 degrees (8.75%)

## Specifications

### 9.1.9 Dimensions

<b>Overall Height</b>	
6036	100 in (2 540 mm)
6042	102 in (2 591 mm)
8042	99.4 in (2 525 mm)
10042, 10054 & 12054	100.1 in (2 543 mm)
<b>Overall Width</b>	
6036 & 6042	99 in (2 515 mm)
8042	99.2 in (2 520 mm)
10042, 10054 & 12054	
Outriggers Engaged	102 in (2 591 mm)
Outriggers Not Engaged	156.8 in (3 983 mm)
<b>Track Width</b>	
6036 & 6042	85 in (2 159 mm)
8042	84 in (2 134 mm)
10042, 10054 & 12054	84.2 in (2 139 mm)
<b>Wheelbase</b>	
6036 & 6042	113 in (2 870 mm)
8042, 10042, 10054 & 12054	119.5 in (3 035 mm)
<b>Overall Length (no attachment)</b>	
6036	224 in (5 690 mm)
6042	234 in (5 944 mm)
8042	228 in (5 791 mm)
10042	248 in (6 299 mm)
10054 & 12054	252 in (6 401 mm)
<b>Ground Clearance</b>	
6036 & 6042	14.5 in (368 mm)
8042	17.5 in (445 mm)
10042, 10054 & 12054	18 in (457 mm)
<b>Turning Radius (Curb to Curb)</b>	
6036, 10054 & 12054	165 in (4 191 mm)



6042	168 in (4 267 mm)
8042	156 in (3 962 mm)
10042	170 in (4 318 mm)
<b>Turning Radius (Clearance)</b>	
6036 & 6042	151 in (3 835 mm)
8042	156 in (3 962 mm)
10042	176 in (4 470 mm)
10054 & 12054	174 in (4 420 mm)
<b>Maximum Operating Weight (no attachment)</b>	
6036	23,550 lb (10 682 kg)
6042	27,400 lb (12 428 kg)
8042	28,500 lb (12 927 kg)
10042	30,150 lb (13 676 kg)
10054	31,500 lb (14 288 kg)
12054	33,100 lb (15 014 kg)
Distribution of Maximum Operating Weight (no attachment, boom level and fully retracted)	
<b>Front Axle</b>	
6036.	7,530 lb (3 416 kg)
6042	8,477 lb (3 845 kg)
8042	8,674 lb (3 935 kg)
10042	10,300 lb (4 672 kg)
10054	10,534 lb (4 778 kg)
12054	11,300 lb (5 126 kg)
<b>Rear Axle</b>	
6036	16,020 lb (7 267 kg)
6042	18,923 lb (8 583 kg)
8042	19,826 lb (8 993 kg)
10042	19,850 lb (9 004 kg)
10054	20,966 lb (9 510 kg)
12054	21,800 lb (9 888 kg)

## Specifications

<b>Maximum Ground Bearing Pressure</b>	
6036	
13.00 x 24	
Air Filled	136 lb/in <sup>2</sup> (9,6 kg/cm <sup>2</sup> )
Foam Filled	177 lb/in <sup>2</sup> (12,4 kg/cm <sup>2</sup> )
370/75-28	
Air Filled	110 lb/in <sup>2</sup> (7,7 kg/cm <sup>2</sup> )
Foam Filled	144 lb/in <sup>2</sup> (10,1 kg/cm <sup>2</sup> )
315/95-28	
Solid	168 lb/in <sup>2</sup> (11,8 kg/cm <sup>2</sup> )
18 x 625, 16 Ply	
Pneumatic	Not Available at Publication
6042	
13.00 x 24	
Air Filled	139 lb/in <sup>2</sup> (9,8 kg/cm <sup>2</sup> )
Foam Filled	181 lb/in <sup>2</sup> (12,7 kg/cm <sup>2</sup> )
Solid	187 lb/in <sup>2</sup> (13,1 kg/cm <sup>2</sup> )
370/75-28	
Air Filled	113 lb/in <sup>2</sup> (7,9 kg/cm <sup>2</sup> )
Foam Filled	148 lb/in <sup>2</sup> (10,4 kg/cm <sup>2</sup> )
315/95-28	
Solid	172 lb/in <sup>2</sup> (12,1 kg/cm <sup>2</sup> )
18 x 625, 16 Ply	
Pneumatic	Not Available at Publication
8042	
15.50 x 25	
Air Filled	149 lb/in <sup>2</sup> (10,5 kg/cm <sup>2</sup> )
Foam Filled	190 lb/in <sup>2</sup> (13,4 kg/cm <sup>2</sup> )
370/75-28	
Air Filled	116 lb/in <sup>2</sup> (8,2 kg/cm <sup>2</sup> )

Foam Filled	150 lb/in <sup>2</sup> (10,5 kg/cm <sup>2</sup> )
315/95-28	
Solid	187 lb/in <sup>2</sup> (13,1 kg/cm <sup>2</sup> )
18 x 625, 16 Ply	
Pneumatic	Not Available at Publication
10042	
Outriggers	98 lb/in <sup>2</sup> (6,9 kg/cm <sup>2</sup> )
Tires	
17.50 x 25	
Air Filled	104 lb/in <sup>2</sup> (7,3 kg/cm <sup>2</sup> )
Foam Filled	135 lb/in <sup>2</sup> (9,5 kg/cm <sup>2</sup> )
400/75-28	
Air Filled	109 lb/in <sup>2</sup> (7,7 kg/cm <sup>2</sup> )
Foam Filled	143 lb/in <sup>2</sup> (10,1 kg/cm <sup>2</sup> )
360/85-28	
Solid	168 lb/in <sup>2</sup> (11,8 kg/cm <sup>2</sup> )
18 x 625, 16 Ply	
Pneumatic	Not Available at Publication
10054	
Outriggers	102 lb/in <sup>2</sup> (7,2 kg/cm <sup>2</sup> )
Tires	
17.50 x 25	
Air Filled	104 lb/in <sup>2</sup> (7,3 kg/cm <sup>2</sup> )
Foam Filled	135 lb/in <sup>2</sup> (9,5 kg/cm <sup>2</sup> )
400/75-28	
Air Filled	110 lb/in <sup>2</sup> (7,7 kg/cm <sup>2</sup> )
Foam Filled	144 lb/in <sup>2</sup> (10,1 kg/cm <sup>2</sup> )
360/85-28	
Solid	172 lb/in <sup>2</sup> (12,1 kg/cm <sup>2</sup> )
18 x 625, 16 Ply	







## Specifications

Pneumatic	Not Available at Publication
12054	
Outriggers	112 lb/in <sup>2</sup> (7,9 kg/cm <sup>2</sup> )
Tires	
17.50 x 25	
Air Filled	123 lb/in <sup>2</sup> (7,9 kg/cm <sup>2</sup> )
Foam Filled	168 lb/in <sup>2</sup> (8,7 kg/cm <sup>2</sup> )
400/75-28, 16 Ply	
Air Filled	112 lb/in <sup>2</sup> (7,9 kg/cm <sup>2</sup> )
Foam Filled	161 lb/in <sup>2</sup> (11,3 kg/cm <sup>2</sup> )
360/85-28	
Solid	183 lb/in <sup>2</sup> (12,9 kg/cm <sup>2</sup> )
18 x 625, 16 Ply	
Pneumatic	Not Available at Publication

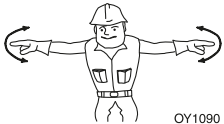
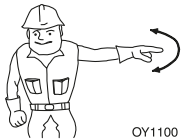

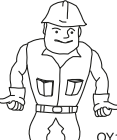
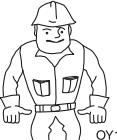

# Hand Signals

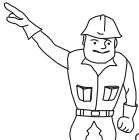
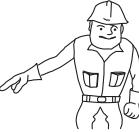
 <p>OY1090</p> <p>EMERGENCY STOP - With both arms extended laterally, hands open downward, move arms back and forth.</p>	 <p>OY1100</p> <p>STOP - With either arm extended laterally, hand open downward, move arm back and forth.</p>	 <p>OY1110</p> <p>STOP ENGINE - Draw thumb or forefinger across throat.</p>
 <p>OY1120</p> <p>RAISE BOOM - With either arm extended horizontally, fingers closed, point thumb upward.</p>	 <p>OY1130</p> <p>LOWER BOOM - With either arm extended horizontally, fingers closed, point thumb downward.</p>	 <p>OY1140</p> <p>MOVE SLOWLY - Place one hand motionless in front of hand giving motion signal. (Raise load slowly shown)</p>
 <p>OY1150</p> <p>EXTEND BOOM - With both hands clenched, point thumbs outward.</p>	 <p>OY1160</p> <p>RETRACT BOOM - With both hands clenched, point thumbs inward.</p>	 <p>OY1170</p> <p>THIS FAR TO GO - With hands raised and open inward, move hands laterally, indicating distance to go.</p>
 <p>OY1180</p> <p>TILT FORKS UP - With one arm held at side, extend other arm upward at about 45 degrees.</p>	 <p>OY1190</p> <p>TILT FORKS DOWN - With one arm held at side, extend other arm downward at about 45 degrees.</p>	

**Special Signals** - When signals for auxiliary equipment functions or conditions not covered are required, they shall be agreed upon in advance by the operator and signalman.



**Corporate Office**  
**JLG Industries, Inc.**  
**1 JLG Drive**  
**McConnellsburg, PA 17233-9533 USA**  
**☎ (717) 485-5161 (Corporate)**  
**☎ (877) 554-5438 (Customer Support)**  
**☎ (717) 485-6417**

**Visit our website for JLG Worldwide Locations.**  
**[www.jlg.com](http://www.jlg.com)**



**OSHKOSH™**