



An Oshkosh Corporation Company

Operation and Safety Manual

Original Instructions - Keep this manual with the machine at all times.

Model
1500AJP
PVC 2001

ANSI **CE**  **AS/NZS** **GB**

31215060
October 1, 2020- Rev B



WARNING

Operating, servicing and maintaining this vehicle or equipment can expose you to chemicals including engine exhaust, carbon monoxide, phthalates, and lead, which are known to the State of California to cause cancer and birth defects or other reproductive harm. To minimize exposure, avoid breathing exhaust, do not idle the engine except as necessary, service your vehicle or equipment in a well-ventilated area and wear gloves or wash your hands frequently when servicing. For more information go to www.P65Warnings.ca.gov.

FOREWORD

The Mobile Elevating Work Platform (MEWP) models covered in this manual are designed and tested to meet or exceed various compliance standards. Please refer to the manufacturer's nameplate affixed to the subject MEWP for specific standard compliance information.

This manual is a very important tool! Keep it with the machine at all times.

The purpose of this manual is to provide owners, users, operators, lessors, and lessees with the precautions and operating procedures essential for the safe and proper machine operation for its intended purpose.

Due to continuous product improvements, JLG Industries, Inc. reserves the right to make specification changes without prior notification. Contact JLG Industries, Inc. for updated information.

Refer to www.JLG.com for Warranty, Product Registration, and other machine-related documentation.

SAFETY ALERT SYMBOLS AND SAFETY SIGNAL WORDS



This is the Safety Alert Symbol. It is used to alert you to the potential personal injury hazards. Obey all safety messages that follow this symbol to avoid possible injury or death

⚠ DANGER

INDICATES AN IMMINENTLY HAZARDOUS SITUATION. IF NOT AVOIDED, WILL RESULT IN SERIOUS INJURY OR DEATH. THIS DECAL WILL HAVE A RED BACKGROUND.

⚠ WARNING

INDICATES A POTENTIALLY HAZARDOUS SITUATION. IF NOT AVOIDED, COULD RESULT IN SERIOUS INJURY OR DEATH. THIS DECAL WILL HAVE AN ORANGE BACKGROUND.

⚠ CAUTION

INDICATES A POTENTIALLY HAZARDOUS SITUATION. IF NOT AVOIDED, MAY RESULT IN MINOR OR MODERATE INJURY. IT MAY ALSO ALERT AGAINST UNSAFE PRACTICES. THIS DECAL WILL HAVE A YELLOW BACKGROUND.

NOTICE

INDICATES INFORMATION OR A COMPANY POLICY THAT RELATES DIRECTLY OR INDIRECTLY TO THE SAFETY OF PERSONNEL OR PROTECTION OF PROPERTY.

⚠ WARNING

THIS PRODUCT MUST COMPLY WITH ALL SAFETY RELATED BULLETINS. CONTACT JLG INDUSTRIES, INC. OR THE LOCAL AUTHORIZED JLG REPRESENTATIVE FOR INFORMATION REGARDING SAFETY-RELATED BULLETINS WHICH MAY HAVE BEEN ISSUED FOR THIS PRODUCT.

NOTICE

JLG INDUSTRIES, INC. SENDS SAFETY RELATED BULLETINS TO THE OWNER OF RECORD OF THIS MACHINE. CONTACT JLG INDUSTRIES, INC. TO ENSURE THAT THE CURRENT OWNER RECORDS ARE UPDATED AND ACCURATE.

NOTICE

JLG INDUSTRIES, INC. MUST BE NOTIFIED IMMEDIATELY IN ALL INSTANCES WHERE JLG PRODUCTS HAVE BEEN INVOLVED IN AN ACCIDENT INVOLVING BODILY INJURY OR DEATH OR WHEN SUBSTANTIAL DAMAGE HAS OCCURRED TO PERSONAL PROPERTY OR THE JLG PRODUCT.

For:

- Accident Reporting
- Product Safety Publications
- Current Owner Updates
- Questions Regarding Product Safety
- Standards and Regulations Compliance Information
- Questions Regarding Special Product Applications
- Questions Regarding Product Modifications

Contact:

Product Safety and Reliability Department
JLG Industries, Inc.
13224 Fountainhead Plaza
Hagerstown, MD 21742
USA

or Your Local JLG Office
(See addresses on inside of manual cover)

In USA:

Toll Free: 877-JLG-SAFE (877-554-7233)

Outside USA:

Phone: 240-420-2661
Fax: 301-745-3713
E-mail: ProductSafety@JLG.com

REVISION LOG

Original Issue A - October 2, 2019
Revision B - October 1, 2020

SECTION - 1 - SAFETY PRECAUTIONS

1.1 GENERAL 1-1

1.2 PRE-OPERATION 1-1

 Operator Training and Knowledge 1-1

 Workplace Inspection 1-2

 Machine Inspection 1-3

1.3 OPERATION 1-3

 General 1-3

 Trip and Fall Hazards 1-4

 Electrocution Hazards 1-5

 Tipping Hazards 1-7

 Crushing and Collision Hazards 1-10

1.4 TOWING, LIFTING, AND HAULING 1-11

1.5 MAINTENANCE 1-11

 Maintenance Hazards 1-11

 Battery Hazards 1-13

SECTION - 2 - USER RESPONSIBILITIES, MACHINE PREPARATION, AND INSPECTION

2.1 PERSONNEL TRAINING 2-1

 Operator Training 2-1

 Training Supervision 2-1

 Operator Responsibility 2-1

2.2 PREPARATION, INSPECTION, AND MAINTENANCE 2-2

 Pre-Start Inspection 2-8

 Daily Walk-Around Inspection 2-9

 Function Check 2-13

 SkyGuard Function Test 2-14

SECTION - 3 - MACHINE CONTROLS AND INDICATORS

3.1 GENERAL 3-1

3.2 CONTROLS AND INDICATORS 3-1

 Ground Control Console 3-2

 Ground Control Indicator Panel 3-8

 Ground Control Console Display Gauge - Machines ...
 using Diesel Exhaust Fluid (DEF) 3-11

 Platform Console 3-14

 Platform Control Indicator Panel 3-22

SECTION - 4 - MACHINE OPERATION

4.1 DESCRIPTION 4-1

4.2 HYDRAULIC SYSTEM WARM UP 4-1

4.3 BOOM OPERATING CHARACTERISTICS AND
LIMITATIONS 4-2

 Capacities 4-2

 Envelope Control System 4-2

 Tower Path Control System 4-3

 Automatic Boom Control System 4-4

 Slow Down System 4-4

 Controlled Boom Angle System 4-5

 Swing Speed Proportioning 4-5

 Stability 4-6

4.4 CAPACITY SELECT 4-6

4.5 ENGINE OPERATION 4-9

 Starting Procedure 4-9

 Shutdown Procedure 4-10

 Air Shutoff Valve (ASOV) (If Equipped) 4-11

TABLE OF CONTENTS

	Fuel Reserve / Shut-Off System.....	4-12
4.6	SELECTIVE CATALYTIC REDUCTION (SCR) - MACHINES ...	
	USING DIESEL EXHAUST FLUID (DEF).....	4-13
	Standstill Cleaning	4-13
	Maintenance Standstill Cleaning Initiation	
	Methods	4-15
	Cancelling Maintenance Standstill	4-15
	Unsuccessful Cleaning Event.....	4-16
4.6	TRAVELING (DRIVING).....	4-19
	Traveling Forward and Reverse	4-22
	Traveling on a Grade	4-23
4.7	STEERING.....	4-23
4.8	EXTENDING THE AXLES	4-23
4.9	PLATFORM	4-24
	Platform Level Adjustment	4-24
	Platform Rotation	4-24
4.10	BOOM.....	4-24
	Swinging the Boom	4-25
	Raising and Lowering the Boom	4-25
	Telescoping the Boom.....	4-26
	Swinging the Jib	4-26
4.11	FUNCTION SPEED CONTROL	4-26
4.12	MACHINE SAFETY SYSTEM OVERRIDE (MSSO)	
	(CE ONLY)	4-26
4.13	SKYGUARD™ OPERATION	4-27
	SkyGuard	4-27
	SkyGuard - SkyLine	4-27
	SkyGuard - SkyEye.....	4-28

	SkyGuard Function Table	4-28
4.14	EMERGENCY TOWING.....	4-29
4.15	SHUT DOWN AND PARK.....	4-30
4.16	LIFTING AND TIE DOWN.....	4-30
	Lifting	4-30
	Tie Down	4-31
4.17	STOWING THE JIB FOR TRANSPORT.....	4-31

SECTION - 5 - LCD DISPLAY PANEL

5.1	DESCRIPTION.....	5-1
5.2	BOOT UP SPLASH SCREEN.....	5-2
5.3	MACHINE OPERATING SCREEN	5-4
	Diagnostic Trouble Code (DTC) Tray	5-5
	Console Tray	5-5
	Icons Tray.....	5-5
	Machine Status Tray	5-5
5.4	KEYSWITCH IN GROUND MODE:.....	5-6
5.5	FUNCTION SPEED.....	5-7
5.6	CAN BUS LOST.....	5-8
5.7	TAKE FOOT OUT	5-9
5.8	PUT FOOT IN	5-10
5.9	BOOM CONTROL SYSTEM (BCS) LAMP ON	5-11
5.10	WIRE ROPE SERVICE.....	5-13
5.11	PLATFORM LEVEL	5-14
5.12	PLATFORM OVERLOAD	5-15
5.13	CAPACITY MODE ERROR	5-16
5.14	CHASSIS STATUS.....	5-17
	Axles Retracted In Transport Position	5-17

TABLE OF CONTENTS

Axles Extended	5-18
Axles Retracted In Out of Transport Position	5-19
Axles In Transient State	5-19
5.15 MACHINE TILTED MODE	5-20
5.16 ENVELOPE STATUS	5-21
5.17 MACHINE MODEL UNKNOWN	5-25
5.18 SELECTIVE CATALYTIC REDUCTION (SCR) CLEANING ..	5-26

SECTION - 6 - EMERGENCY PROCEDURES

6.1 GENERAL	6-1
6.2 INCIDENT NOTIFICATION	6-1
6.3 EMERGENCY OPERATION	6-1
Operator Unable to Control Machine	6-1
Platform or Boom Caught Overhead or Boom	
Movement Prevented by Boom Control System ...	6-2
6.4 EMERGENCY TOWING PROCEDURES	6-2
6.5 MACHINE SAFETY SYSTEM OVERRIDE (MSSO) (CE ONLY)	6-3

SECTION - 7 - ACCESSORIES

7.1 SKYPOWER™	7-3
Generator Output	7-3
Accessory Ratings	7-3
Safety Precautions	7-4
Preparation and Inspection	7-4
Operation	7-4

7.2 SKYWELDER™	7-4
Welding Accessories	7-4
Accessory Ratings	7-7
Safety Precautions	7-7
Preparation and Inspection	7-8
Operation	7-8
7.3 PIPE RACK	7-8
7.4 SOFT TOUCH	7-8
7.5 SKYGLAZIER™	7-10
Safety Precautions	7-10
Specifications	7-11
Preparation and Inspection	7-11
Operation	7-11
7.6 SKYCUTTER	7-12
Accessory Ratings	7-12
Safety Precautions	7-13
Operation	7-13
7.7 FALL ARREST PLATFORM	7-14
7.8 BOLT-ON EXTERNAL FALL ARREST	7-14
Inspection Before Use	7-15

SECTION - 8 - GENERAL SPECIFICATIONS & OPERATOR MAINTENANCE

8.1 INTRODUCTION	8-1
8.2 OPERATING SPECIFICATIONS AND PERFORMANCE DATA	8-1
Operating Specifications	8-1
Dimensional Data	8-2

TABLE OF CONTENTS

	Capacities	8-3
	Tires	8-3
	Engine Data	8-4
	Major Component Weights	8-4
	Hydraulic Oil	8-5
8.3	MAINTENANCE AND LUBRICATION	8-13
8.4	TIRES & WHEELS	8-22
	Tire Damage	8-22
	Tire Replacement	8-22
	Wheel Replacement	8-23
	Wheel Installation	8-23
8.4	SUPPLEMENTAL INFORMATION ONLY AVAILABLE TO CE MACHINES	8-24

SECTION - 9 - INSPECTION AND REPAIR LOG

LIST OF FIGURES

2-1.	Basic Nomenclature - Sheet 1 of 4	2-4	4-14.	Decal Location Sheet 6 of 14	4-38
2-2.	Basic Nomenclature - Sheet 2 of 4	2-5	4-15.	Decal Location Sheet 7 of 14	4-39
2-3.	Basic Nomenclature - Sheet 3 of 4	2-6	4-16.	Decal Location Sheet 8 of 14	4-40
2-4.	Basic Nomenclature - Sheet 4 of 4	2-7	4-17.	Decal Location Sheet 9 of 14	4-41
3-1.	Ground Control Console	3-3	4-18.	Decal Location Sheet 10 of 14	4-42
3-2.	Ground Control Console with Machine Safety System Override (MSSO) (CE Only)	3-4	4-19.	Decal Location Sheet 11 of 14	4-43
3-3.	Ground Control Indicator Panel	3-9	4-20.	Decal Location Sheet 12 of 14	4-44
3-4.	Splash Screen	3-11	4-21.	Decal Location Sheet 13 of 14	4-45
3-5.	Diagnostic Screen	3-12	4-22.	Decal Location Sheet 14 of 14	4-46
3-6.	Engine Diagnostic Screen	3-12	5-1.	LCD Panel	5-1
3-7.	Ground Control Console Display Gauge	3-13	5-2.	Boot Up Splash Screen	5-2
3-8.	Platform Control Console	3-15	5-3.	Manual Screen	5-2
3-9.	Platform Control Indicator Panel	3-23	5-4.	Lanyard Screen	5-3
3-10.	Fuel Level Indicator	3-25	5-5.	Select Capacity Zone Screen	5-3
4-1.	Position of Least Forward Stability	4-7	5-6.	Machine Operating Screen	5-4
4-2.	Position of Least Backward Stability	4-8	5-7.	Keyswitch In Ground Mode Screen	5-6
4-3.	ASOV Reset (Closed to Open Position)	4-11	5-8.	Function Speed Icons	5-7
4-4.	Grade and Side Slopes - Sheet 1 of 2	4-20	5-9.	CAN Bus Lost Screen	5-8
4-5.	Grade and Side Slopes - Sheet 2 of 2	4-21	5-10.	Take Foot Out Screen	5-9
4-6.	Traveling on a Grade	4-23	5-11.	Put Foot In Screen	5-10
4-7.	Drive Disconnect Hub	4-29	5-12.	BCS Lamp Screen	5-12
4-8.	Lifting and Tie Down Chart	4-32	5-13.	Wire Rope Service Screen	5-13
4-9.	Decal Location Sheet 1 of 14	4-33	5-14.	Level System DTC Screen	5-14
4-10.	Decal Location Sheet 2 of 14	4-34	5-15.	Overload DTC Screen	5-15
4-11.	Decal Location Sheet 3 of 14	4-35	5-16.	Capacity Mode Error Screen	5-16
4-12.	Decal Location Sheet 4 of 14	4-36	5-17.	Axles Retracted Screen	5-17
4-13.	Decal Location Sheet 5 of 14	4-37	5-18.	Axles Extended Screen	5-18
			5-19.	Axles In Transient State Screen	5-19

LIST OF FIGURES

5-20.	Machine Tilted Mode Screen	5-20
5-21.	Unrestricted Mode Screen	5-22
5-22.	Restricted Mode Screen	5-23
5-23.	Machine Model Unknown Screen	5-25
5-24.	SCR Cleaning Screen - Sheet 1 of 2	5-27
5-25.	SCR Cleaning Screen - Sheet 2 of 2	5-28
7-1.	SkyWelder™ - Sheet 1 of 2	7-5
7-2.	SkyWelder™ - Sheet 2 of 2	7-6
7-3.	Soft Touch	7-9
7-4.	Bolt-On External Fall Arrest Cable Tension	7-16
7-5.	Bolt-On External Fall Arrest System	7-17
8-1.	Engine Operating Temperature Specifications	8-9
8-2.	Hydraulic Oil Operation Chart - Sheet 1 of 2	8-10
8-3.	Hydraulic Oil Operation Chart - Sheet 2 of 2	8-11
8-4.	Maintenance and Lubrication Diagram	8-12

1-1	Minimum Approach Distances (M.A.D.)	1-6	9-1	Inspection and Repair Log.....	9-1
1-2	Beaufort Scale (For Reference Only).....	1-9			
2-1	Inspection and Maintenance Table	2-3			
4-1	Maintenance Standstill Cleaning.....	4-17			
4-2	Cleaning When Crystallization is Detected During SCR.....	4-18			
4-3	Decal Legend	4-47			
7-1	Available Accessories	7-1			
7-2	Options/Accessories Relationship Table.....	7-2			
7-3	Welding Characteristics	7-7			
7-4	Specifications for SkyGlazier™	7-11			
7-5	Plasma Cutter Characteristics.....	7-12			
8-1	Operating Specifications	8-1			
8-2	Dimensional Data	8-2			
8-3	Capacities	8-3			
8-4	Tire Specifications.....	8-3			
8-5	Engine Data - Deutz TD 3.6L.....	8-4			
8-6	Critical Stability Weights.....	8-4			
8-7	Hydraulic Oil	8-5			
8-8	Mobilfluid 424 Specs	8-5			
8-9	Mobil DTE 10 Excel 32 Specs.....	8-6			
8-10	UCon Hydrolube HP-5046.....	8-6			
8-11	Mobil EAL H 46 Specs	8-7			
8-12	Mobil EAL 46 Specs	8-7			
8-13	Exxon Univil HVI 26 Specs.....	8-8			
8-14	Quintolubric 888-46.....	8-8			
8-15	Lubrication Specifications	8-13			
8-16	Wheel Torque Chart.....	8-24			

LIST OF TABLES

SECTION 1. SAFETY PRECAUTIONS

1.1 GENERAL

This section outlines the necessary precautions for proper and safe machine usage and maintenance. It is mandatory that a daily routine is established based on the content of this manual to promote proper machine usage. A maintenance program, using the information provided in this manual and the Service and Maintenance Manual, must also be established by a qualified person and must be followed to ensure that the machine is safe to operate.

The owner/user/operator/lessor/lessee of the machine must not accept operating responsibility until this manual has been read, training is accomplished, and operation of the machine has been completed under the supervision of an experienced and qualified operator.

This section contains the responsibilities of the owner, user, operator, lessor, and lessee concerning safety, training, inspection, maintenance, application, and operation. If there are any questions with regard to safety, training, inspection, maintenance, application, and operation, please contact JLG Industries, Inc. ("JLG").

⚠ WARNING

FAILURE TO COMPLY WITH THE SAFETY PRECAUTIONS LISTED IN THIS MANUAL COULD RESULT IN MACHINE DAMAGE, PROPERTY DAMAGE, PERSONAL INJURY OR DEATH.

1.2 PRE-OPERATION

Operator Training and Knowledge

- Read, understand, and study the Operation and Safety Manual in its entirety before operating the machine. For clarification, questions, or additional information regarding any portions of this manual, contact JLG Industries, Inc.

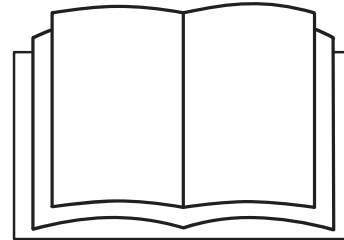

SECTION 1 - SAFETY PRECAUTIONS

- Only personnel who have received proper training regarding the inspection, application and operation of MEWPs (including recognition and avoiding hazards associated with their operation) shall be authorized to operate a MEWP.
- Only properly trained personnel who have received unit-specific familiarization shall operate a MEWP. The user shall determine if personnel are qualified to operate the MEWP prior to operation.
- Read, understand, and obey all DANGERS, WARNINGS, CAUTIONS, and operating instructions on the machine and in this manual.
- Ensure that the machine is to be used in a manner which is within the scope of its intended application as determined by JLG.
- All operating personnel must have a thorough understanding of the intended purpose and function of the MEWP controls, including platform, ground, and emergency descent controls.
- Read, understand, and obey all applicable employer, local, and governmental regulations as they pertain to your utilization and application of the machine.

Workplace Inspection

- Precautions to avoid all hazards in the work area must be taken by the user before and during operation of the machine.
- Do not operate or raise the platform from a position on trucks, trailers, railway cars, floating vessels, scaffolds or other equipment unless the application is approved in writing by JLG.
- Before operation, check work area for overhead hazards such as electric lines, bridge cranes, and other potential overhead obstructions.
- Check operating surfaces for holes, bumps, drop-offs, obstructions, debris, concealed holes, and other potential hazards.
- Check the work area for hazardous locations. Do not operate the machine in hazardous environments unless approved for that purpose by JLG.
- Ensure that the ground conditions are adequate to support the maximum tire load indicated on the tire load decals located on the chassis adjacent to each wheel. Do not travel on unsupported surfaces.

Machine Inspection

- Do not operate this machine until the inspections and functional checks as specified in Section 2 of this manual have been performed.
- Do not operate this machine until it has been serviced and maintained according to the maintenance and inspection requirements as specified in the machine's Service and Maintenance Manual.
- Ensure all safety devices are operating properly. Modification of these devices is a safety violation.

WARNING

MODIFICATION OR ALTERATION OF A MEWP SHALL BE MADE ONLY WITH PRIOR WRITTEN PERMISSION FROM THE MANUFACTURER.

- Do not operate any machine on which the safety or instruction placards or decals are missing or illegible.
- Check the machine for modifications to original components. Ensure that any modifications have been approved by JLG.
- Avoid accumulation of debris on platform floor. Keep mud, oil, grease, and other slippery substances from footwear and platform floor.

1.3 OPERATION

General

- Machine operation requires your full attention. Bring the machine to a full stop before using any device, i.e. cell phones, two-way radios, etc. that will distract your attention from safely operating the machine.
- Do not use the machine for any purpose other than positioning personnel, their tools, and equipment.
- Before operation, the user must be familiar with the machine capabilities and operating characteristics of all functions.
- Never operate a malfunctioning machine. If a malfunction occurs, shut down the machine. Remove the unit from service and notify the proper authorities.
- Do not remove, modify, or disable any safety devices.
- Never slam a control switch or lever through neutral to an opposite direction. Always return switch to neutral and stop before moving the switch to the next function. Operate controls with slow and even pressure.
- Do not allow personnel to tamper with or operate the machine from the ground with personnel in the platform, except in an emergency.

SECTION 1 - SAFETY PRECAUTIONS

- Do not carry materials directly on platform railing unless approved by JLG.
- When two or more persons are in the platform, the operator shall be responsible for all machine operations.
- Always ensure that power tools are properly stowed and never left hanging by their cord from the platform work area.
- When driving, always position boom over rear axle in line with the direction of travel. Remember, if boom is over the front axle, steer and drive functions will be reversed.
- Do not assist a stuck or disabled machine by pushing or pulling except by pulling at the chassis tie-down lugs.
- Fully lower platform and shut off all power before leaving machine.
- Remove all rings, watches, and jewelry when operating machine. Do not wear loose fitting clothing or long hair unrestrained which may become caught or entangled in equipment.
- Persons under the influence of drugs or alcohol or who are subject to seizures, dizziness or loss of physical control must not operate this machine.

- Hydraulic cylinders are subject to thermal expansion and contraction. This may result in changes to the platform position while the machine is stationary. Factors affecting thermal movement can include the length of time the machine will remain stationary, hydraulic oil temperature, ambient air temperature, and boom and platform position.

Trip and Fall Hazards

- Prior to operation, ensure all gates are closed and fastened in their proper position.
- During operation, occupants in the platform must wear a full body harness with a lanyard attached to an authorized lanyard anchorage point. Attach only one (1) lanyard per lanyard anchorage point.

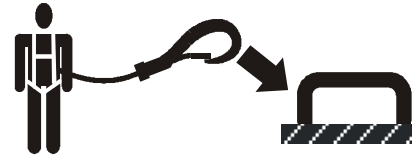

- Enter and exit only through gate area. Use extreme caution when entering or leaving platform. Ensure that the platform assembly is fully lowered. Face the platform when entering or leaving the platform. Always maintain “three point contact” with the machine, using two hands and one foot or two feet and one hand at all times during entry and exit.

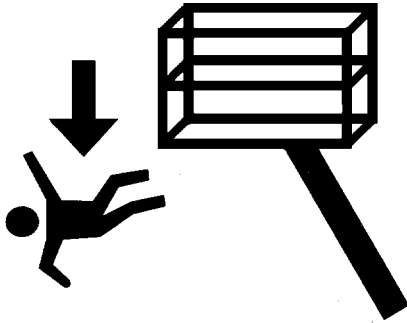

- Keep both feet firmly positioned on the platform floor at all times. Never position ladders, boxes, steps, planks, or similar items on unit to provide additional reach for any purpose.
- Keep oil, mud, and slippery substances cleaned from footwear and the platform floor.

Electrocution Hazards

- This machine is not insulated and does not provide protection from contact or proximity to electrical current.

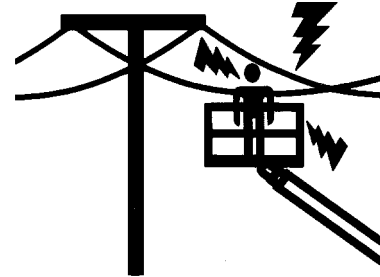

- It is not recommended to use the machine during lightning. To prevent injury or machine damage if lightning occurs during operation, lower the boom and shut down the machine in a safe and secure location.

SECTION 1 - SAFETY PRECAUTIONS

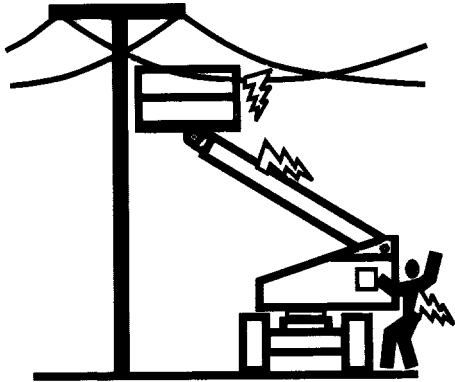

- Maintain distance from electrical lines, apparatus, or any energized (exposed or insulated) parts according to the Minimum Approach Distance (MAD) as shown in Table 1-1.
- Allow for machine movement and electrical line swaying.

Table 1-1. Minimum Approach Distances (M.A.D.)

Voltage Range (Phase to Phase)	MINIMUM APPROACH DISTANCE in Feet (Meters)
0 to 50 KV	10 (3)
Over 50KV to 200 KV	15 (5)
Over 200 KV to 350 KV	20 (6)
Over 350 KV to 500 KV	25 (8)
Over 500 KV to 750 KV	35 (11)
Over 750 KV to 1000 KV	45 (14)

NOTE: *This requirement shall apply except where employer, local or governmental regulations are more stringent.*

- Maintain a clearance of at least 10 ft. (3m) between any part of the machine and its occupants, their tools, and their equipment from any electrical line or apparatus carrying up to 50,000 volts. One foot additional clearance is required for every additional 30,000 volts or less.

- The minimum approach distance may be reduced if insulating barriers are installed to prevent contact, and the barriers are rated for the voltage of the line being guarded. These barriers shall not be part of (or attached to) the machine. The minimum approach distance shall be reduced to a distance within the designed working dimensions of the insulating barrier. This determination shall be made by a qualified person with respect to electrical transmission and distribution in accordance with the employer, local, or governmental requirements for work practices near energized equipment.

⚠ DANGER

DO NOT MANEUVER MACHINE OR PERSONNEL INSIDE PROHIBITED ZONE (MAD). ASSUME ALL ELECTRICAL PARTS AND WIRING ARE ENERGIZED UNLESS KNOWN OTHERWISE.

Tipping Hazards

- Ensure that the ground conditions are adequate to support the maximum tire load indicated on the tire load decals located on the chassis adjacent to each wheel. Do not travel on unsupported surfaces.
- The user must be familiar with the operating surface before driving. Do not exceed the allowable sideslope and grade while driving.

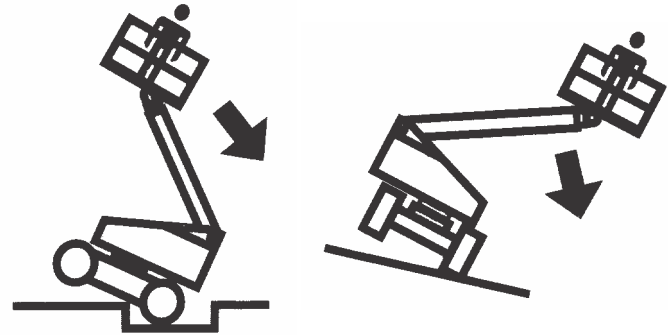

- Do not elevate platform or drive with platform elevated while on or near a sloping, uneven, or soft surface. Ensure machine is positioned on a smooth, firm surface within the limits of the maximum operating slope before elevating platform or driving with the platform in the elevated position.

SECTION 1 - SAFETY PRECAUTIONS

- Before driving on floors, bridges, trucks, and other surfaces, check allowable capacity of the surfaces.
- Never exceed the maximum work load as specified on the platform. Keep all loads within the confines of the platform, unless authorized by JLG.
- Keep the chassis of the machine a minimum of 2 ft. (0.6m) from holes, bumps, drop-offs, obstructions, debris, concealed holes, and other potential hazards at the ground level.
- Do not push or pull any object with the boom.
- Never attempt to use the machine as a crane. Do not tie-off machine to any adjacent structure. Never attach wire, cable, or any similar items to platform.
- If boom assembly or platform is in a position that one or more wheels are off the ground, all persons must be removed before attempting to stabilize the machine. Use cranes, forklift trucks, or other appropriate equipment to stabilize machine.
- Do not operate the machine when wind conditions, including gusts, exceed specifications shown in section 8-2 of this manual or as shown on the capacity placard of the platform billboard. Factors affecting wind speed are; platform elevation, surrounding structures, local weather events, and approaching storms.
- Wind speed can be significantly greater at height than at ground level.
- Wind speed can change rapidly. Always consider approaching weather events, the time required to lower the platform, and methods to monitor current and potential wind conditions.
- Do not cover or increase surface area of the platform or the load. Do not carry large surface area items in the platform when operating outdoors. The addition of such items increases the exposed wind area of the machine. Increased areas exposed to wind will decrease stability.
- Do not increase the platform size with unauthorized modifications or attachments.

NOTICE

DO NOT OPERATE THE MACHINE WHEN WIND CONDITIONS EXCEED SPECIFICATIONS SHOWN IN SECTION 7.2 OR AS SHOWN ON THE CAPACITY PLACARD ON THE PLATFORM BILLBOARD.

Table 1-2. Beaufort Scale (For Reference Only)

Beaufort Number	Wind Speed		Description	Land Conditions
	mph	m/s		
0	0	0-0.2	Calm	Calm. Smoke rises vertically
1	1-3	0.3-1.5	Light air	Wind motion visible in smoke
2	4-7	1.6-3.3	Light breeze	Wind felt on exposed skin. Leaves rustle
3	8-12	3.4-5.4	Gentle breeze	Leaves and smaller twigs in constant motion
4	13-18	5.5-7.9	Moderate breeze	Dust and loose paper raised. Small branches begin to move.
5	19-24	8.0-10.7	Fresh breeze	Smaller trees sway.
6	25-31	10.8-13.8	Strong breeze	Large branches in motion. Flags waving near horizontal. Umbrella use becomes difficult.
7	32-38	13.9-17.1	Near Gale/Moderate Gale	Whole trees in motion. Effort needed to walk against the wind.
8	39-46	17.2-20.7	Fresh Gale	Twigs broken from trees. Cars veer on road.
9	47-54	20.8-24.4	Strong Gale	Light structure damage.

SECTION 1 - SAFETY PRECAUTIONS

Crushing and Collision Hazards

- Approved head gear must be worn by all operating and ground personnel.
- Watch for obstructions around machine and overhead when driving. Check clearances above, on sides, and bottom of platform during all operations.

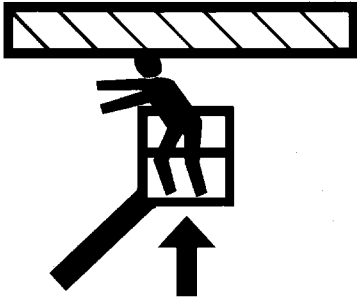

- During operation, keep all body parts inside platform railing.
- Use the boom functions, not the drive function, to position the platform close to obstacles.
- Always post a lookout when driving in areas where vision is obstructed.

- Keep non-operating personnel at least 6 ft. (1.8m) away from machine during all operations.
- Under all travel conditions, the operator must limit travel speed according to conditions of ground surface, congestion, visibility, slope, location of personnel, and other factors.
- Be aware of stopping distances in all drive speeds. When driving in high speed, reduce drive speed before stopping. Travel grades in low speed only.
- Do not use high speed drive in restricted or close quarters or when driving in reverse.
- Exercise extreme caution at all times to prevent obstacles from striking or interfering with operating controls and persons in the platform.
- Ensure that operators of other overhead and floor level machines are aware of the MEWP's presence. Disconnect power to overhead cranes.
- Do not operate over ground personnel. Warn personnel not to work, stand, or walk under a raised boom or platform. Position barricades on floor if necessary.

1.4 TOWING, LIFTING, AND HAULING

- Never allow personnel in platform while towing, lifting, or hauling.
- This machine should not be towed, except in the event of emergency, malfunction, power failure, or loading/unloading. Refer to the Emergency Procedures section of this manual for emergency towing procedures.
- Ensure boom is in the stowed position and, if equipped, the turntable locked prior to towing, lifting or hauling. The platform must be completely empty of tools.
- When lifting machine, lift only at designated areas of the machine. Lift the unit with equipment of adequate capacity.
- Refer to the Machine Operation section of this manual for lifting information.

1.5 MAINTENANCE

This sub-section contains general safety precautions which must be observed during maintenance of this machine. Additional precautions to be observed during machine maintenance are inserted at the appropriate points in this manual and in the Service and Maintenance Manual. It is of utmost importance that maintenance personnel pay strict attention to these precautions to avoid possible injury to personnel or damage to the machine or property. A maintenance program must be established by a qualified person and must be followed to ensure that the machine is safe.

Maintenance Hazards

- Shut off power to all controls and ensure that all moving parts are secured from inadvertent motion prior to performing any adjustments or repairs.
- Never work under an elevated platform until it has been fully lowered to the full down position, if possible, or otherwise supported and restrained from movement with appropriate safety props, blocking, or overhead supports.
- DO NOT attempt to repair or tighten any hydraulic hoses or fittings while the machine is powered on or when the hydraulic system is under pressure.
- Always relieve hydraulic pressure from all hydraulic circuits before loosening or removing hydraulic components.

SECTION 1 - SAFETY PRECAUTIONS

- DO NOT use your hand to check for leaks. Use a piece of cardboard or paper to search for leaks. Wear gloves to help protect hands from spraying fluid.



- Use only replacement parts or components that are approved by JLG. To be considered approved, replacement parts or components must be identical or equivalent to original parts or components.
- Never attempt to move heavy parts without the aid of a mechanical device. Do not allow heavy objects to rest in an unstable position. Ensure adequate support is provided when raising components of the machine.
- Do not use machine as a ground for welding.
- When performing welding or metal cutting operations, precautions must be taken to protect the chassis from direct exposure to weld and metal cutting spatter.
- Do not refuel the machine with the engine running.
- Use only approved non-flammable cleaning solvents.
- Do not replace items critical to stability, such as batteries or solid tires, with items of different weight or specification. Do not modify unit in any way to affect stability.
- Refer to the Service and Maintenance Manual for the weights of critical stability items.

WARNING

MODIFICATION OR ALTERATION OF A MEWP SHALL BE MADE ONLY WITH PRIOR WRITTEN PERMISSION FROM THE MANUFACTURER.

Battery Hazards

- Always disconnect batteries when servicing electrical components or when performing welding on the machine.
- Do not allow smoking, open flame, or sparks near battery during charging or servicing.
- Do not contact tools or other metal objects across the battery terminals.
- Always wear hand, eye, and face protection when servicing batteries. Ensure that battery acid does not come in contact with skin or clothing.

CAUTION

BATTERY FLUID IS HIGHLY CORROSIVE. AVOID CONTACT WITH SKIN AND CLOTHING AT ALL TIMES. IMMEDIATELY RINSE ANY CONTACTED AREA WITH CLEAN WATER AND SEEK MEDICAL ATTENTION.

- Charge batteries only in a well ventilated area.
- Avoid overfilling the battery fluid level. Add distilled water to batteries only after the batteries are fully charged.

SECTION 2. USER RESPONSIBILITIES, MACHINE PREPARATION, AND INSPECTION

2.1 PERSONNEL TRAINING

The Mobile Elevating Work Platform (MEWP) is a personnel handling device; so it is necessary that it be operated and maintained only by trained personnel.

Operator Training

Operator training must cover:

1. Reading and understanding the Operation and Safety Manual.
2. Thorough understanding of the intended purpose and function of the MEWP controls, including platform, ground, and emergency descent controls.
3. Control labels, instructions, and warnings on the machine.
4. Applicable regulations, standards, and safety rules.
5. Use of approved fall protection equipment.
6. Enough knowledge of the mechanical operation of the machine to recognize a malfunction or potential malfunction.

7. The safest means to operate the machine where overhead obstructions, other moving equipment, and obstacles, depressions, holes, and drop-offs exist.
8. Means to avoid the hazards of unprotected electrical conductors.
9. Selection of the appropriate MEWP and available options for the work to be performed considering specific job requirements, with involvement from the MEWP owner, user, and/or supervisor.
10. The responsibility of the operator to ensure all platform occupants have a basic level of knowledge to work safely on the MEWP, and to inform them of applicable regulations, standards, and safety rules.
11. The requirement for familiarization in addition to training.

Training Supervision

Training must be delivered by a qualified person in an open area, free of hazards until the trainee has demonstrated the ability to safely control and operate the machine.

SECTION 2 - USER RESPONSIBILITIES, MACHINE PREPARATION, AND INSPECTION

Operator Responsibility

The operator must be instructed they have the responsibility and authority to shut down the machine in case of a malfunction or other unsafe condition of either the machine or the job site.

Machine Familiarization

NOTE: *Responsibilities for familiarization may vary by region.*

Only properly trained personnel who have received unit-specific familiarization shall operate a MEWP. The user shall determine if personnel are qualified to operate the MEWP prior to operation. The user shall ensure that after familiarization, the operator operates the MEWP for a sufficient period of time to achieve proficiency. When authorized by the user, self-familiarization can be achieved, if authorized, by a properly trained operator reading, understanding and following the manufacturer's operator's manual.

Prior to users authorization of an operator to use a specific model of MEWP, the user shall ensure the operator is familiarized on the following:

1. Location of the manual storage compartment and the requirement to ensure the required manual(s) are present on the MEWP;
2. Purpose and function of the machine controls and indicators at the platform and ground control stations;

3. Purpose, location, and function of the emergency controls;
4. Operating characteristics and limitations;
5. Features and devices;
6. Accessories and optional equipment.

2.2 PREPARATION, INSPECTION, AND MAINTENANCE

The following table covers machine inspections and maintenance required by JLG Industries, Inc. Consult local regulations for further requirements for MEWPs. The frequency of inspections and maintenance must be increased as necessary when the machine is used in a harsh or hostile environment, if the machine is used with increased frequency, or if the machine is used in a severe manner.

SECTION 2 - USER RESPONSIBILITIES, MACHINE PREPARATION, AND INSPECTION

Table 2-1. Inspection and Maintenance Table

Type	Frequency	Primary Responsibility	Service Qualification	Reference
Pre-Start Inspection	Before using each day; or whenever there's an Operator change.	User or Operator	User or Operator	Operation and Safety Manual
Pre-Delivery Inspection (See Note)	Before each sale, lease, or rental delivery.	Owner, Dealer, or User	Qualified JLG Mechanic	Service and Maintenance Manual and applicable JLG inspection form
Frequent Inspection (See Note)	In service for 3 months or 150 hours, whichever comes first; or Out of service for a period of more than 3 months; or Purchased used.	Owner, Dealer, or User	Qualified JLG Mechanic	Service and Maintenance Manual and applicable JLG inspection form
Annual Machine Inspection (See Note)	Annually, no later than 13 months from the date of prior inspection.	Owner, Dealer, or User	Factory Trained Service Technician (Recommended)	Service and Maintenance Manual and applicable JLG inspection form
Preventative Maintenance	At intervals as specified in the Service and Maintenance Manual.	Owner, Dealer, or User	Qualified JLG Mechanic	Service and Maintenance Manual

NOTE: Inspection forms are available from JLG. Use the Service and Maintenance Manual to perform inspections.

NOTICE

JLG INDUSTRIES, INC. RECOGNIZES A FACTORY TRAINED SERVICE TECHNICIAN AS A PERSON WHO HAS SUCCESSFULLY COMPLETED THE JLG SERVICE TRAINING SCHOOL FOR THE SPECIFIC JLG PRODUCT MODEL.

SECTION 2 - USER RESPONSIBILITIES, MACHINE PREPARATION, AND INSPECTION

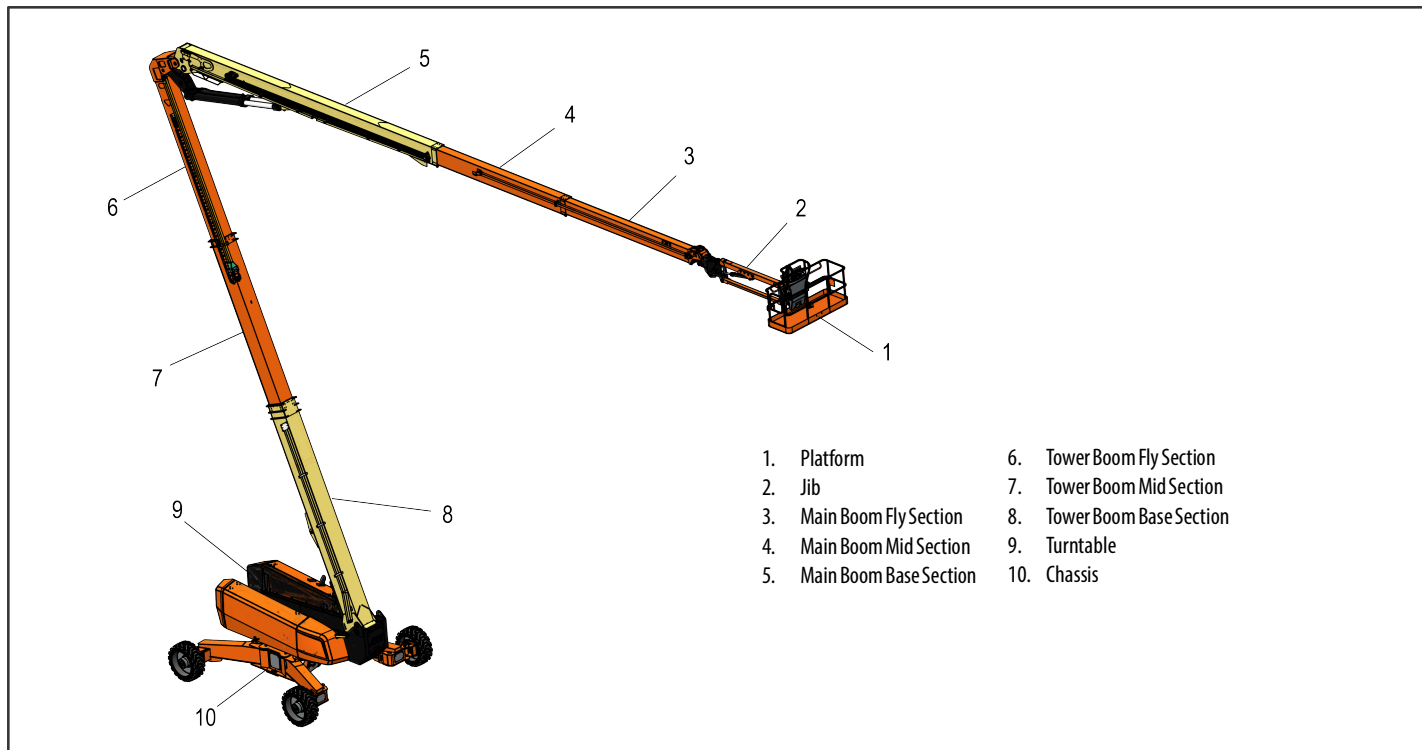

Figure 2-1. Basic Nomenclature - Sheet 1 of 4

SECTION 2 - USER RESPONSIBILITIES, MACHINE PREPARATION, AND INSPECTION

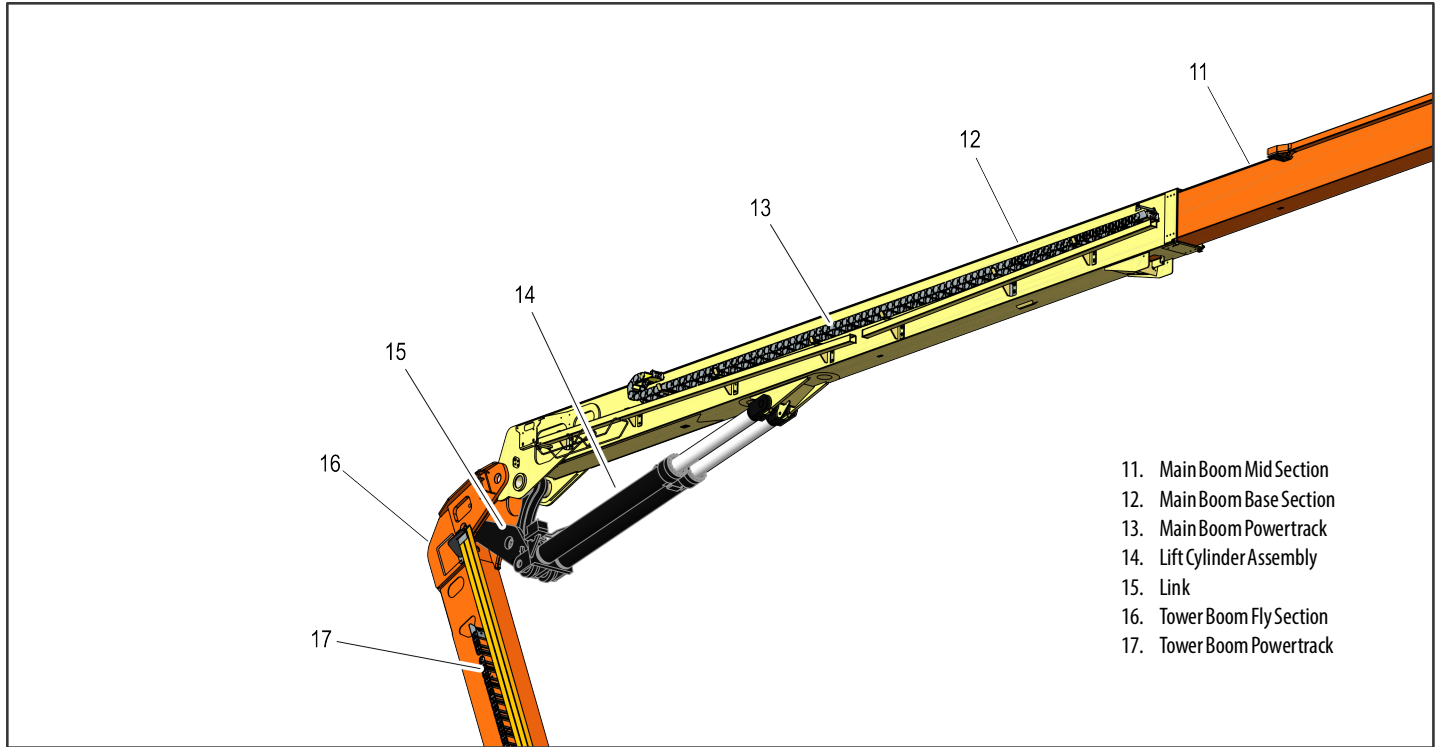

Figure 2-2. Basic Nomenclature - Sheet 2 of 4

SECTION 2 - USER RESPONSIBILITIES, MACHINE PREPARATION, AND INSPECTION

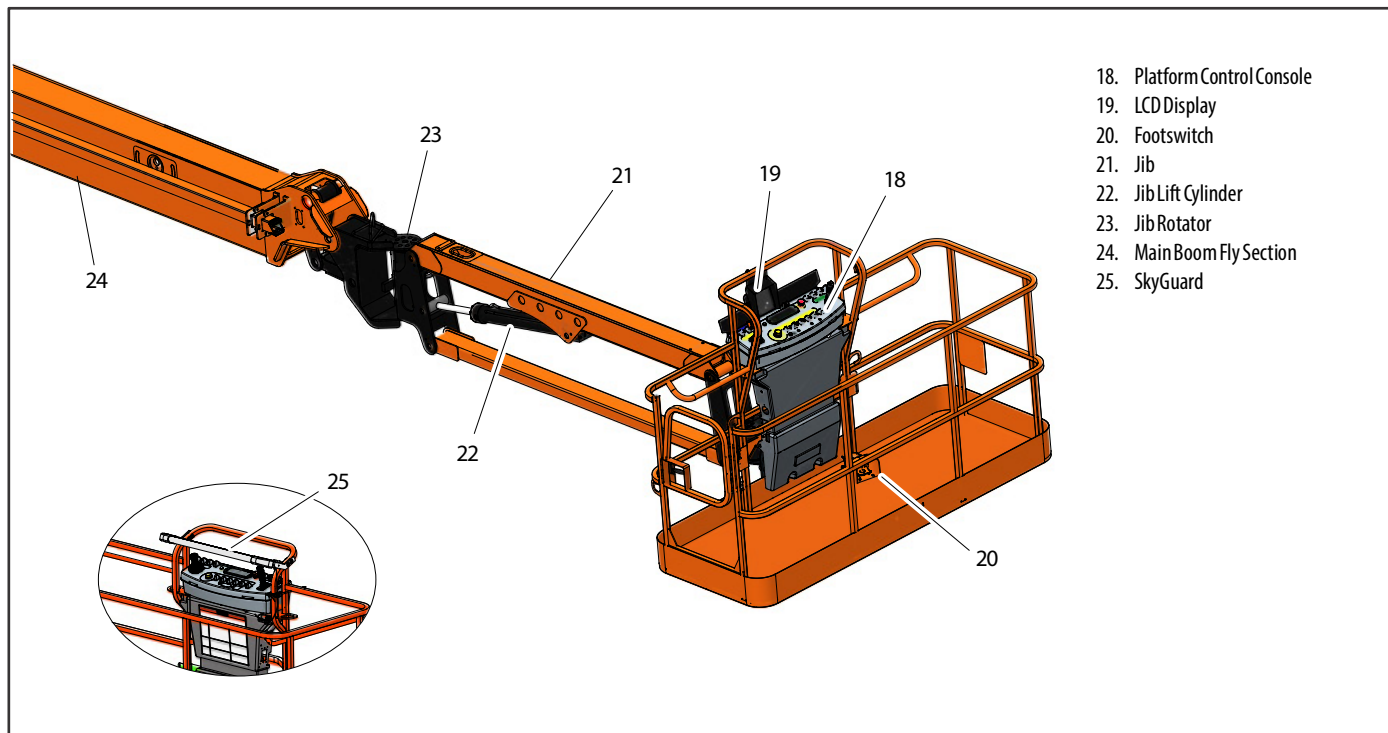

Figure 2-3. Basic Nomenclature - Sheet 3 of 4

SECTION 2 - USER RESPONSIBILITIES, MACHINE PREPARATION, AND INSPECTION

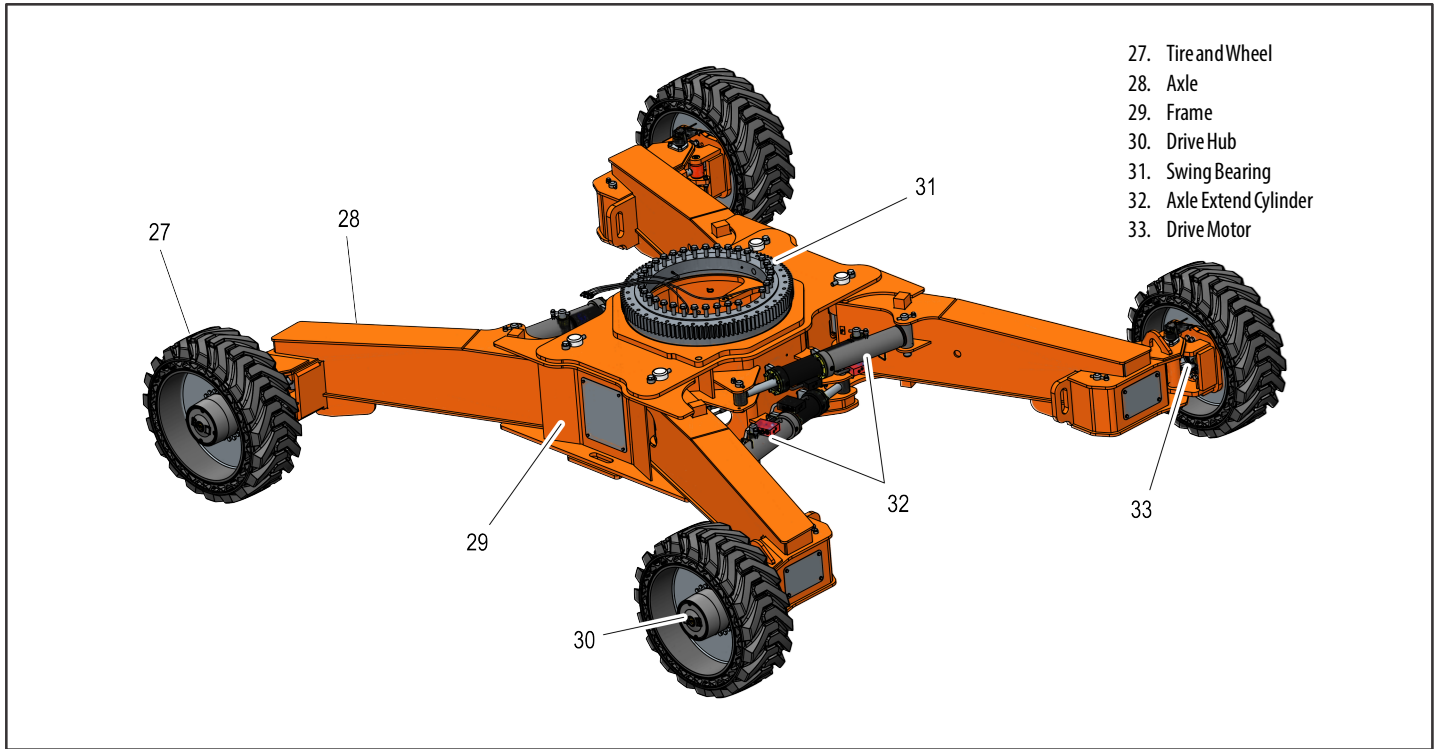

Figure 2-4. Basic Nomenclature - Sheet 4 of 4

SECTION 2 - USER RESPONSIBILITIES, MACHINE PREPARATION, AND INSPECTION

Pre-Start Inspection

The Pre-Start Inspection should include each of the following:

1. **Cleanliness** – Check all surfaces for leakage (oil, fuel, or battery fluid) or foreign objects. Report any leakage to the proper maintenance personnel.
2. **Structure** - Inspect the machine structure for dents, damage, weld or parent metal cracks or other discrepancies.

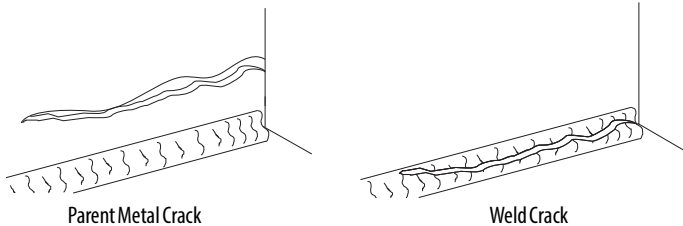

3. **Decals and Placards** – Check all for cleanliness and legibility. Make sure none of the decals and placards are missing. Make sure all illegible decals and placards are cleaned or replaced.
4. **Operation and Safety Manuals** – Make sure a copy of the Operation and Safety Manual, AEM Safety Manual (ANSI markets only), and ANSI Manual of Responsibilities (ANSI markets only) is enclosed in the weather resistant storage container.

5. **Walk-Around Inspection** – Perform as instructed.
6. **Battery** – Charge as required.
7. **Fuel** (Combustion Engine Powered Machines) – Add the proper fuel as necessary.
8. **Engine Oil Supply** - Ensure the engine oil level is at the Full mark on the dipstick and the filler cap is secure.
9. **Hydraulic Oil** – Check the hydraulic oil level. Ensure hydraulic oil is added as required.
10. **Accessories/Attachments** - Refer to the Accessories section in this manual or accessory installed upon the machine for specific inspection, operation, and maintenance instructions.
11. **Function Check** – Once the Walk-Around Inspection is complete, perform a functional check of all systems in an area free of overhead and ground level obstructions. Refer to Section 4 for more specific operating instructions.
12. **Boom Control System Check** - Perform a check of the boom control system as specified in this section.

SECTION 2 - USER RESPONSIBILITIES, MACHINE PREPARATION, AND INSPECTION

- 13. Platform Gate** - Keep gate and surrounding area clean and unobstructed. Verify the gate closes properly and is not bent or damaged. Keep gate closed at all times except when entering/exiting the platform and loading/unloading materials.
- 14. Lanyard Attach Points** - During operation, occupants in the platform must wear a full body harness with a lanyard attached to an authorized lanyard anchorage point. Attach only one (1) lanyard per lanyard anchorage point.

WARNING

IF THE MACHINE DOES NOT OPERATE PROPERLY, TURN OFF THE MACHINE IMMEDIATELY! REPORT THE PROBLEM TO THE PROPER MAINTENANCE PERSONNEL. DO NOT OPERATE THE MACHINE UNTIL IT IS DECLARED SAFE FOR OPERATION.

Walk-Around Inspection

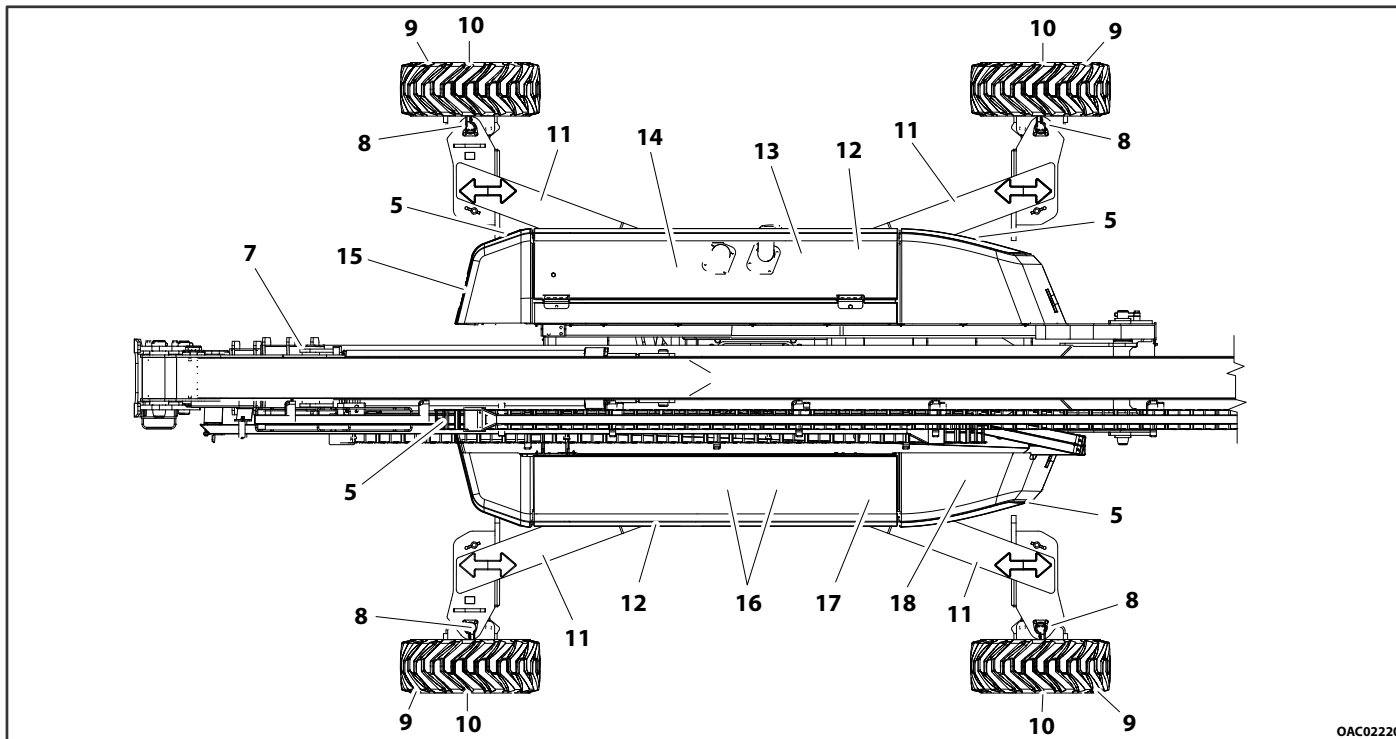

OAC02220

SECTION 2 - USER RESPONSIBILITIES, MACHINE PREPARATION, AND INSPECTION

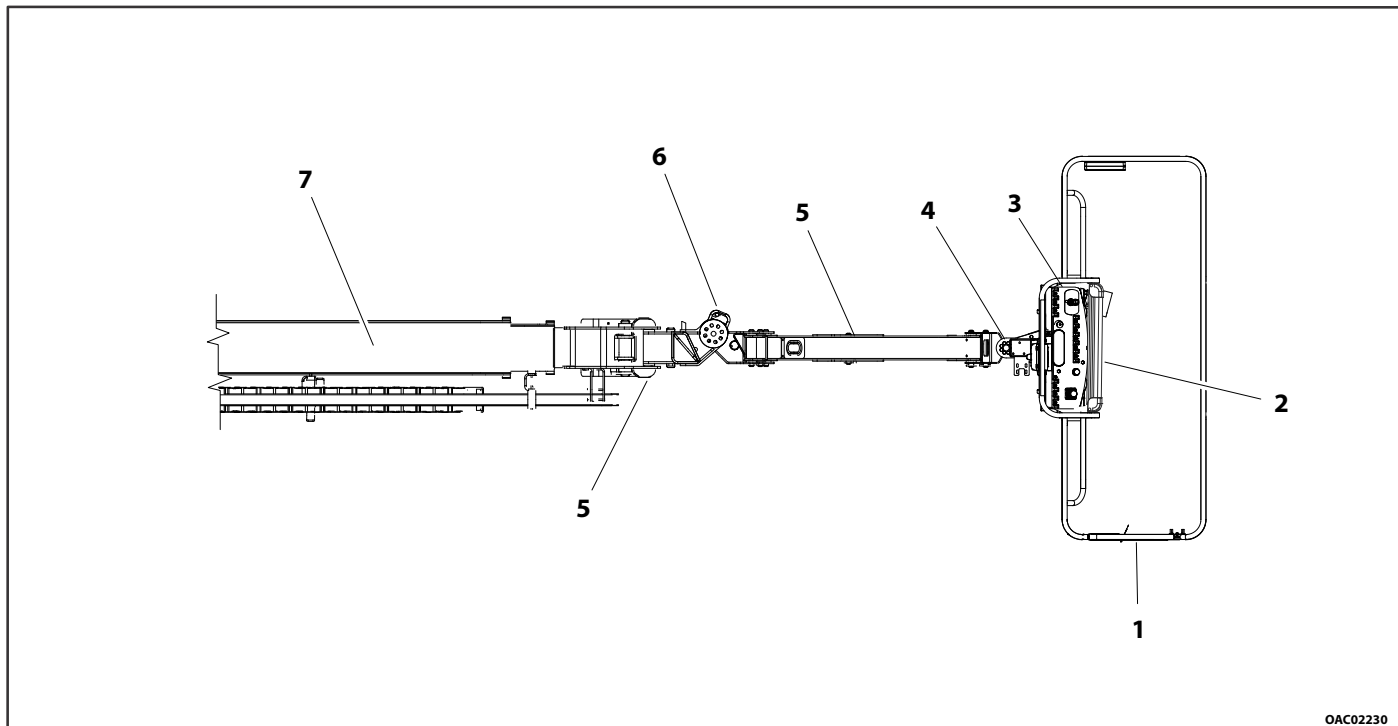

SECTION 2 - USER RESPONSIBILITIES, MACHINE PREPARATION, AND INSPECTION

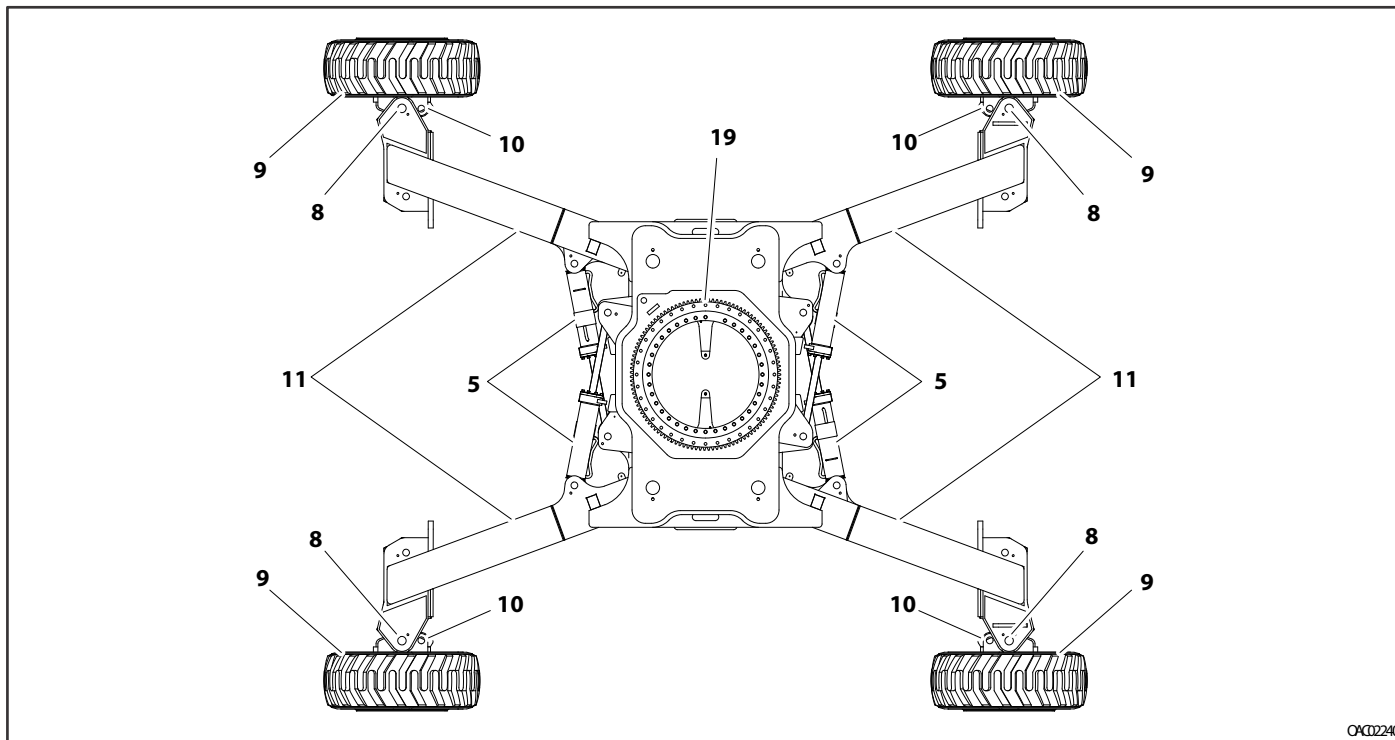

SECTION 2 - USER RESPONSIBILITIES, MACHINE PREPARATION, AND INSPECTION

Begin the Walk-Around Inspection at Item 1, as noted on the diagram. Continue checking each item in sequence for the conditions listed in the following checklist.

WARNING

TO AVOID POSSIBLE INJURY, BE SURE MACHINE POWER IS OFF. DO NOT OPERATE MACHINE UNTIL ALL MALFUNCTIONS HAVE BEEN CORRECTED.

NOTICE

DO NOT OVERLOOK VISUAL INSPECTION OF CHASSIS UNDERSIDE. CHECKING THIS AREA MAY RESULT IN DISCOVERY OF CONDITIONS WHICH COULD CAUSE EXTENSIVE MACHINE DAMAGE.

***INSPECTION NOTE:** On all components, make sure there are no loose or missing parts, that they are securely fastened, and no visible damage, leaks or excessive wear exists in addition to any other criteria mentioned.*

- 1. Platform Assembly and Gate** - Footswitch works properly, not modified, disabled or blocked. Gate latch and hinges in working condition.
- 2. SkyGuard** - See Inspection Note.
- 3. Platform Control Console** - Switches and levers return to neutral when activated and released, decals/placards secure and legible, control markings legible.
- 4. Platform Rotator** - See Inspection Note.
- 5. All Hydraulic Cylinders** - No visible damage; pivot pins and hydraulic hoses undamaged, not leaking.
- 6. Jib Rotator** - See Inspection Note.
- 7. Boom Sections/Turntable** - See Inspection Note.
- 8. Steering Spindles and Sensors** - See Inspection Note.
- 9. Wheel/Tire Assemblies** - Properly secured, no missing lug bolts. Inspect for worn tread, cuts, tears or other discrepancies. Inspect wheels for damage and corrosion.
- 10. Drive Motor, Brake, and Hub** - No evidence of leakage.
- 11. Axles** - See Inspection Note.
- 12. Hood Assemblies** - See Inspection Note.
- 13. Hydraulic Pump** - See Inspection Note.
- 14. Air Shutoff Valve (ASOV) (If Equipped)** - See Inspection Note.

SECTION 2 - USER RESPONSIBILITIES, MACHINE PREPARATION, AND INSPECTION

15. **Ground Control Console** - Switches and levers return to neutral when activated and released, decals/placards secure and legible, control markings legible.
16. **Swing Drive** - No evidence of damage.
17. **Diesel Exhaust Fluid (DEF) Tank (If Equipped)** - Proper Fluid Level. See Inspection Note.
18. **Auxiliary Hydraulic Pump** - See Inspection Note.
19. **Turntable Bearing** - Evidence of proper lubrication. No evidence of loose bolts or looseness between bearing and machine.

Function Check

Perform the Function Check as follows:

1. From the ground control console with no load in the platform:
 - a. Ensure that all machine functions are disabled when the Emergency Stop Button is pushed in.
 - b. Ensure all functions stop when the function switch is released.
2. From the platform control console:
 - a. Ensure the control console is firmly secured in the proper location.
 - b. Check all guards protecting the switches or locks are in place.
 - c. Ensure all machine functions are disabled when the Emergency Stop Button is pushed in.
 - d. Ensure all machine functions stop when the footswitch is released.

- c. Operate all functions and check all limiting and cut-out switches to ensure proper operation.
- d. Check auxiliary power and ensure proper operation.



IF DELAYED MOVEMENT IS DETECTED IN WIRE ROPE OPERATION, LOWER PLATFORM TO STOWED POSITION, SHUT DOWN MACHINE, AND HAVE WIRE ROPES INSPECTED/SERVICED BY A QUALIFIED JLG MECHANIC. LOOSE OR MISADJUSTED WIRE ROPES COULD RESULT IN SERIOUS INJURY OR DEATH.

2. Check the Boom Control System. Refer to Boom Control System Check Procedure later in this section.
3. From the platform control console:
 - a. Ensure the control console is firmly secured in the proper location.
 - b. Check all guards protecting the switches or locks are in place.
 - c. Ensure all machine functions are disabled when the Emergency Stop Button is pushed in.
 - d. Ensure all machine functions stop when the footswitch is released.

- e. Operate all functions and check all limiting and cut-out switches to ensure proper operation.

WARNING

IF DELAYED MOVEMENT IS DETECTED IN WIRE ROPE OPERATION, LOWER PLATFORM TO STOWED POSITION, SHUT DOWN MACHINE, AND HAVE WIRE ROPES INSPECTED/SERVICED BY A QUALIFIED JLG MECHANIC. LOOSE OR MISADJUSTED WIRE ROPES COULD RESULT IN SERIOUS INJURY OR DEATH.

4. With the platform in the stowed position:
 - a. Drive the machine on a grade, not to exceed the rated gradeability, and stop to ensure the brakes hold.
 - b. Check that the tilt indicator is illuminated to ensure proper operation.
5. Swing the boom over either of the rear tires and ensure that the Drive Orientation indicator illuminates and that the Drive Orientation Override switch must be used for the drive function to operate.
6. Place the machine in Transport Mode. Ensure machine is positioned on a smooth, firm surface and drive machine with boom elevated beyond 3° horizontal. Ensure drive speed is reduced while operating.

Boom Control System Check Procedure

Perform the following check with no load (personnel or material) in the platform from the ground control console.

1. Ensure all axles are fully extended.
2. With the boom fully retracted, raise the boom off the boom rest to horizontal.
3. Position the jib horizontal and platform level.
4. Extend the boom until it stops.
5. Push and hold the Boom Control System Test button. The lighting of the green Boom Control System Calibrated indicator indicates the system is functioning properly. No indicator light or the lighting of the red Boom Control System Warning indicator indicates the system must be repaired by JLG authorized Service Personnel before the machine can be used.

SECTION 2 - USER RESPONSIBILITIES, MACHINE PREPARATION, AND INSPECTION

SkyGuard Function Test

NOTE: Refer to Section 4.13 for additional information on SkyGuard operation.

From the Platform Console in an area free from obstructions:

1. Operate the telescope out function.
2. Activate the SkyGuard sensor:
 - a. **SkyGuard** - Apply approximately 50 lb (222 Nm) of force to yellow bar.
 - b. **SkyGuard - SkyLine** - Press cable to break magnetic connection between the cable and right bracket.
 - c. **SkyGuard - SkyEye** - Put arm or hand in path of sensor beam.
3. Once the sensor has been activated, verify the following conditions:
 - a. Telescope out function stops and telescope in function operates for a short duration.
 - b. The horn sounds.
 - c. If equipped with a SkyGuard beacon, the beacon illuminates.

4. Disengage the SkyGuard sensor, release controls, then recycle the footswitch. Ensure normal operation is available.

NOTE: On machines equipped with SkyLine, reattach magnetic end of the cable to the bracket.

If SkyGuard remains activated after function reversal or cutout, depress and hold the SkyGuard Override Switch to allow normal use of machine functions until the sensor is disengaged.

SECTION 3. MACHINE CONTROLS AND INDICATORS

3.1 GENERAL

NOTICE

THE MANUFACTURER HAS NO DIRECT CONTROL OVER MACHINE APPLICATION AND OPERATION. THE USER AND OPERATOR ARE RESPONSIBLE FOR CONFORMING WITH GOOD SAFETY PRACTICES.

This section provides the necessary information needed to understand control functions.

3.2 CONTROLS AND INDICATORS

NOTE: *The indicator panels use different shaped symbols to alert the operator to different types of operational situations that could arise. The meaning of those symbols are explained below.*



Indicates a potentially hazardous situation, which if not corrected, could result in serious injury or death. This indicator will be red.



Indicates an abnormal operating condition, which if not corrected, may result in machine interruption or damage. This indicator will be yellow.



Indicates important information regarding the operating condition, i.e. procedures essential for safe operation. This indicator will be green with the exception of the capacity indicator which will be green or yellow depending upon platform position.

SECTION 3 - MACHINE CONTROLS AND INDICATORS

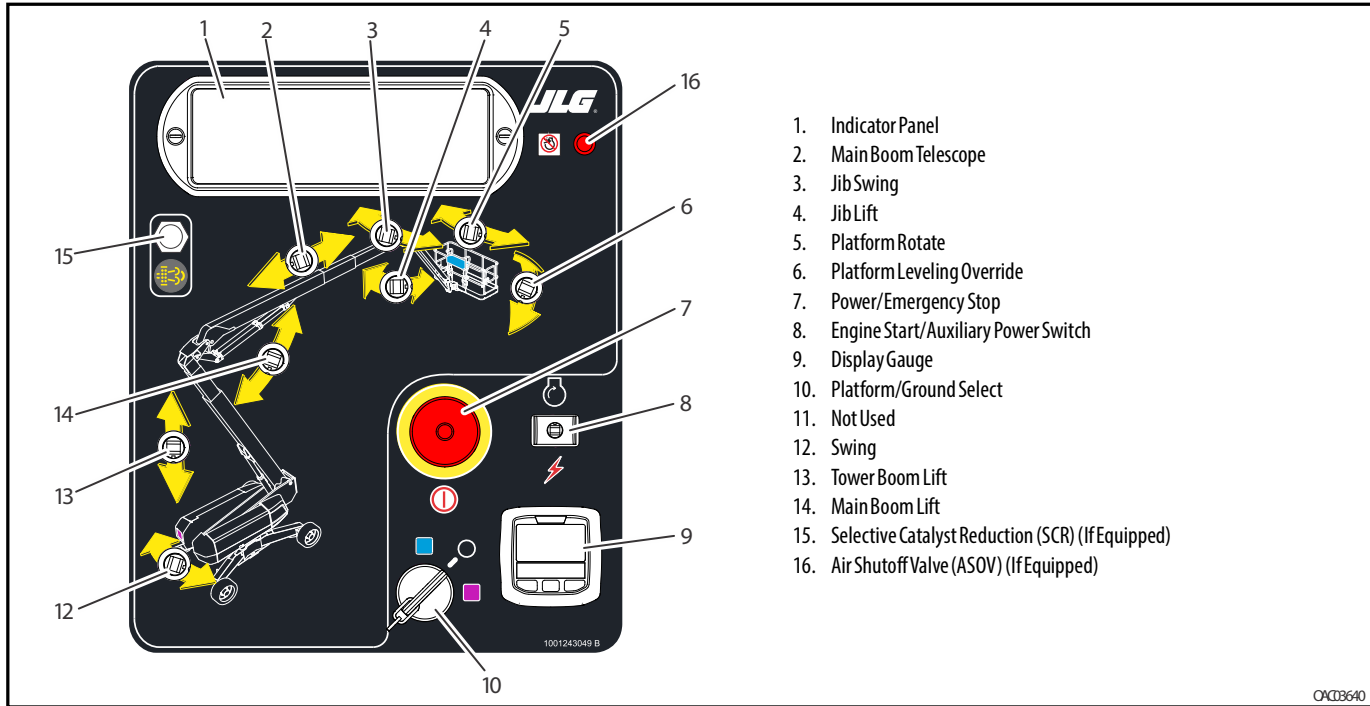
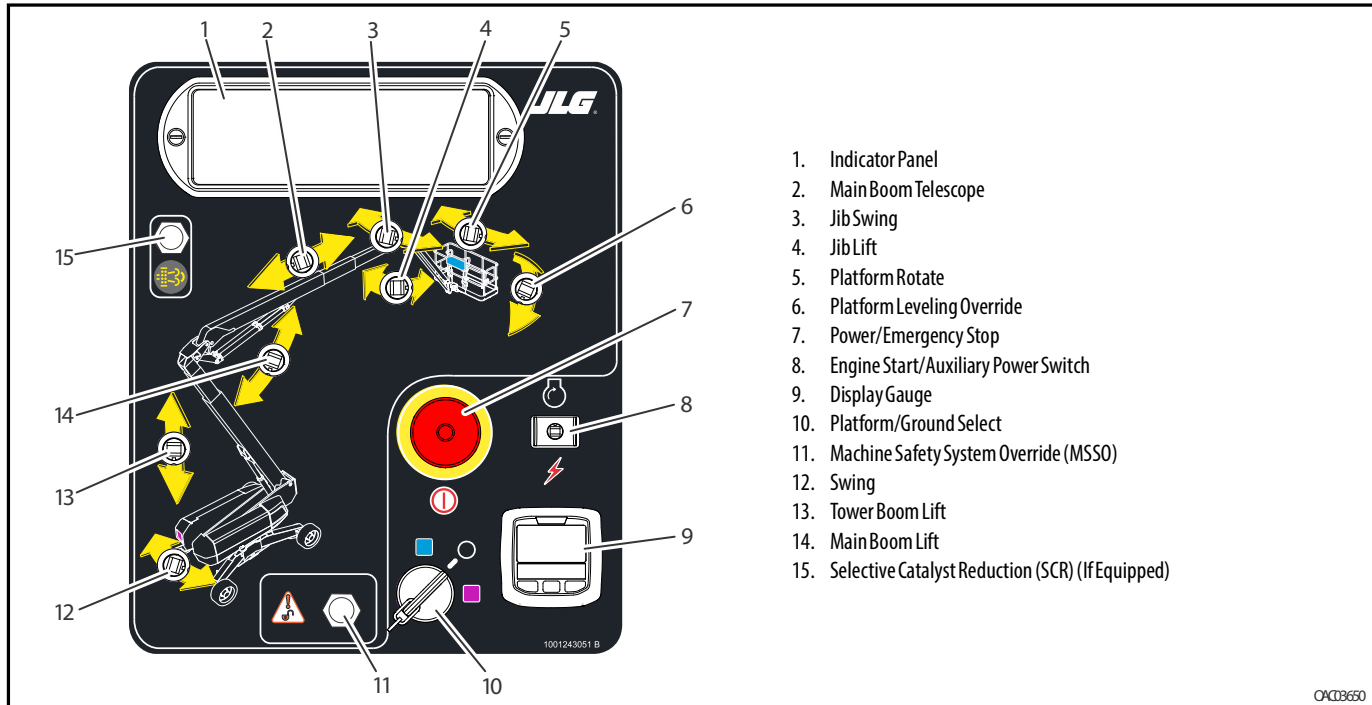

Figure 3-1. Ground Control Console



1. Indicator Panel
2. Main Boom Telescope
3. Jib Swing
4. Jib Lift
5. Platform Rotate
6. Platform Leveling Override
7. Power/Emergency Stop
8. Engine Start/Auxiliary Power Switch
9. Display Gauge
10. Platform/Ground Select
11. Machine Safety System Override (MSSO)
12. Swing
13. Tower Boom Lift
14. Main Boom Lift
15. Selective Catalyst Reduction (SCR) (If Equipped)

Figure 3-2. Ground Control Console with MSSO

SECTION 3 - MACHINE CONTROLS AND INDICATORS

⚠ WARNING

TO AVOID SERIOUS INJURY, DO NOT OPERATE MACHINE IF ANY CONTROL LEVERS OR TOGGLE SWITCHES CONTROLLING PLATFORM MOVEMENT DO NOT RETURN TO THE OFF OR NEUTRAL POSITION WHEN RELEASED.

Ground Control Console

See Figure 3-1., Ground Control Console and Figure 3-2., Ground Control Console with MSSO.

1. Indicator Panel

The Indicator Panel contains indicator lights that signal problem conditions or functions operating during machine operation.

2. Main Boom Telescope

Provides extension and retraction of the main boom.

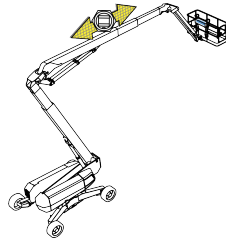

3. Jib Swing

Allows swinging of the jib.

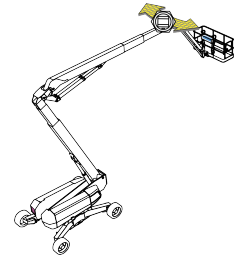

4. Jib Lift

Provides raising and lowering of the jib.

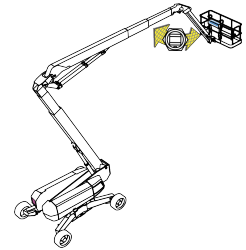

5. Platform Rotate

Provides rotation of the platform.

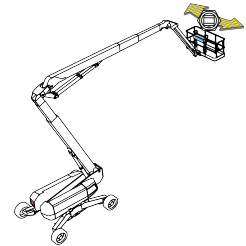

⚠ WARNING

ONLY USE THE PLATFORM LEVELING OVERRIDE FUNCTION FOR SLIGHT LEVELING OF THE PLATFORM. INCORRECT USE COULD CAUSE THE LOAD/OCCUPANTS TO SHIFT OR FALL. FAILURE TO DO SO COULD RESULT IN DEATH OR SERIOUS INJURY.

6. Platform Leveling Override

A three position switch allows the operator to adjust the automatic self leveling system. This switch is used to adjust platform level in situations such as ascending/descending a grade.

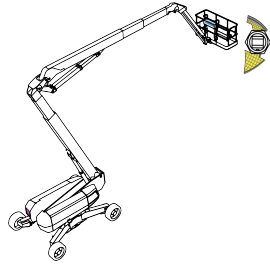

NOTE: *Auxiliary power only works if the engine is not running. Some functions operate in a different manner and at a slower than normal rate because of the reduced hydraulic flow.*

NOTICE

WHEN USING AUXILIARY POWER, DO NOT OPERATE MORE THAN ONE FUNCTION AT A TIME. SIMULTANEOUS OPERATION CAN OVERLOAD THE AUXILIARY PUMP.

⚠ CAUTION

WHEN THE MACHINE IS SHUT DOWN THE POWER/EMERGENCY STOP SWITCH MUST BE POSITIONED TO THE OFF POSITION TO PREVENT DRAINING THE BATTERIES.

7. Power/Emergency Stop Switch

A two-position red mushroom shaped switch supplies power to Platform/Ground Select switch when pulled out (on). When pushed in (off), power is shut off to the Platform/Ground Select switch.

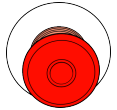

8. Engine Start/ Auxiliary Power Switch /Function Enable

To start the engine, the switch must be held Up until the engine starts.



To use auxiliary power, the switch must be held Down for duration of auxiliary pump use.



9. Display Gauge

Registers engine hours, fuel level (if applicable), and Diagnostic Trouble Codes (DTCs) from both the JLG Control System and the engine control system.



NOTE: *With Platform/Ground Select switch in the center position, power is shut off to controls at both operating consoles.*

SECTION 3 - MACHINE CONTROLS AND INDICATORS

10. Platform/Ground Select Switch

A three position, key operated switch supplies power to the platform control console when positioned to Platform. With the switch key positioned in the Ground position, power is shut off to platform and only ground controls are operable.

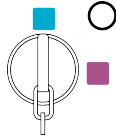

11. Machine Safety System Override (MSSO) (If Equipped)

Provides emergency override of function controls that are locked out as in the event of Load Sense System activation.



12. Swing

Provides 360 degrees continuous turntable rotation.

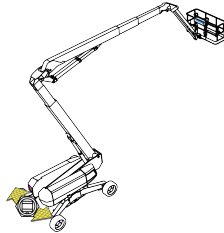

13. Tower Boom Lift

Provides raising and lowering of the tower boom.

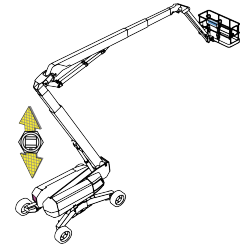

14. Main Boom Lift

Provides raising and lowering of the main boom.

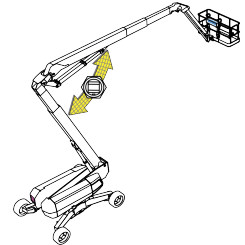

- 15.** Selective Catalyst Reduction (SCR) Button
(If Equipped)

The Selective Catalyst Reduction (SCR) push button is used to initiate the Standstill Cleaning mode.



- 16.** Air Shutoff Valve (ASOV) (If Equipped)

The red LED ASOV light indicates when the valve has been actuated.



SECTION 3 - MACHINE CONTROLS AND INDICATORS

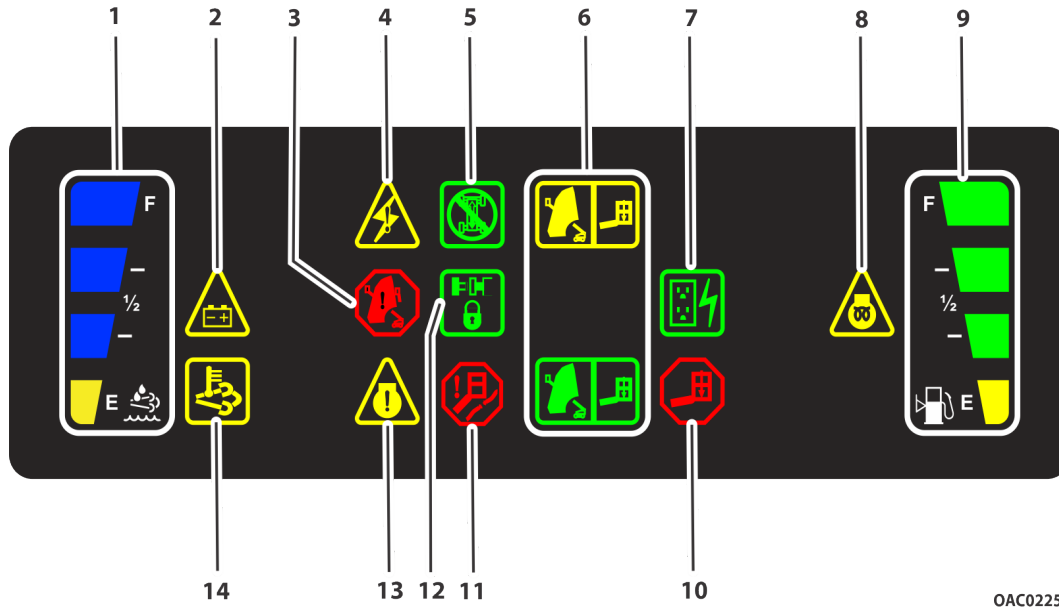

OAC02250

- | | | |
|---|----------------------------|---------------------------|
| 1. Diesel Exhaust Fluid Indicator (DEF) | 6. Capacity Zone Indicator | 10. Platform Overload |
| 2. Battery Charge | 7. Generator | 11. Wire Rope Indicator |
| 3. Boom Control System Warning | 8. Glow Plug | 12. Axles Set |
| 4. System Distress | 9. Fuel Level | 13. Engine Error |
| 5. Drive/Steer Disable | | 14. Emissions Temperature |

Figure 3-3. Ground Control Indicator Panel

Ground Control Indicator Panel

(See Figure 3-3., Ground Control Indicator Panel)

1. Diesel Exhaust Fluid (DEF) Indicator

The DEF level indicator shows the fluid level in the tank.

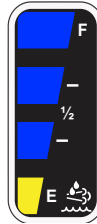

2. Battery Charge Indicator

Indicates a problem in the battery or charging circuit, and service is required.



3. Boom Control System Warning Indicator

Indicates the platform is outside the operating area and operation of certain boom functions may be disabled (i.e. lift, telescope). Attempts to use the disabled functions cause the indicator to flash and an alarm to sound. Immediately return the platform to the ground. If the indicator remains lit a boom control system fault or failure has been detected. If a failure is discovered,



4. System Distress Indicator

the system must be repaired by a JLG factory trained technician before the machine can be used.



The light indicates that the JLG Control System has detected an abnormal condition and a Diagnostic Trouble Code has been set in the system memory. Refer to the Service Manual for instructions concerning the trouble codes and trouble code retrieval.

The system distress indicator light will illuminate for 2-3 seconds when the key is positioned to the ON position to act as a self test.

5. Drive and Steer Disable Indicator

Indicates the Drive and Steer Disable function has been activated.



6. Capacity Zone Indicator

Indicates the platform capacity zone for the current position of the platform. Restricted capacities are permitted at restricted platform positions (shorter boom lengths and higher boom angles).

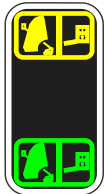

SECTION 3 - MACHINE CONTROLS AND INDICATORS

NOTE: Refer to the capacity decals on the machine for restricted and unrestricted platform capacities.

7. AC Generator Indicator

Indicates the generator is in operation.



8. Glow Plug Indicator

Indicates the glow plugs are on. The glow plugs are automatically turned on with the ignition circuit and remain on for approximately seven seconds. Start the engine only after the light goes out.



9. Fuel Level Indicator

Indicates the level of the fuel in the fuel tank.

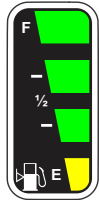

10. Platform Overload Indicator

Indicates the platform has been overloaded.



11. Wire Rope Indicator

When illuminated, the light indicates the wire ropes are loose or broken and must be repaired or adjusted prior to use.



12. Axles Set Indicator

Indicates the axles are fully extended. The indicator will flash as the axles are extending or retracting and be solid when fully extended. The indicator icon will go out when the axles are fully retracted.



13. Engine Error Indicator

Indicates a fault with the engine and service is required.



14. Emissions Temperature Warning Indicator

Icon illuminates when the engine emissions control sensor reaches a high temperature.



Ground Control Console Display Gauge - Machines using Diesel Exhaust Fluid (DEF)

(See Figure 3-7., Ground Control Console Display Gauge)

The Display Gauge shows engine hours, fuel level (if applicable), and Diagnostic Trouble Codes (DTCs) from both the JLG Control System and the engine control system. During machine start up, with no active DTCs in the control system, the splash screen will show for 3 seconds and then switch to main screen. If there is an active DTC while powering up the machine, the splash screen will show for 3 seconds, and then launch the Diagnostics Screen. The indicator lamp will light when there is an active DTC in the Fault Log.



Figure 3-4. Splash Screen

SECTION 3 - MACHINE CONTROLS AND INDICATORS

The Diagnostic Screen will show active and inactive faults from the JLG Control System on the screen. An asterisk (*) will be displayed to show active faults.

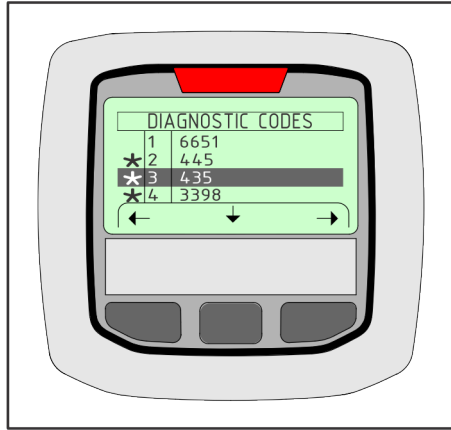

Figure 3-5. Diagnostic Screen

The Engine Diagnostics Screen will show SPN (Suspect Parameter Number), FMI (Failure Mode Identifier), and Occurrence count information. Engine SPN text is not scrollable. If there is more than one engine trouble code, the operator must exit from the Engine DTC Screen to see other SPN and FMI information.

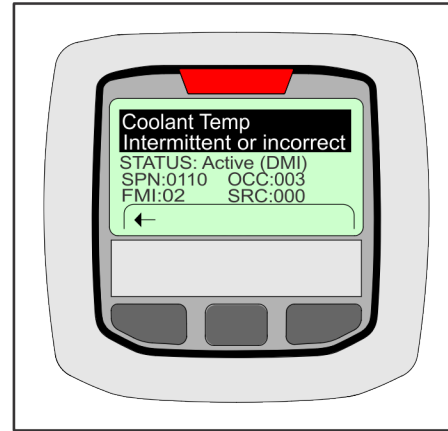

Figure 3-6. Engine Diagnostic Screen

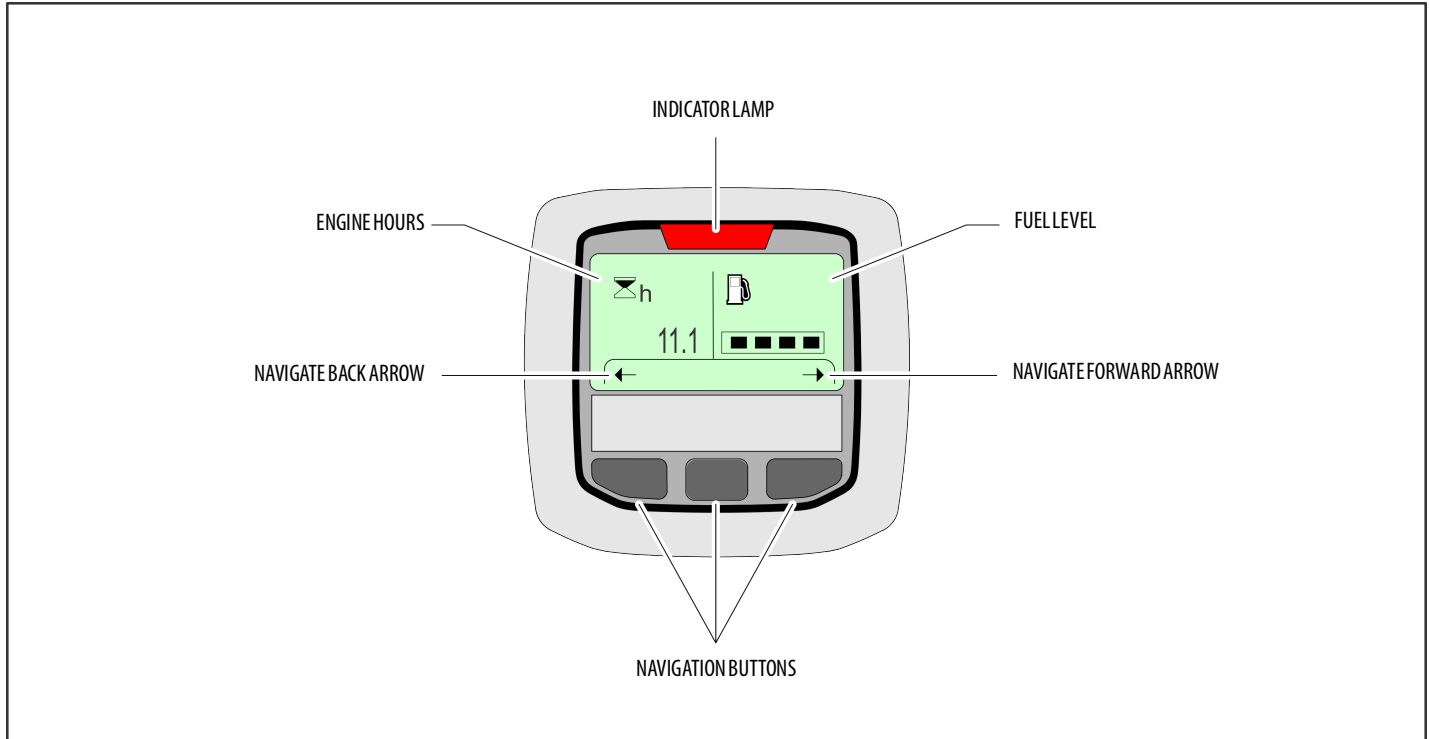
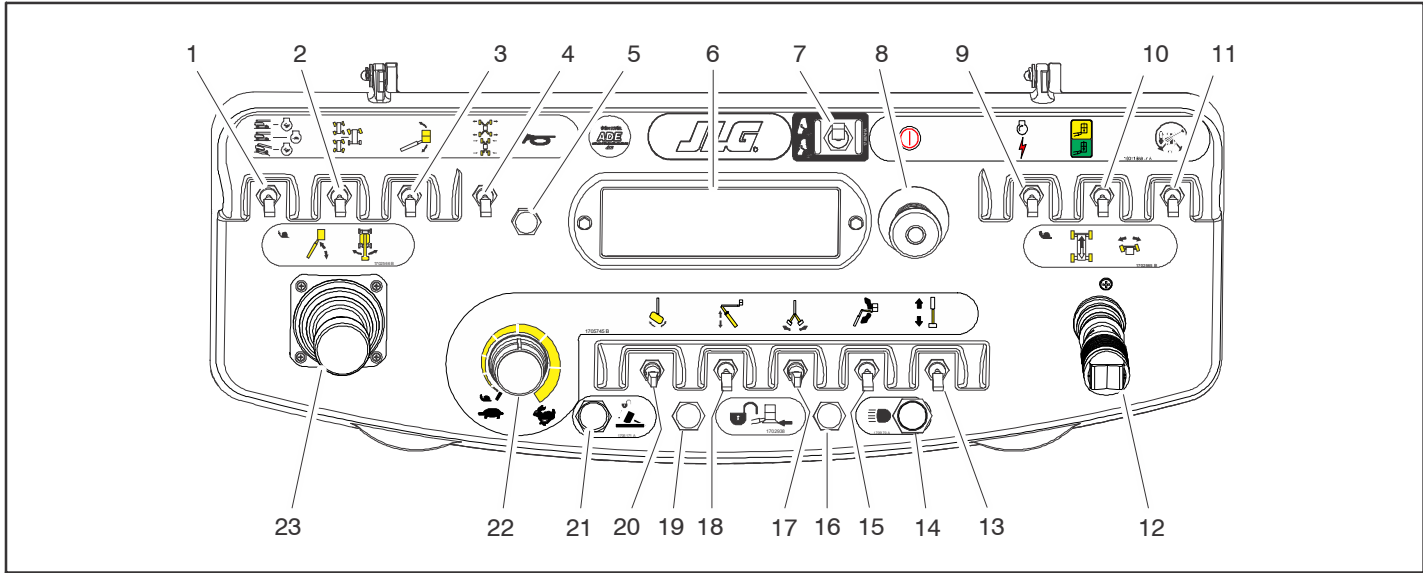

Figure 3-7. Ground Control Console Display Gauge

SECTION 3 - MACHINE CONTROLS AND INDICATORS



- | | | | |
|-------------------------------|--------------------------------|---|-----------------------------------|
| 1. Drive Speed/Torque Select | 7. Boom Control Select | 13. Main Telescope | 18. Tower Boom Lift |
| 2. Steer Select | 8. Power/Emergency Stop | 14. Lights/SkySense Mute | 19. Soft Touch/SkyGuard Indicator |
| 3. Platform Leveling Override | 9. Start/Auxiliary Power | 15. Jib Lift | 20. Platform Rotate |
| 4. Axle Extend/Retract | 10. Capacity Select | 16. Soft Touch/SkyGuard /SkySense
Override | 21. Jib Stow Override |
| 5. Horn | 11. Drive Orientation Override | 17. Jib Swing | 22. Function Speed Control |
| 6. Indicator Panel | 12. Drive/Steer | | 23. Main Lift/Swing |

Figure 3-8. Platform Control Console

Platform Console

(See Figure 3-8., Platform Control Console)

⚠ WARNING

TO AVOID SERIOUS INJURY, DO NOT OPERATE MACHINE IF ANY CONTROL LEVERS OR TOGGLE SWITCHES CONTROLLING PLATFORM MOVEMENT DO NOT RETURN TO THE OFF OR NEUTRAL POSITION WHEN RELEASED.

1. Drive Speed/Torque Select

The machine has a three position switch - The forward position gives maximum drive speed. The back position gives maximum torque for rough terrain and climbing grades. The center position allows the machine to be driven as quietly as possible.

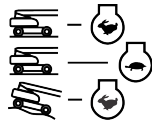

2. Steer Select

The action of the steering system is operator selectable. The center switch position gives conventional front wheel steering with the rear wheels unaffected. This is for normal driving at maximum speeds. The forward position is for "crab" steering. When in this mode both front and rear axles steer in the same direction, which

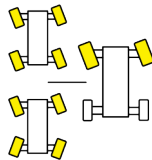

allows the chassis to move sideways as it goes forward. This can be used for positioning the machine in aisle ways or close to buildings. The back switch position is for "coordinated" steering. In this mode the front and rear axles steer in the opposite directions to produce the tightest turning circle for maneuvering in confined areas.

⚠ WARNING

ONLY USE THE PLATFORM LEVELING OVERRIDE FUNCTION FOR SLIGHT LEVELING OF THE PLATFORM. INCORRECT USE COULD CAUSE THE LOAD/OCCUPANTS TO SHIFT OR FALL. FAILURE TO DO SO COULD RESULT IN DEATH OR SERIOUS INJURY.

3. Platform Leveling Override

A three position switch allows the operator to adjust the automatic self leveling system. This switch is used to adjust platform level in situations such as ascending/descending a grade.

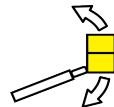

4. Axle Extend/Retract

Allows the operator to extend or retract the axles. The axles can only be extended or retracted while the machine is being driven forward or reverse.

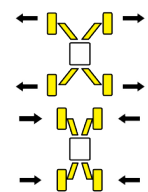

SECTION 3 - MACHINE CONTROLS AND INDICATORS

5. Horn



A push-type Horn switch supplies electrical power to an audible warning device when pressed.

6. Indicator Panel

The LED Indicator Panel contains indicator lights that signal problem conditions or functions operating during machine operation.

Within about 2 seconds of pulling the Power/Emergency Stop switch out, the machine will perform a diagnostic check of the various electrical circuits, and if everything is OK, the platform alarm will beep once. During this time the lights on the indicator panel will also illuminate momentarily as a bulb check.

7. Boom Control Select

Automatic Mode:

When the Boom Control is positioned to Automatic, lift and telescope movements are coordinated by the JLG control system and the automatic platform leveling feature is active during lift, telescope, swing, and drive movements.

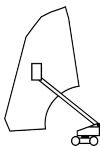

NOTE:

- While operating lift up, the boom may also telescope out.
- While operating lift down, the boom may also telescope in.
- While operating swing or drive, the boom may lift up or lift down.
- While operating telescope in, the boom may lift down when at high boom angles and the creep light is flashing.

Manual Mode:

When the boom control is positioned to Manual, lift and telescope movements are controlled separately by the operator and the automatic platform leveling feature is active only during lift functions.



NOTE:

When positioned to Manual, boom functions will be stopped when the envelope limits are reached. When this occurs, operate a different function or select the automatic position.

NOTE:

Depending upon the angle of the chassis and the angle of the boom, swing left or swing right may be disallowed while in the Manual mode. The BCS light will illuminate and further attempts to swing in the disallowed direction will cause the BCS to flash. When this occurs the only choices are to swing in the opposite direction or switch to automatic mode.

8. Power/Emergency Stop

A two-position red mushroom shaped switch supplies power to Platform Controls when pulled out (on). When pushed in (off), power is shut off to the platform controls.

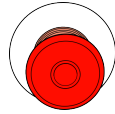

9. Start/Auxiliary Power

When pushed forward, the switch energizes the starter motor to start the engine.



When pushed back, it energizes the electrically operated hydraulic pump, when actuated. (Switch must be held on for duration of auxiliary pump use.)The auxiliary pump functions to provide sufficient oil flow to operate the basic machine functions should the main pump or engine fail. The auxiliary pump will operate all functions except Drive/Steer and Axles.



10. Capacity Select

This switch allows the operator to select between an operating envelope with a 600 lb (272 kg for ANSI markets and 270 kg for CE and Australia markets) capacity restriction or a 1000 lb (454 kg for ANSI markets and 450 kg for CE and Australia markets) capacity restriction.

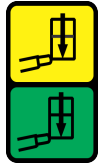

11. Drive Orientation Override

When the boom is swung over the rear tires or further in either direction, the Drive Orientation indicator will illuminate when the drive function is selected. Push and release the switch, and within 3 seconds move the Drive/Steer control to activate drive or steer. Before driving, locate the black/white orientation arrows on both the chassis and the platform controls. Move the drive controls in a direction matching the directional arrows for the intended direction of travel.



SECTION 3 - MACHINE CONTROLS AND INDICATORS

NOTE: To operate the Drive Joystick, pull up on the locking ring below the handle.

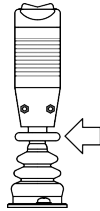

NOTE: The DRIVE control levers are spring-loaded and will automatically return to neutral (Off) position when released.

12. Drive/Steer

Push forward to drive forward, pull back to drive in reverse. Steering is accomplished via a thumb-activated rocker switch on the end of the steer handle.

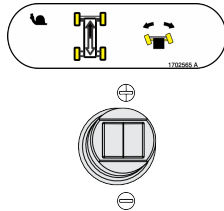

13. Main Telescope

Provides extension and retraction of the main boom.

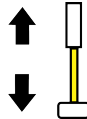

14. Lights/SkySense Mute (If Equipped)

Operates accessory light packages if the machine is so equipped.



If machine is equipped with SkySense, the switch will mute the SkySense speakers.



15. Jib Lift

Provides raising and lowering of the jib.

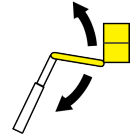

16. Soft Touch/SkyGuard/SkySense Override Switch

For machines equipped with SkyGuard:

The SkyGuard override switch enables functions cut out by the Skyguard system to be operated again, allowing the operator to resume use of machine functions.



For machines equipped with both SkyGuard and Soft Touch:

The switch operates like the SkyGuard override switch as described above.

The switch also enables the functions cut out by the Soft Touch system to operate again at creep speed, allowing the operator to move the platform away from the obstacle that caused the shut-down situation.



For machines equipped with both SkyGuard and SkySense:

The switch operates like the SkyGuard override switch as described above.

The switch also enables the functions cut out by the SkySense system to operate again at creep speed, allowing the operator to move the platform closer to the obstacle that caused the shut-down situation if desired.



NOTE: *The Jib Swing function is not operable when the Capacity Select control is in the 1000 lb (454 kg for ANSI markets and 450 kg for CE and Australia markets) position.*

17. Jib Swing

Allows the operator to swing the jib to the left or right.

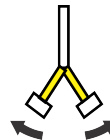

18. Tower Boom Lift

Allows raising and lowering of the tower boom by activating the tower lift and telescope cylinders as dictated by the Boom Control System.

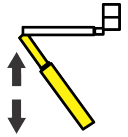

19. Soft Touch/SkyGuard Indicator

Indicates the Soft Touch bumper is against an object or the SkyGuard sensor has been activated. All controls are cut out until the override button is pushed. For Soft Touch, controls are then active in the Creep Mode or for SkyGuard, controls will work normally.

20. Platform Rotate

Allows the operator to rotate the platform to the left or right.

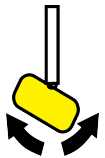

21. Jib Stow Override

Allows the operator to swing the jib to the right past the electronic stop to stow the jib beside the boom for transport.



SECTION 3 - MACHINE CONTROLS AND INDICATORS

22. Function Speed Control

This control knob affects the speed of Telescope, Jib Swing, Jib Lift, Tower Boom Lift, and Platform Rotate functions.



NOTE: During platform rotation, a speed difference may not be noticeable to the operator.

Turning the knob all the way counterclockwise until it clicks puts the machine into Creep Mode. Creep Mode puts the functions listed above, as well as the Drive/Steer and Main Lift/Swing functions into the slowest speed setting.

NOTE: To operate the Main Boom Lift/Swing joystick, pull up on the locking ring below the handle.

NOTE: The Main Boom Lift/Swing joystick is spring loaded and will automatically return to neutral (off) position when released.

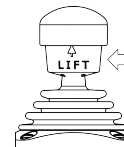

23. Main Lift/Swing Controller

Provides Main Lift and Swing. Push forward to lift up, pull backward to boom down. Move right to swing right, move left to swing left.

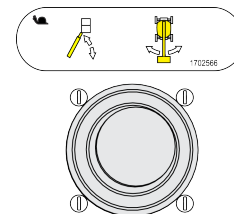

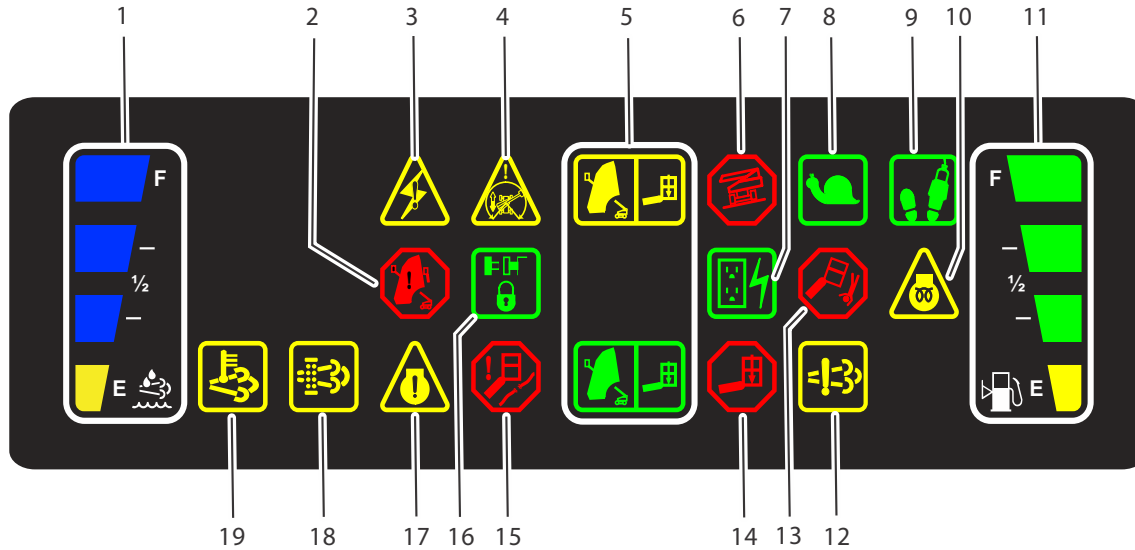

OAC02290

- | | | | | |
|---|----------------------------|-----------------------|-----------------------|---|
| 1. Diesel Exhaust Fluid Indicator (DEF) | 5. Capacity Zone Indicator | 9. Footswitch | 13. Level System | 17. Engine Error |
| 2. Boom Control System Warning | 6. Tilt Alarm Warning | 10. Glow Plug | 14. Platform Overload | 18. Diesel Particulate Filter Indicator |
| 3. System Distress | 7. Generator | 11. Fuel Level | 15. Wire Rope Service | 19. Emissions Temperature |
| 4. Drive Orientation | 8. Creep | 12. Emissions Failure | 16. Axles Set | |

Figure 3-9. Platform Control Indicator Panel

Platform Control Indicator Panel

(See Figure 3-9., Platform Control Indicator Panel)

1. Diesel Exhaust Fluid (DEF) Indicator

The DEF level indicator shows the fluid level in the tank.

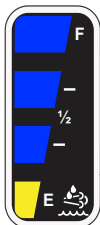

2. Boom Control System Warning Indicator

Indicates the platform is outside the operating area and operation of certain boom functions may be disabled (i.e. lift, telescope). Attempts to use the disabled functions cause the indicator to flash and an alarm to sound. Immediately return the platform to the ground. If the indicator remains lit, a boom control system fault or failure has been detected. If a failure is discovered, the system must be repaired by a JLG factory trained technician before the machine can be used.



3. System Distress Indicator

The light indicates that the JLG Control System has detected an abnormal condition and a Diagnostic Trouble Code has been set in the system memory. Refer to the Service Manual for instructions concerning the trouble codes and trouble code retrieval.



4. Drive Orientation Indicator

When the boom is swung beyond the rear drive tires or further in either direction, the Drive Orientation indicator will illuminate when the drive function is selected. This is a signal for the operator to verify that the drive control is being operated in the proper direction (i.e. controls reversed situations).



5. Capacity Zone Indicator

Indicates the maximum platform capacity zone for the current position of the platform. Restricted capacities are permitted at restricted platform positions (shorter boom lengths and higher boom angles).



NOTE: Refer to the capacity decals on the machine for restricted and unrestricted platform capacities.

6. Tilt Warning Light and Alarm

This red illuminator indicates that the chassis is on a slope. If the boom is above horizontal and the machine is on a slope, the tilt alarm warning light will illuminate, an alarm will sound, available functions are placed in CREEP speed, and drive is cut out in direction of travel. Drive in the opposite direction may be allowed under certain conditions.



Tilt Angle	Market
5°	All Markets

⚠ WARNING

IF TILT WARNING LIGHT IS ILLUMINATED WHEN BOOM IS RAISED OR EXTENDED, RETRACT AND LOWER TO BELOW HORIZONTAL THEN REPOSITION MACHINE SO THAT IT IS WITHIN THE LIMITS OF THE MAXIMUM OPERATING SLOPE BEFORE EXTENDING BOOM OR RAISING BOOM ABOVE HORIZONTAL.

NOTE: *When the tilt sensor alarm is activated the Drive function will be disabled if the boom is elevated above horizontal.*

7. AC Generator Indicator

Indicates the generator is in operation.



8. Creep Speed Indicator

When the Function Speed Control is turned to the creep position, the indicator acts as a reminder that all functions are set to the slowest speed.



9. Footswitch/Enable Indicator

To operate any function, the footswitch must be depressed and the function selected within seven seconds. The enable indicator shows that the controls are enabled. If a function is not selected within seven seconds, or if a seven second lapse between ending one function and beginning the next function, the enable light will go out and the footswitch must be released and depressed again to enable the controls.



Releasing the footswitch removes power from all controls and applies the drive brakes.

⚠ WARNING

TO AVOID SERIOUS INJURY, DO NOT REMOVE, MODIFY OR DISABLE THE FOOTSWITCH BY BLOCKING OR ANY OTHER MEANS.

SECTION 3 - MACHINE CONTROLS AND INDICATORS

10. Glow Plug Indicator

Indicates the glow plugs are operating. After turning on ignition, wait until light goes out before cranking engine.



11. Fuel Level Indicator

Indicates the level of the fuel in the fuel tank.

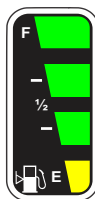

12. Engine Emissions System Failure Indicator

Icon illuminates when there is a fault with the Emissions After Treatment system.



13. Level System Indicator

Indicates a fault in the electronic leveling system. The fault indicator will flash and an alarm will sound. All functions will default to creep if the boom is extended past transport mode or elevated more than 8 degrees above horizontal.



14. Platform Overload Indicator

Indicates the platform has been overloaded.



15. Wire Rope Service

When illuminated, the light indicates the wire ropes are loose or broken and must be repaired or adjusted prior to use.



16. Axles Set Indicator

Indicates the axles are fully extended. The indicator will flash as the axles are extending or retracting and be solid when fully extended. The indicator icon will go out when the axles are fully retracted.



17. Engine Error Indicator

Indicates a fault with the engine and service is required.



18. Diesel Particulate Filter (DPF) Indicator

Icon will illuminate when standstill exhaust system cleaning is required.



19. Emissions Temperature Indicator

Icon illuminates when the engine emissions control sensor reaches a high temperature.



SECTION 4. MACHINE OPERATION

4.1 DESCRIPTION

This machine is a mobile elevating work platform used to position personnel, along with their necessary tools and materials at work locations.

The primary operator control console is in the platform. From this control console, the operator can drive and steer the machine in both forward and reverse directions. The operator can raise or lower the upper or lower boom or swing the boom to the left or right. Standard boom swing is 360 degree continuous left and right of the stowed position. The machine has a Ground Control Console which will override the Platform Control Console. Ground Controls operate all functions except drive and steer. Except for performing inspections and the Function Check, the ground controls are to be used in an emergency to lower the platform to the ground should the operator in the platform be unable to do so.

4.2 HYDRAULIC SYSTEM WARM UP

The control system monitors the hydraulic system in extremely cold temperatures and provides optimal performance by automatically limiting the function speeds of the high demand functions. The warm up mode automatically shuts off when system oil reaches allowable temperatures.

While the system is cold and in the warm up mode, the tower lift, main lift, and main telescope functions are limited to creep speeds and is indicated to the operator by flashing the creep light on the platform control panel.

Functions being operated when the warm up mode turns off will remain in the creep speed until the function is re-initiated.

4.3 BOOM OPERATING CHARACTERISTICS AND LIMITATIONS

Capacities

Raising boom above horizontal with or without any load in platform, is based on the following criteria:

1. Machine is positioned on a smooth, firm surface within the limits of the maximum operating slope.
2. Axles are fully extended.
3. Load is within manufacturers rated design capacity.
4. All machine systems are functioning properly.
5. Machine is as originally equipped from JLG.

Envelope Control System

The Envelope Control System is the primary means of controlling the working positions of the tower and main boom within the stability and structural requirements of the machine. The main boom must be controlled in maximum angle and minimum angle to avoid entering a position that could compromise backward stability and avoid main boom to tower boom interference. The main boom envelope does not change based on tower boom angle. The tower boom must be controlled by permitting only

specific combinations of tower length and tower angle to avoid entering a position that could compromise forward and backward stability.

Recognized faults within this system will result in control by the Electrical Retrieval System, reduced function speeds, and Boom Control System (BCS) warning light illumination. After retrieval the boom will be restricted from leaving the transport position until the fault is resolved.

Boom position violations outside of the allowable envelope will result in reduced function speeds, BCS warning light illumination, and restriction of functions. The platform alarm will sound and the BCS light will flash with attempts to operate restricted functions.

Violations of the tower envelope can be corrected by actuating either of the tower lift up or tower lift down directions of the tower lift switch regardless of the direction of the violation. The control system will telescope or lift the tower to correct the tower position.

The restricted functions due to backward tower envelope violations are disallowing automatic tower lift down with tower lift down commands, automatic tower telescope out with tower lift up commands, main lift up and down, main telescope in, jib, swing, drive and steer.

The restricted functions due to main boom envelope violations related to backward reach are disallowing main lift up, main telescope in, swing, drive, and steer.

The restricted functions due to forward tower envelope violations are disallowing automatic tower lift up with tower lift up commands, automatic tower telescope in with tower lift down commands, main lift up and down, main telescope out, jib, swing, drive and steer.

The restricted functions due to main boom envelope violations related to forward reach are disallowing main lift down, main telescope out, swing, drive and steer.

Tower Path Control System

The Tower Path Control System uses the envelope control sensors to enhance the control of the tower boom and is used as an integral part of the envelope control system. Both the ground and platform control panels use one function switch to control the tower. User commands for tower lift up or tower lift down cause the control system to introduce the correct combination of tower telescope and tower lift for the tower boom to follow a pre-described path or trajectory of the tower nose.

The tower path is a fixed relationship of tower length and tower angle (relative to gravity) and is constant regardless of main boom angle.

Automatic Boom Control System

The Automatic Boom Control System uses the envelope control sensors to enhance the control of the main boom during tower lift functions. Due to the mechanical joining of the main and tower booms, changes in tower boom angle would normally have an opposite effect on the main boom angle. To compensate for this, when the tower is raised the control system automatically introduces main lift up and when the tower is lowered the control system automatically introduces main lift down. This keeps the platform moving in the same direction as the Operator command and to increase user efficiency during tower lift functions.

During tower lift up or tower lift down movements, the control system will maintain the angle of the main boom (relative to gravity) read at the start of the tower lift command or as read at the conclusion of main lift during combined tower and main lift commands.

Slow Down System

To reduce the machine dynamics and improve operator control, the control system uses the envelope control sensors to slow down the tower lift up and tower lift down at the top of the tower path and to slow down main lift up and main lift down function speeds as the minimum and maximum angles of the working envelope are approached, and main boom telescope out as the edge of the envelop is approached. The control system indicates to the operator this introduction of slow down by flashing the creep light on the platform display panel. This applies to both platform and ground controls, however, no indication is made on the ground control panel.

Controlled Boom Angle System

The Controlled Boom Angle System uses the envelope control sensors to enhance the control of the boom by minimizing the interaction of swing and drive functions with the envelope edges. This interaction is due to two factors. First, the envelope is controlled relative to gravity regardless of ground slope and second, the turntable/boom mounting is affected by swing and drive functions when the ground slope varies. This can cause the boom position to vary within the envelope or even violate the envelope edges when swinging or driving without intentionally moving the boom. The controlled boom angle system minimizes this effect by automatically introducing either the tower or main

boom lift up or down during swing and drive commands to maintain a constant boom angle relative to gravity.

When the tower is below the tower transport angle and the main boom is greater than 8° with respect to gravity, the angle of the main boom is controlled. When the tower is above the tower transport angle, the angle of the tower is controlled regardless of main boom control select switch selection.

Controlled boom angle is disabled with any envelope violation or fault and can be turned off with the manual position of the boom control select switch.

Swing Speed Proportioning

Swing Speed Proportioning uses the envelope control sensors to improve the comfort, speed and control of the turntable swing function. Turntable swing speed is increased as the distance of the platform to the center of rotation is decreased and when the tower boom is lowered in angle. This results in approximately constant platform speeds regardless of boom position.

Swing speed proportioning is disabled with any envelope sensor's fault. Disabling of swing speed proportioning will default to the slowest swing speed setting.

Platform Load Sensing System (LSS)

The Platform Load Sensing System provides the platform capacity to the control system.

If the LSS system senses an overload condition, boom functions will be disabled, the overload indicator is illuminated at both control stations, and the overload alarm will sound. Reduce the weight in the platform to not exceed the rated workload indicated on the capacity decal, then the controls will work again.

Stability

Machine stability is based on two (2) conditions which are called FORWARD and BACKWARD stability. The machine's position of least FORWARD stability is shown in Figure 4-1., and its position of least BACKWARD stability is shown in Figure 4-2.

WARNING

TO AVOID FORWARD OR BACKWARD TIPPING, DO NOT OVERLOAD MACHINE OR OPERATE THE MACHINE BEYOND THE LIMIT OF THE MAXIMUM OPERATING SLOPE.

SECTION 4 - MACHINE OPERATION

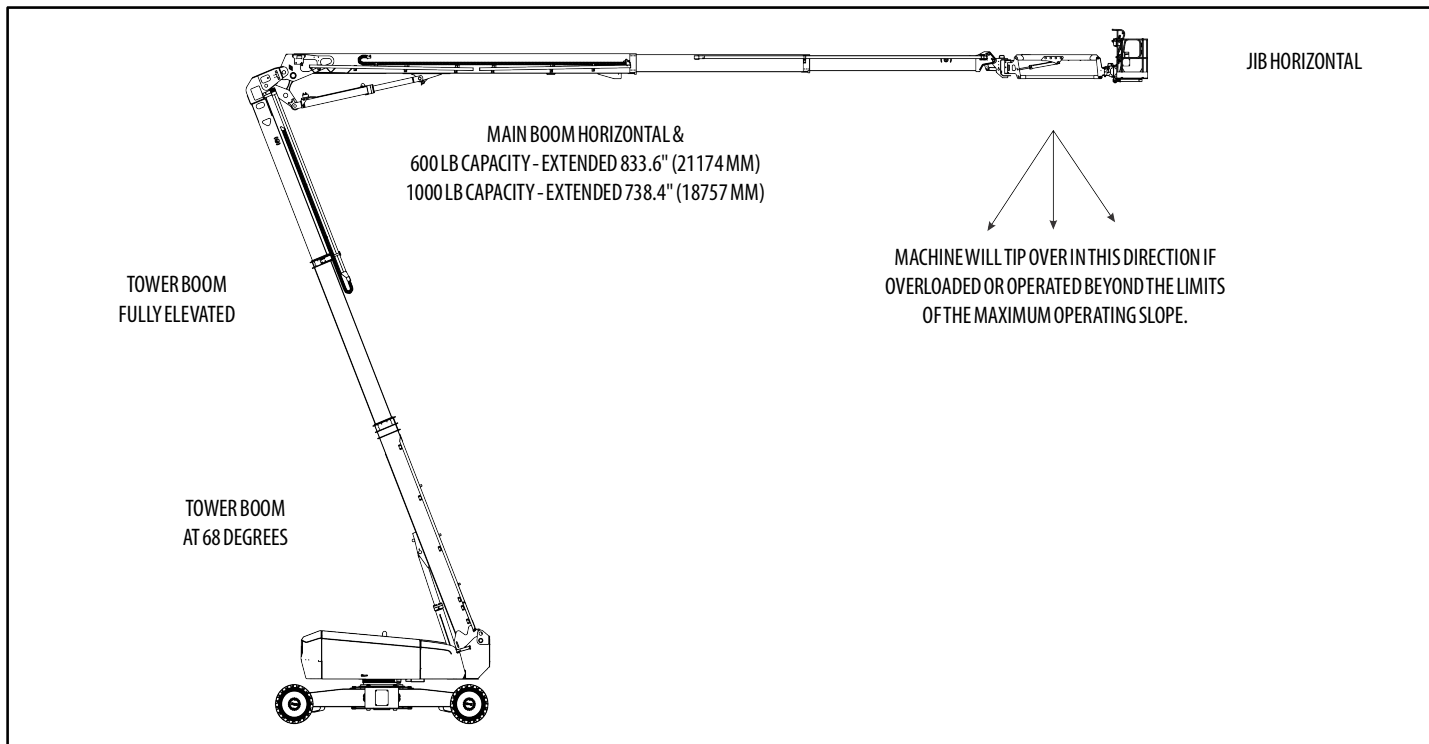

Figure 4-1. Position of Least Forward Stability

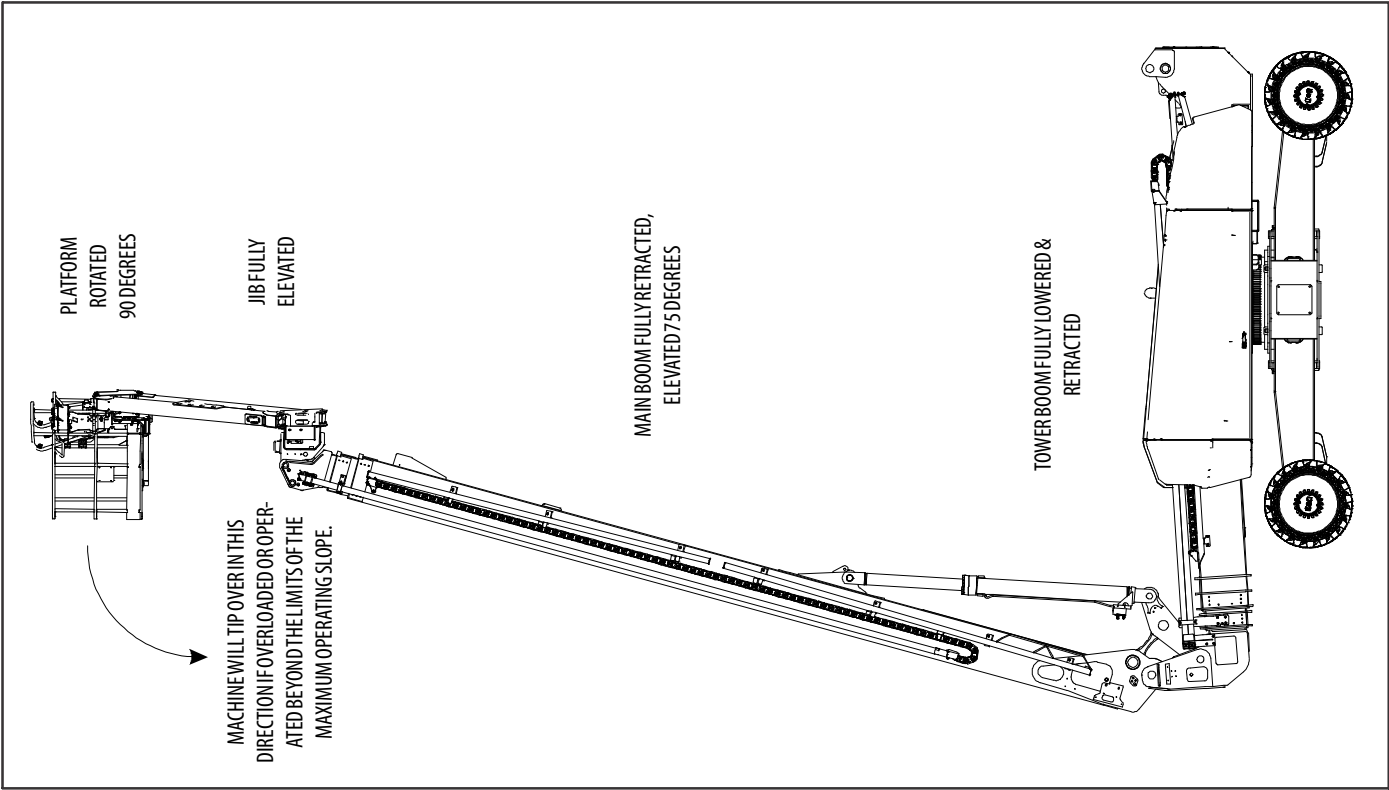
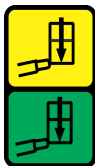

Figure 4-2. Position of Least Backward Stability

SECTION 4 - MACHINE OPERATION

4.4 CAPACITY SELECT

The Boom Control System allows the operator to select operation in a 600 lb (272 kg for ANSI markets and 270 kg for CE and Australia markets) capacity restriction envelope or a 1000 lb (454 kg for ANSI markets and 450 kg for CE and Australia markets) capacity restriction envelope. The operator selects the desired capacity restriction by positioning the Capacity Select switch on the platform console. The Capacity Indicator shows the capacity selected, and both capacity lights will flash and an alarm sound if the platform is out of the selected capacity range.



NOTE: Operation in the 1000 lb (454 kg for ANSI markets and 450 kg for CE and Australia markets) envelope requires the jib to be straight with the boom.

4.5 ENGINE OPERATION

NOTE: When operating a machine at high altitudes, a decrease in machine performance may occur due to a decrease in air density.

NOTE: When operating a machine at high ambient temperatures, a decrease in machine performance and an increase in engine coolant temperature may occur.

NOTE: Contact JLG Customer Service for operation under abnormal conditions.

NOTE: Initial starting should always be performed from the Ground Control console.

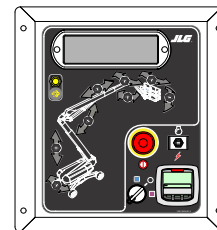

Starting Procedure

CAUTION

IF ENGINE FAILS TO START PROMPTLY, DO NOT CRANK FOR AN EXTENDED TIME. SHOULD ENGINE FAIL TO START AGAIN, ALLOW STARTER TO “COOL OFF” FOR 2-3 MINUTES. IF ENGINE FAILS AFTER SEVERAL ATTEMPTS, REFER TO ENGINE MAINTENANCE MANUAL.

NOTE: After turning on ignition, operator must wait until glow plug indicator light goes out before cranking engine.



1. Turn key of Platform/Ground Select switch to the Ground position.



2. Pull the Power/Emergency Stop switch out.

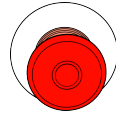

3. Push the Engine Start switch until engine starts.



6. Pull out the Ground Console Power/Emergency Stop switch to provide power to the platform controls.

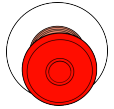

7. From the Platform, pull the Power/Emergency Stop switch out.

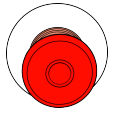

8. Push the Engine Start switch until engine starts.



CAUTION

ALLOW ENGINE TO WARM-UP FOR A FEW MINUTES AT LOW SPEED BEFORE APPLYING ANY LOAD.

4. After engine has had sufficient time to warm up, shut engine off.
5. Turn Platform/Ground Select switch to Platform.



NOTE: Footswitch must be in released (up) position before starter will operate. If starter operates with footswitch in the depressed position, DO NOT OPERATE MACHINE.

Shutdown Procedure

⚠ CAUTION

IF AN ENGINE MALFUNCTION CAUSES AN UNSCHEDULED SHUTDOWN, DETERMINE THE CAUSE AND CORRECT IT BEFORE RESTARTING THE ENGINE.

1. Remove all load and allow engine to operate at low speed for 3-5 minutes; this allows further reduction of internal engine temperature.
2. Push Power/Emergency Stop switch in.

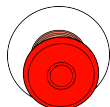

3. Turn key of Platform/Ground Select switch to the Off position.

Refer to Engine Manufacturer's manual for detailed information.



Air Shutoff Valve (ASOV) (If Equipped)

Air Shutoff Valve (ASOV) is an overspeed protection device mounted to the engine's air intake system. When the valve is actuated, it obstructs airflow intake and stops the engine. Weekly tests are recommended to ensure the valve remains in good working condition.

1. Start the engine, running at idle.
2. Open the red switch guard on ASOV test switch, then activate toggle to test mode.

NOTE: Test switch is located under hood to the left of the ground control panel (look for test decal).

3. At the ground control panel, select any function and activate until valve actuates at test RPM of 1500. Once valve actuates, engine will stop.
4. Turn ignition to OFF.
5. Visually inspect valve to ensure it appears in good condition.
6. Reset valve by rotating valve handle to the Open position.

NOTE: The handle cannot be turned unless the machine is off. Ensure the ignition is moved to the OFF position.



⚠ WARNING

DO NOT USE ASOV AS AN ALTERNATIVE TO SHUTTING DOWN MACHINE PROPERLY.

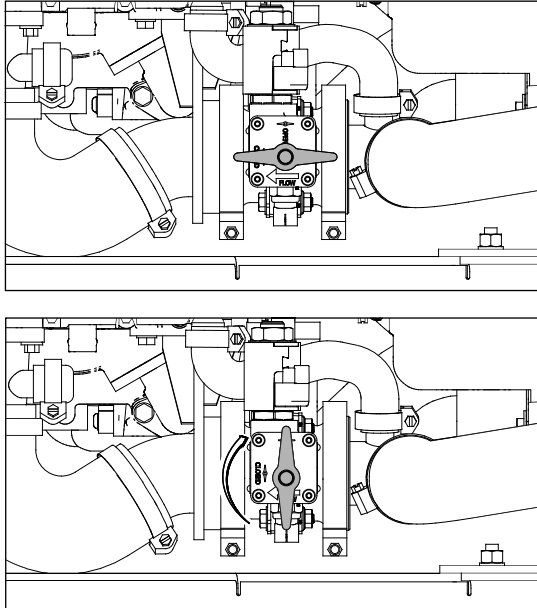

Figure 4-3. ASOV Reset (Closed to Open Position)

Fuel Reserve / Shut-Off System

NOTE: Reference the Service and Maintenance Manual along with a qualified JLG Mechanic to verify your machine setup.

The Fuel Shutoff System monitors the fuel in the tank and senses when the fuel level is getting low. The JLG Control System automatically shuts the engine down before the fuel tank is emptied unless the machine is set up for Engine Restart.

If fuel level reaches the Low Fuel range the $\frac{1}{4}$ tank indicator will flash once a second and there will be approximately 5 minutes of engine run time left. If the system is in this condition and automatically shuts down the engine, or the engine is manually shut down before the 5 minute run time is complete, the $\frac{1}{4}$ tank indicator will flash 10 times a second and the engine will react according to machine setup. Setup options are as follows:



- Engine One Restart - When the engine shuts down, the operator will be permitted to cycle power and restart the engine once with approximately 2 minutes of run time. After the 2 minute run time is complete or if the engine is shut down by the operator prior to the completion of the 2 minute run time, it cannot be restarted until fuel is added to the tank.
- Engine Restart - When the engine shuts down, the operator will be permitted to cycle power and restart the engine

SECTION 4 - MACHINE OPERATION

for approximately 2 minutes of run time. After the 2 minutes of run time is complete, the operator may cycle power and restart the engine for an additional 2 minutes of run time. The operator can repeat this process until there is no more fuel available.

NOTICE

CONTACT A QUALIFIED JLG MECHANIC IF THE MACHINE NEEDS RESTARTED AFTER NO MORE FUEL IS AVAILABLE.

- Engine Stop - The engine will shut down. No restarts will be permitted until fuel is added to the tank.

4.6 SELECTIVE CATALYTIC REDUCTION (SCR) - MACHINES USING DIESEL EXHAUST FLUID (DEF)

Selective Catalytic Reduction (SCR) is an emissions control used in diesel engines and requires operator interaction to ensure proper operation of the system.

The system injects liquid through a special catalyst into the exhaust stream of a diesel engine. The liquid is automotive-grade urea, otherwise known as Diesel Exhaust Fluid (DEF). The DEF sets off a chemical reaction that converts nitrogen oxides into nitrogen, water and carbon dioxide (CO₂), which is then expelled through the engine exhaust pipe.

For peak operation, the SCR system must be cleaned using one of two methods, Standstill Cleaning and Maintenance Standstill Cleaning. Standstill Cleaning is any cleaning requested by the engine outside of the regular maintenance window (for example, if the system detects crystallization in the DEF solution). Maintenance Standstill Cleaning is cleaning requested by the engine on the regular maintenance interval.

NOTE: *The system will reset the maintenance interval back to 0 hours after Standstill or Maintenance Standstill cleaning events are performed.*

Standstill Cleaning

The following conditions must be met to perform Standstill Cleaning.

- Machine must be stationary
- Boom in the stowed position
- No personnel in platform
- Engine must be idling
- Coolant temperature must be above 104° F (40° C)
- Diesel Exhaust Fluid (DEF) tank must not be frozen
- Machine in Ground Station mode

1. The Selective Catalytic Reduction Indicator will flash when standstill cleaning is required.



2. Move the machine to a suitable area free of flammables and personnel that could be exposed to hot exhaust.
3. Launch the cleaning process by pressing the SCR button on the Ground Console for 3 seconds. The Indicator Gauge will display the following screen.

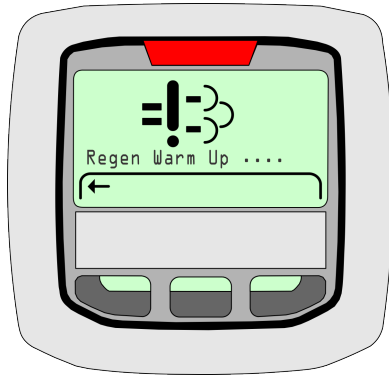

4. The Main Cleaning process will begin and last for approximately 30 to 60 minutes. The following screen will show that the process has begun and includes a status bar that indicates the progress of the cleaning process.

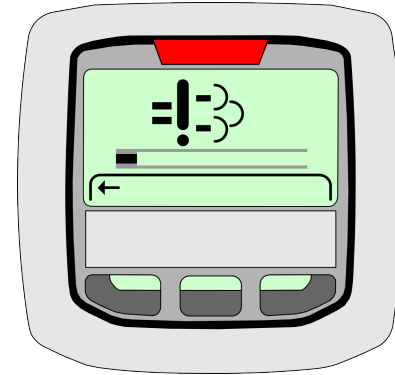

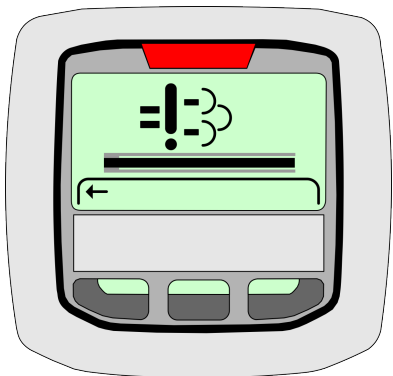

5. After the cleaning process is complete, the engine will run for approximately 5 minutes to allow the Engine and Exhaust After Treatment (EAT) to cool down. The Indicator Gauge will display the "Regen Complete" screen as shown and the HEST indicator will no longer be illuminated.

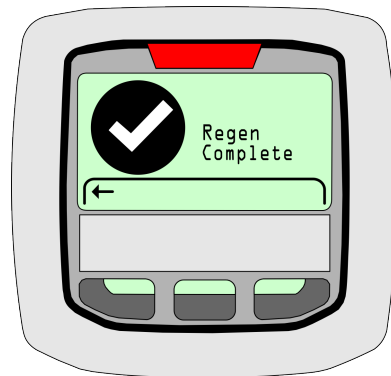

Maintenance Standstill Cleaning Initiation Methods

Maintenance Standstill Cleaning can be started by one of two methods, by using the Analyzer or SCR button on the Ground Console. All the same conditions as outlined under Standstill Cleaning must be met.

Canceling Maintenance Standstill

Maintenance Standstill Cleaning will be stopped immediately if:

- The Platform/Ground Select switch is switched from Ground to Platform mode
- Any function switch is enabled to perform a boom function
- The Engine is powered down

If Maintenance Standstill Cleaning is interrupted, it must be re-initiated and the Indicator Gauge will display the "Regen Failed" screen as shown.

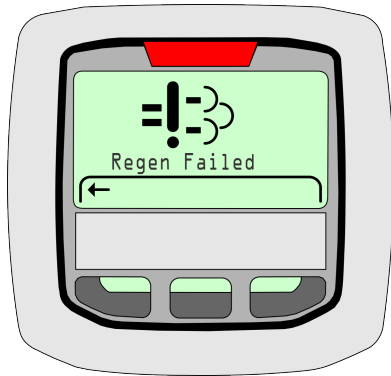

Unsuccessful Cleaning Event

If there is an unsuccessful cleaning event, The SCR icon will show on the display gauge. Possible causes of an Unsuccessful Cleaning Event are:

- Engine is not warmed up
- DEF tank is frozen
- Machine functions operated during cleaning event in progress
- Other engine faults are active

The Indicator Gauge will display the "Regen Failed" screen as shown. If the cleaning event has failed, it must be repeated.

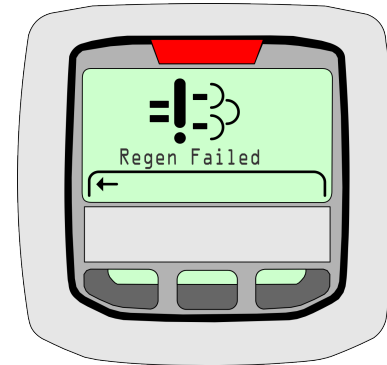

SECTION 4 - MACHINE OPERATION

Table 4-1. Maintenance Standstill Cleaning











Standstill Cleaning Levels		Machine Hours Since Last Cleaning	System Distress Light	SCR Cleaning Light	Derate	Comments
0	Normal Operation	0-500	--	--	None	Between 500 and 1000 hours, cleaning cycle can be initiated with JLG analyzer.
		500-1000				
1	Standstill Required	1000-1100	--	 0.5 Hz	None	Engine coolant temperature must be >40°C and DEF must be thawed before cleaning can be initiated.
2	Warning Level	1100-1125	 Continuous	 0.5 Hz	Machine placed in Creep and DTC active	
3	Shut Off Level	>1125	 Blinking	 3 Hz	Idle Lock. Boom Functions Locked Out and Trapped in Transport.	Contact Deutz Dealer.

Table 4-2. Cleaning When Crystallization is Detected During SCR

Crystallization Levels	Machine Hours after Crystallization	Cleaning Initiation Methods	System Distress Light	SCR Cleaning Light	Derate
Normal Operation	No Crystallization Detected	--	--	--	None
Crystallization Detected Standstill Required	0-5	SCR Switch or Analyzer	--	 0.5 Hz	None
Crystallization Detected Warning Level 1	5-600	SCR Switch or Analyzer	 Continuous	 0.5 Hz	Machine placed in Creep and DTC active
Crystallization Detected Shut Off Level	>600	Contact Deutz Dealer	 Blinking	 3 Hz	Idle Lock. Boom Functions Locked Out and Trapped in Transport.

SECTION 4 - MACHINE OPERATION

4.6 TRAVELING (DRIVING)

See Figure 4-5., Grade and Side Slopes - Sheet 2 of 2

NOTE: When the main boom is raised approximately 3 degrees above horizontal, the high drive function will automatically be in low drive.

WARNING

DO NOT DRIVE WITH BOOM ABOVE HORIZONTAL EXCEPT ON A SMOOTH, FIRM SURFACE WITHIN THE LIMITS OF THE MAXIMUM OPERATING SLOPE.

TO AVOID LOSS OF TRAVEL CONTROL OR TIP OVER, DO NOT DRIVE MACHINE ON GRADES EXCEEDING THOSE SPECIFIED IN THE OPERATING SPECIFICATIONS SECTION OF THIS MANUAL.

DO NOT DRIVE ON SIDESLOPES WHICH EXCEED 5 DEGREES.

USE EXTREME CAUTION WHEN DRIVING IN REVERSE AND AT ALL TIMES WHEN THE PLATFORM IS ELEVATED.

BEFORE DRIVING, LOCATE THE BLACK/WHITE ORIENTATION ARROWS ON BOTH THE CHASSIS AND THE PLATFORM CONTROLS. MOVE THE DRIVE CONTROLS IN A DIRECTION MATCHING THE DIRECTIONAL ARROWS FOR THE INTENDED DIRECTION OF TRAVEL.



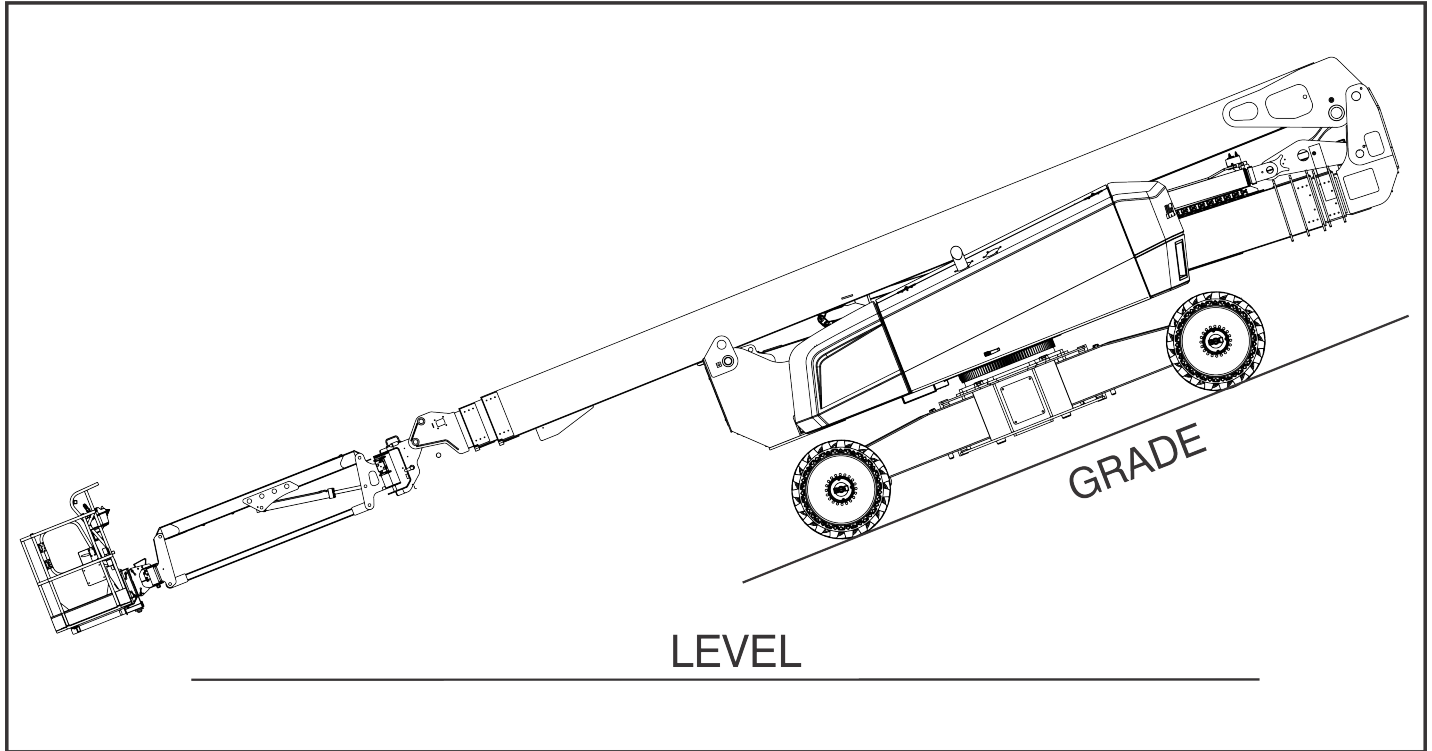

Figure 4-4. Grade and Side Slopes - Sheet 1 of 2

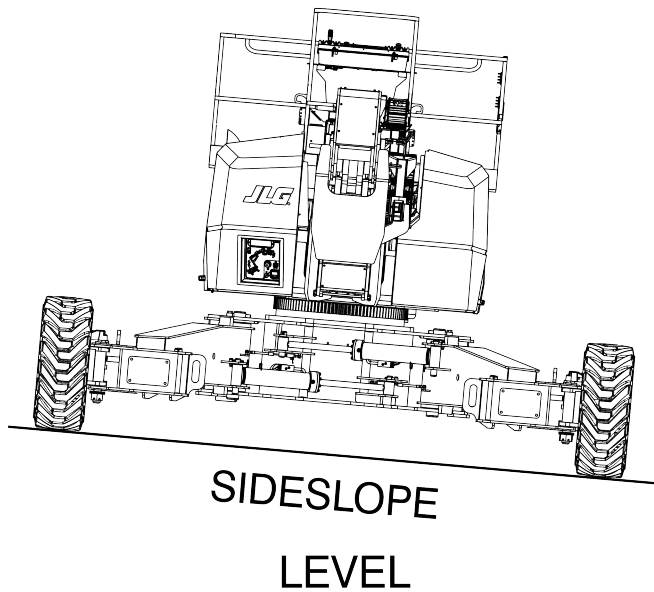
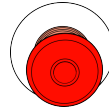

Figure 4-5. Grade and Side Slopes - Sheet 2 of 2

Traveling Forward and Reverse

1. At Platform Controls, pull out Emergency Stop switch, start engine, and activate footswitch.



2. Position Drive controller to Forward or Reverse as desired.

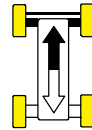

This machine is equipped with a Drive Orientation Indicator. The yellow light on the platform control console indicates that the boom is swung beyond the rear drive tires and the machine may Drive/Steer in the opposite direction from the movement of the controls. If the indicator is illuminated, operate the Drive function in the following manner:

1. Match the black and white direction arrows on both platform control console and the chassis to determine the direction the machine will travel.

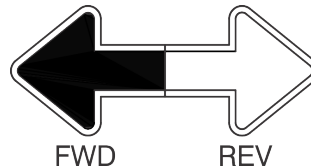

2. Push and release the Drive Orientation Override switch. Within 3 seconds, slowly move the Drive control toward the arrow matching the intended direction of machine travel. The indicator light will flash during the 3 second interval until the drive function is selected.



Traveling on a Grade

When traveling a grade, maximum braking and traction are obtained with the boom stowed, in position over the rear axle, and in line with the direction of travel. Drive the machine forward when climbing a grade, and in reverse when descending a grade. Do not exceed the machine's maximum rated gradeability.

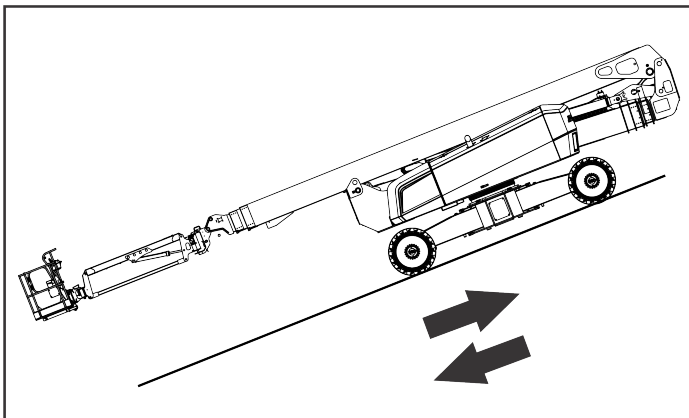

Figure 4-6. Traveling on a Grade

NOTICE

IF THE BOOM IS OVER THE FRONT (STEER) AXLE, DIRECTION OF STEER AND DRIVE MOVEMENT WILL BE OPPOSITE FROM THE MOVEMENT OF THE CONTROLS.

4.7 STEERING

Position thumb switch on Drive/Steer controller to Right for steering right, or to Left for steering left.



4.8 EXTENDING THE AXLES

NOTE: The boom must be in the transport position to extend or retract the axles. Transport position is defined as:

Tower boom angle $\leq 0^\circ$

Tower boom length $\leq 4"$ (100mm)

Main boom angle (With tower in transport position) $\leq 3^\circ$

Main boom length $\leq 4"$ (100mm)

The operator must be driving the machine (forward or reverse) in order to extend the axles.

Position the Axle Extend switch to extend the axles or to retract to retract the axles.

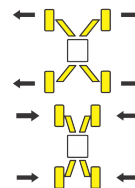

4.9 PLATFORM

Platform Level Adjustment

⚠ WARNING

ONLY USE THE PLATFORM LEVELING OVERRIDE FUNCTION FOR SLIGHT LEVELING OF THE PLATFORM. INCORRECT USE COULD CAUSE THE LOAD/OCCUPANTS TO SHIFT OR FALL. FAILURE TO DO SO COULD RESULT IN DEATH OR SERIOUS INJURY.

NOTE: *When the Boom Control Select Switch is in the Manual mode, Platform leveling only functions during Main Lift operation. When the Boom Control Select Switch is in the Automatic mode, Platform Leveling is active during all functions except during telescope operation. Also, when in the Manual mode, the Controlled Arc and Controlled Angle systems are not active.*

During normal operation of the machine, the platform will automatically maintain its position. To manually Level Up or Down - Position the Platform/Level control switch Up or Down and hold until the desired platform position is obtained.

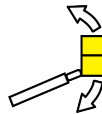

Platform Rotation

To rotate the platform to the left or right, use the Platform Rotate control switch to select the direction and hold until desired position is reached.

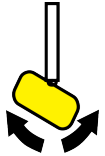

4.10 BOOM

⚠ WARNING

A RED TILT WARNING LIGHT IS LOCATED ON THE CONTROL CONSOLE WHICH LIGHTS WHEN THE CHASSIS IS ON AN EXCESSIVE SLOPE. DO NOT SWING OR RAISE BOOM ABOVE HORIZONTAL WHEN LIGHT IS LIT.



DO NOT DEPEND ON TILT ALARM AS A LEVEL INDICATOR FOR THE CHASSIS. TILT ALARM INDICATES CHASSIS IS ON AN EXCESSIVE SLOPE (5 DEGREE OR GREATER). CHASSIS MUST BE LEVEL BEFORE SWINGING, OR RAISING BOOM ABOVE HORIZONTAL OR DRIVING WITH THE BOOM ELEVATED.

TO AVOID TIP OVER IF RED TILT WARNING LIGHT LIGHTS WHEN BOOM IS RAISED ABOVE HORIZONTAL, LOWER PLATFORM TO GROUND LEVEL. THEN REPOSITION MACHINE SO THAT CHASSIS IS LEVEL BEFORE RAISING BOOM.

⚠ WARNING

TRAVELING WITH BOOM BELOW HORIZONTAL IS PERMITTED ON GRADES AND SIDE SLOPES SPECIFIED IN THE OPERATING SPECIFICATIONS SECTION OF THIS MANUAL.

⚠ WARNING

TO AVOID SERIOUS INJURY, DO NOT OPERATE MACHINERY IF ANY CONTROL LEVER OR TOGGLE SWITCH CONTROLLING PLATFORM MOVEMENT DOES NOT RETURN TO THE 'OFF' OR NEUTRAL POSITION WHEN RELEASED.

⚠ CAUTION

TO AVOID A COLLISION AND INJURY IF PLATFORM DOES NOT STOP WHEN A CONTROL SWITCH OR LEVER IS RELEASED, REMOVE FOOT FROM FOOTSWITCH OR USE EMERGENCY STOP SWITCH TO STOP THE MACHINE.

Swinging the Boom

To swing boom, use Swing control to select Right or Left direction.



NOTICE

WHEN SWINGING THE BOOM MAKE SURE THERE IS AMPLE ROOM FOR THE BOOM TO CLEAR SURROUNDING WALLS, PARTITIONS AND EQUIPMENT.

Raising and Lowering the Boom

NOTE: *The lift function is not operable above 6 degrees above horizontal if the axles are not fully extended.*

To raise or lower the Boom, use Boom Lift control to select Up or Down movement.



Telescoping the Boom

NOTE: *The telescope function is not operable beyond the transport position if the axles are not fully extended.*

To extend or retract the main boom, use the Telescope Control Switch to select In or Out movement.



Swinging the Jib

NOTE: For 1000 lb (454 kg for ANSI markets and 450 kg for CE and Australia markets) mode operation, the jib must be centered and the Jib Swing function is not operable. If the jib is out of the centered position when in this mode, the jib swing function will allow the operator to center the jib again.

To swing the jib, use the Jib Swing control to select Right or Left direction.

4.11 FUNCTION SPEED CONTROL

This control knob affects the speed of Telescope, Jib Swing, Jib Lift, Tower Boom Lift, and Platform Rotate functions.



NOTE: During platform rotation, a speed difference may not be noticeable to the operator.

Turning the knob all the way counterclockwise until it clicks puts the machine into Creep Mode. Creep Mode puts the functions listed above, as well as the Drive/Steer and Main Lift/Swing functions into the slowest speed setting.

4.12 MACHINE SAFETY SYSTEM OVERRIDE (MSSO) (IF EQUIPPED)

The Machine Safety System Override (MSSO) is used to override function controls for Emergency Platform Retrieval only. Refer to Section 6.5, MACHINE SAFETY SYSTEM OVERRIDE (MSSO) (If Equipped) for operating procedures.



4.13 SKYGUARD™ OPERATION

SkyGuard provides enhanced control panel protection. When the SkyGuard sensor is activated, functions in use at the time of actuation will reverse or cutout. The SkyGuard Function Table provides more details on these functions.

During activation, the horn will sound and, if equipped with a SkyGuard beacon, the beacon will illuminate until sensor and footswitch are disengaged.

If the SkyGuard sensor remains activated after function reversal or cutout, depress and hold the SkyGuard Override Switch to allow normal functions until the sensor is disengaged.

Consult the following illustrations to determine which type of SkyGuard the machine has and how it is activated. Regardless of type, SkyGuard function according to the SkyGuard Function Table does not change.

SECTION 4 - MACHINE OPERATION

SkyGuard

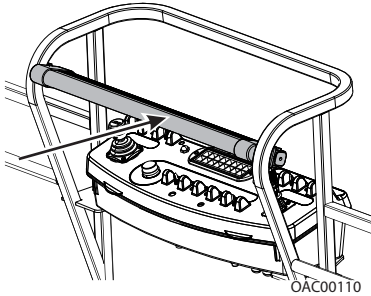

Approximately 50 lb (222 Nm) of force is applied to yellow bar.

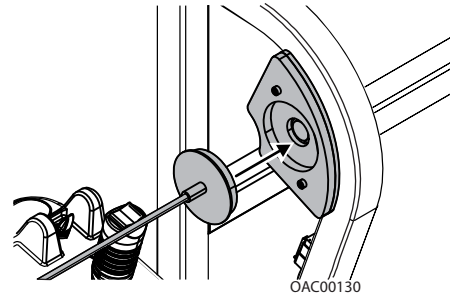

Reattach magnetic end of cable to bracket if it becomes disconnected.

SkyGuard - SkyLine

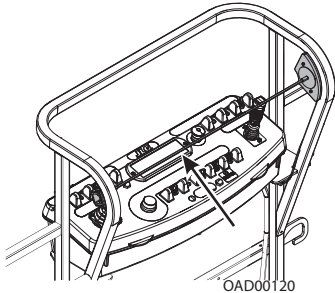

Cable is pressed, breaking the magnetic connection between the cable and right bracket.

SkyGuard - SkyEye

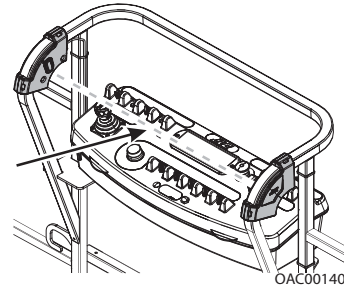

Operator passes through path of sensor beam.

SkyGuard Function Table

Drive Forward	Drive Reverse	Steer	Swing	Tower Lift Up	Tower Tele Out	Tower Lift Down	Tower Tele In	Boom Lift Up	Boom Lift Down	Boom Tele Out	Boom Tele In	Jib Lift	Jib Swing	Basket Level	Basket Rotate
R*/C**	R	C	R	C	C	C	C	R***/C****	R***/C****	R	C	C	C	C	C
R = Indicates Reversal is Activated															
C = Indicates Cutout is Activated															
* DOS (Drive Orientation System) Enabled															
** DOS Not Enabled, machine is driving straight without steering, and any other hydraulic function is active															
*** Operator is initiating command															
**** Control system is initiating command															

4.14 EMERGENCY TOWING

⚠ WARNING

RUNAWAY VEHICLE/MACHINE HAZARD. MACHINE HAS NO TOWING BRAKES. TOWING VEHICLE MUST BE ABLE TO CONTROL MACHINE AT ALL TIMES. ON-HIGHWAY TOWING NOT PERMITTED. FAILURE TO FOLLOW INSTRUCTIONS COULD CAUSE SERIOUS INJURY OR DEATH.

MAXIMUM TOWING SPEED 5 MPH (8 KM/H)

MAXIMUM TOWING GRADE 25%.

⚠ CAUTION

DO NOT TOW MACHINE WITH ENGINE OPERATING OR DRIVE HUBS ENGAGED.

1. Retract, lower and position boom in travel position; lock turntable.

2. Disconnect drive hubs by inverting disconnect cap.

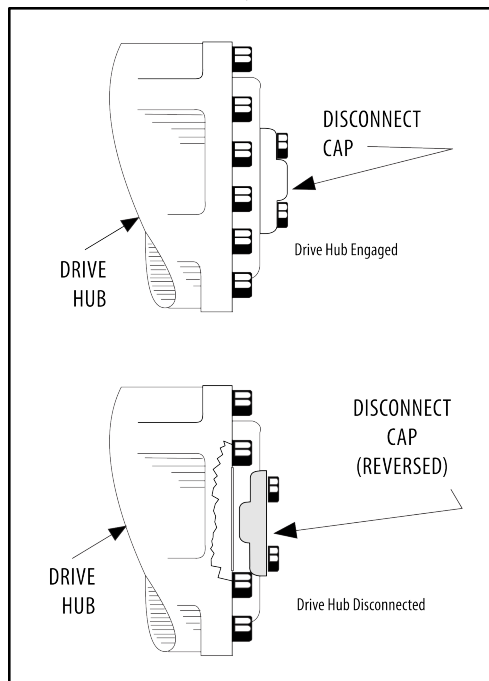

Figure 4-7. Drive Disconnect Hub

3. Reconnect the drive hubs by inverting the disconnect cap when towing is complete.

4.15 SHUT DOWN AND PARK

To shut down and park the machine, the procedures are as follows:

1. Drive machine to a reasonably well protected area.
2. Ensure boom is lowered over rear drive axle.
3. Push in the Emergency Stop at Platform Controls.
4. Push in the Emergency Stop at Ground Controls. Position Platform/Ground Select switch to the center Off position.
5. If necessary, cover Platform Controls to protect instruction placards, warning decals and operating controls from hostile environment.

4.16 LIFTING AND TIE DOWN

See Figure 4-8.

Lifting

1. Refer to the Serial Number Plate, refer to the Specifications section of this manual, or weigh the individual unit to find out the Gross Vehicle Weight.
2. Place the boom in the stowed position with the turntable locked.

3. Remove all loose items from the machine.
4. Attach lifting device and equipment only to the designated lifting points.
5. Properly adjust the rigging to prevent damage to the machine and so the machine remains level.

Tie Down

NOTICE

WHEN TRANSPORTING THE MACHINE, THE BOOM MUST BE FULLY LOWERED INTO THE BOOM REST.

1. Place the boom in the stowed position with the turntable locked.
2. Remove all loose items from the machine.
3. Secure the chassis and the platform using straps or chains of adequate strength and attached to the designated tie down points.

4.17 STOWING THE JIB FOR TRANSPORT

1. Place the boom in the stowed position with the turntable locked.
2. Remove all loose items from the machine.
3. Secure the chassis using straps or chains of adequate strength and attached to the designated tie down points.
4. Ensure the platform is lowered so the wear pad on the bottom rests on the surface of the transportation vehicle.
5. Secure through the tie downs on the boom using straps or chains of adequate strength.

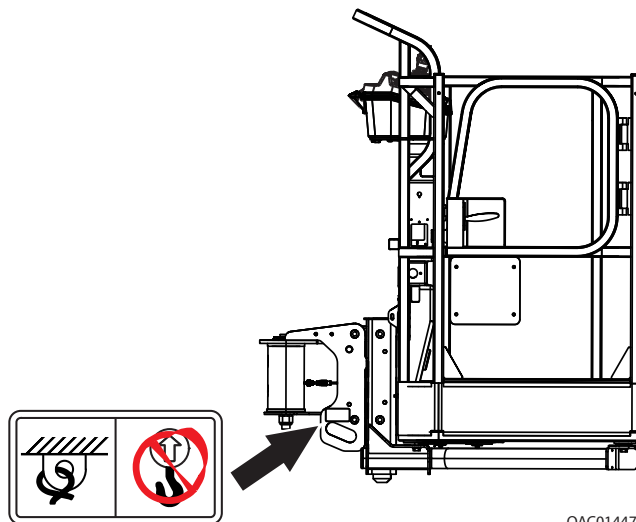

OAC014470

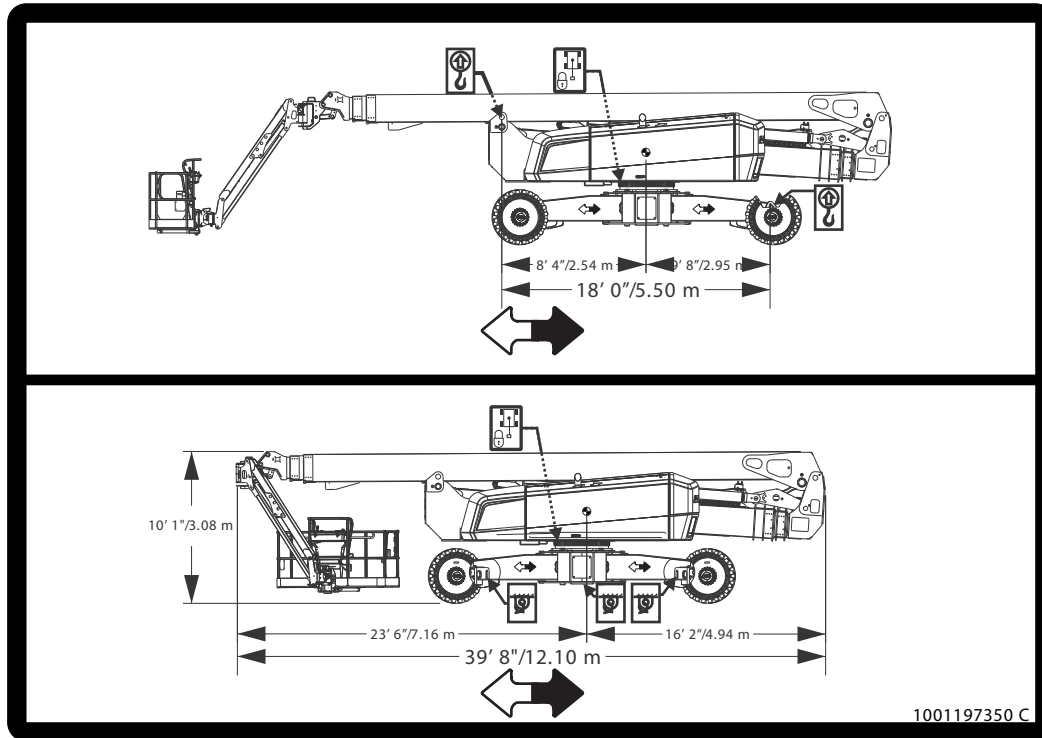

Figure 4-8. Lifting and Tie Down Chart

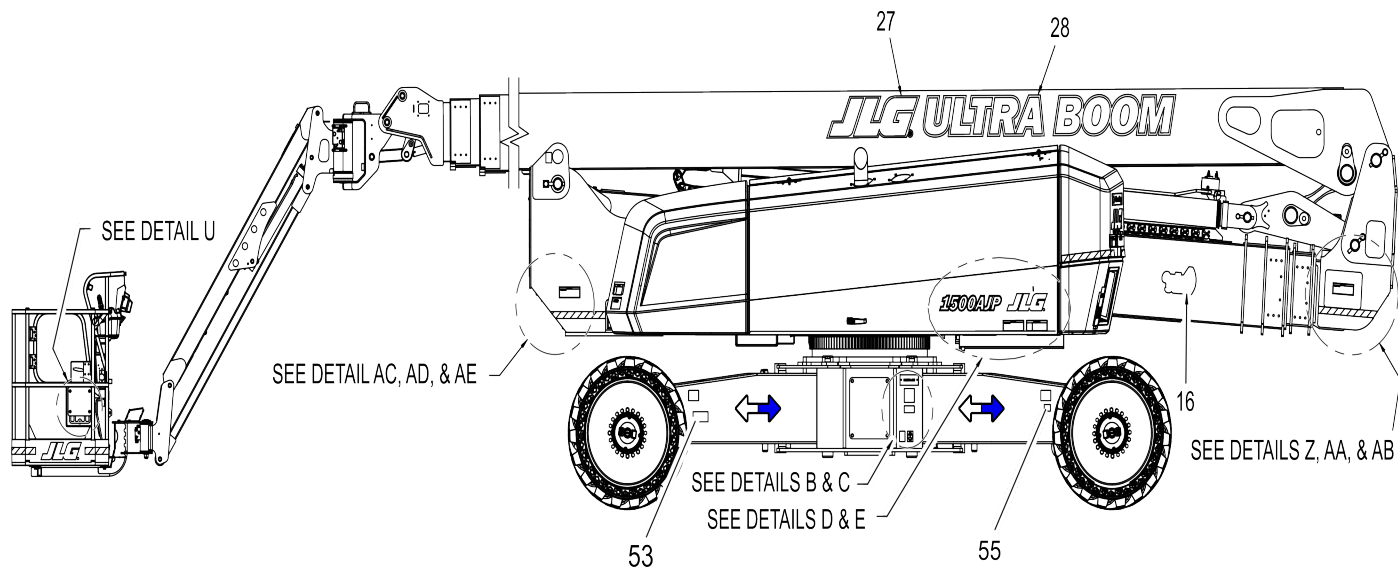

Figure 4-9. Decal Location Sheet 1 of 15

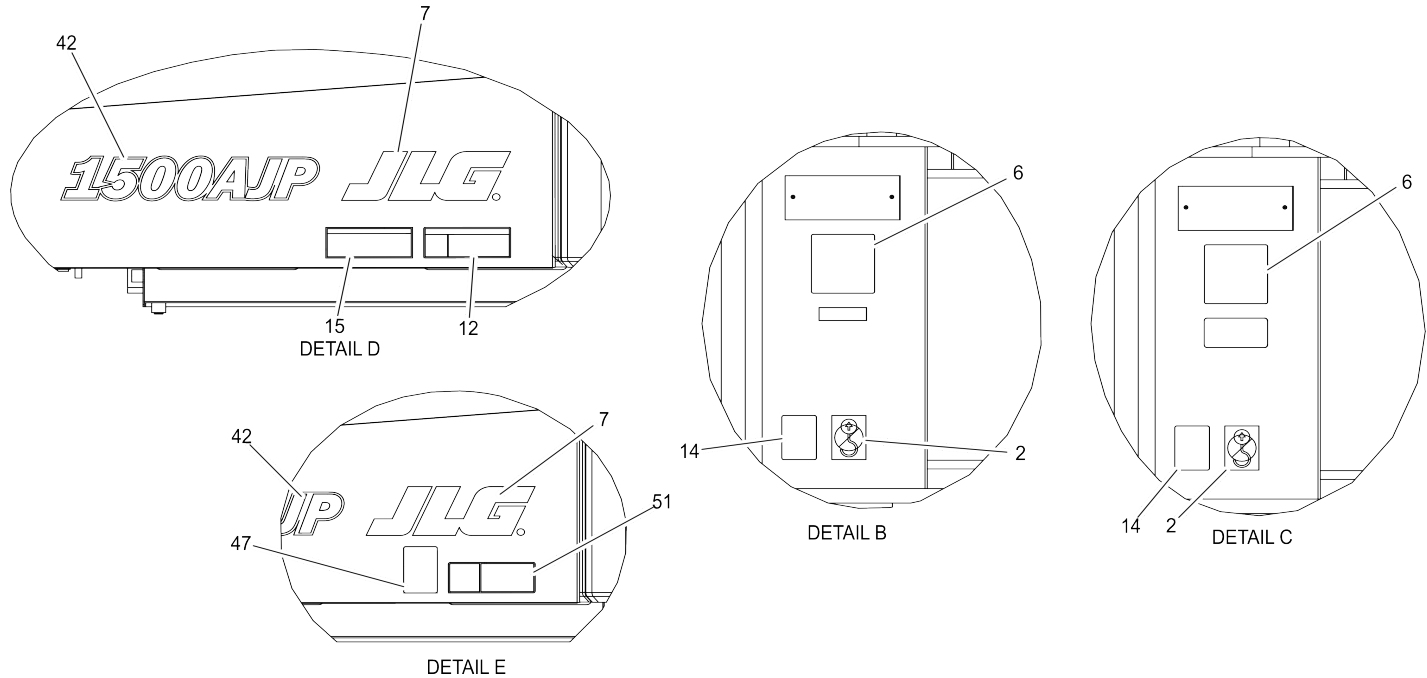

Figure 4-10. Decal Location Sheet 2 of 15

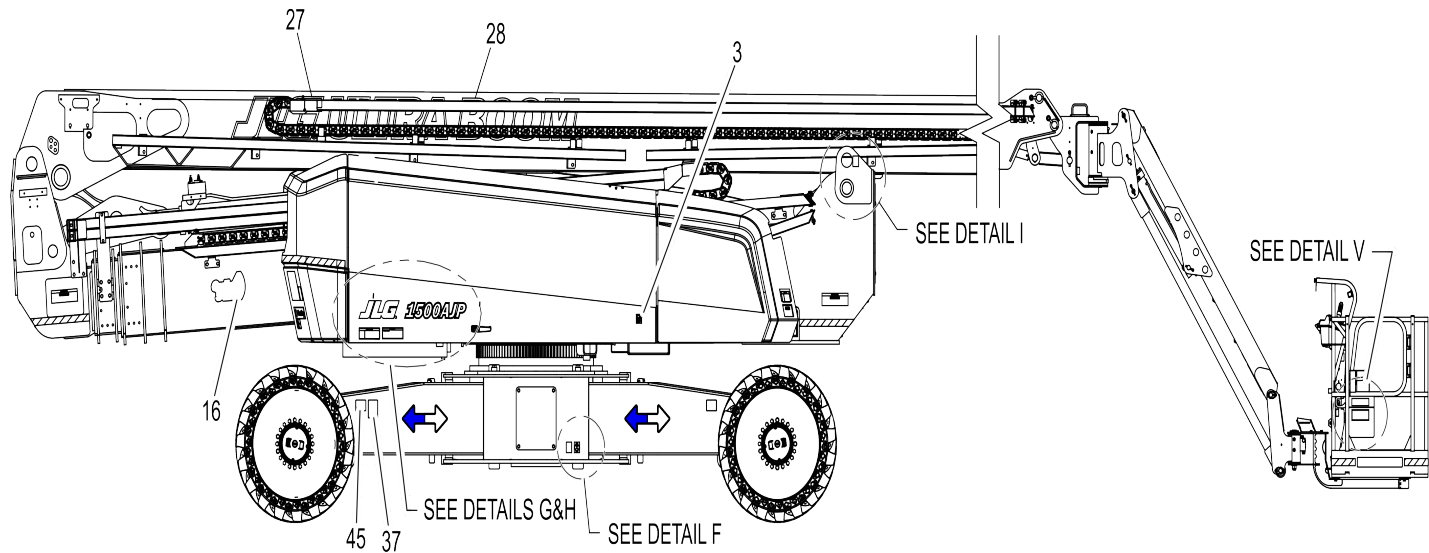

Figure 4-11. Decal Location Sheet 3 of 15

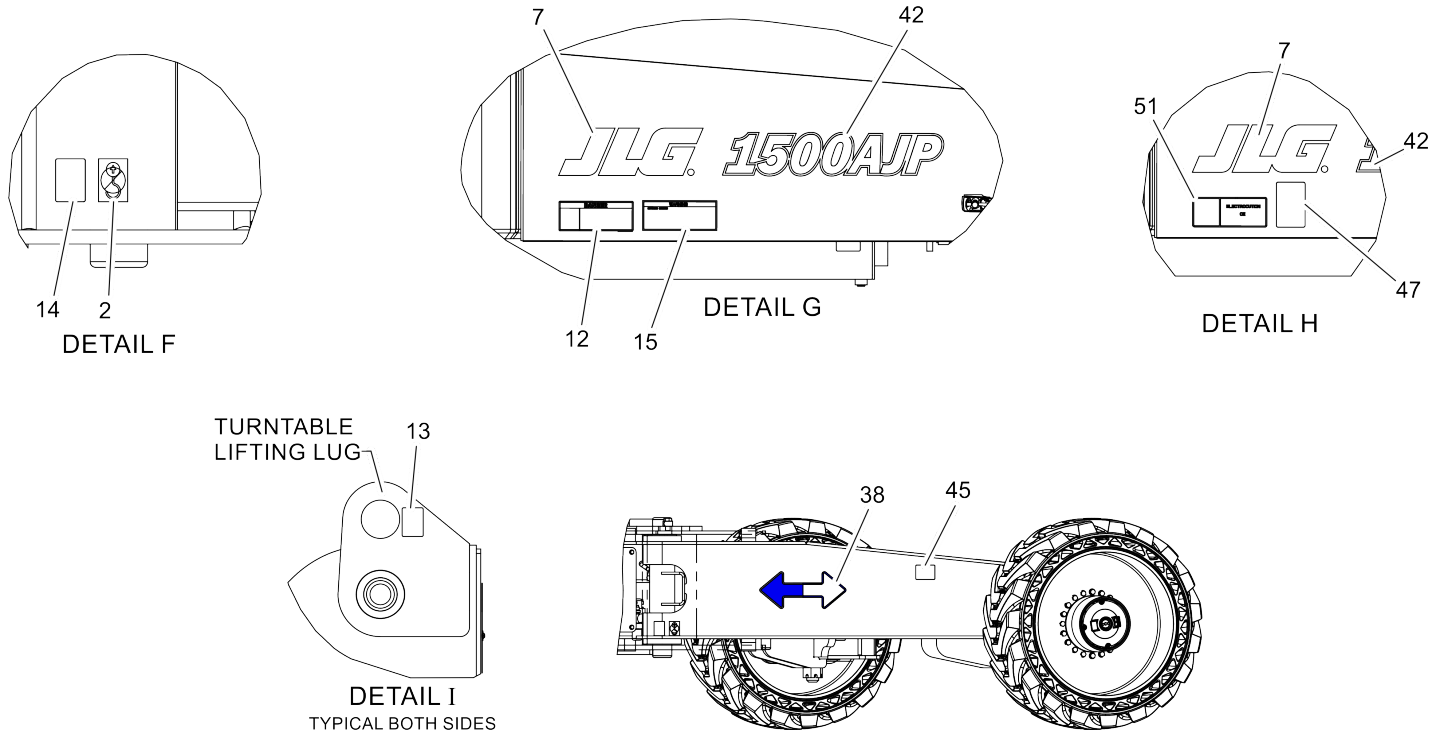

Figure 4-12. Decal Location Sheet 4 of 15

SECTION 4 - MACHINE OPERATION

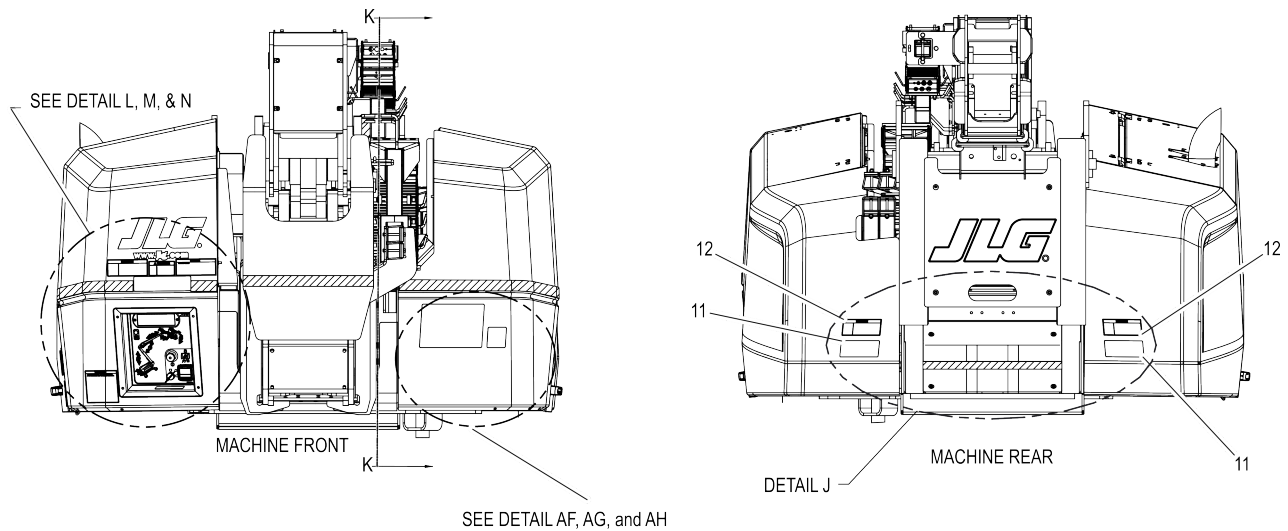
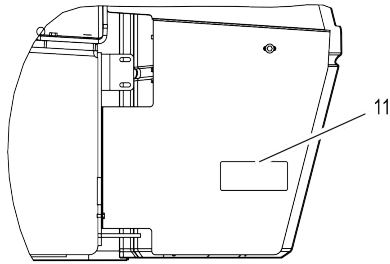
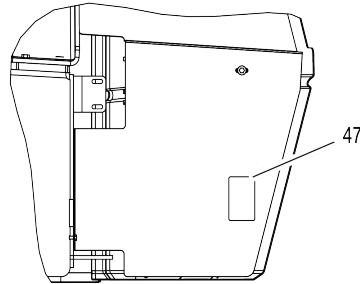

Figure 4-13. Decal Location Sheet 5 of 15



SECTION K-K
ANSI ONLY



SECTION K-K
CE & AUS ONLY

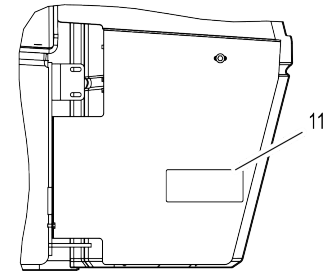

SECTION K-K
DUAL LANGUAGE ONLY

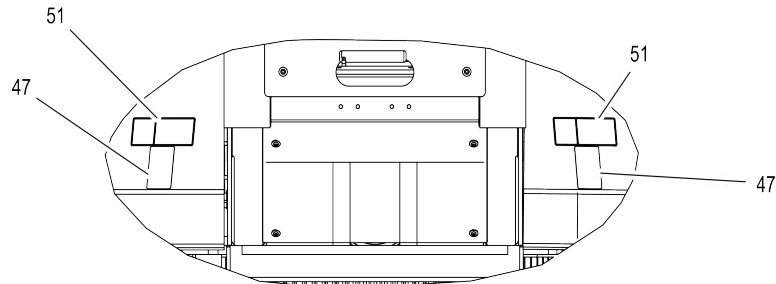

DETAIL J
CE & AUS ONLY

Figure 4-14. Decal Location Sheet 6 of 15

SECTION 4 - MACHINE OPERATION

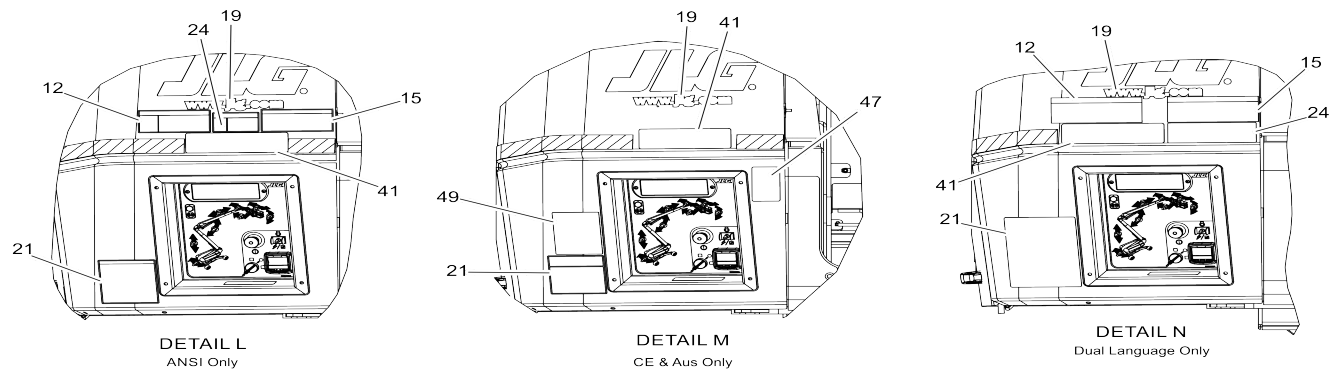

Figure 4-15. Decal Location Sheet 7 of 15

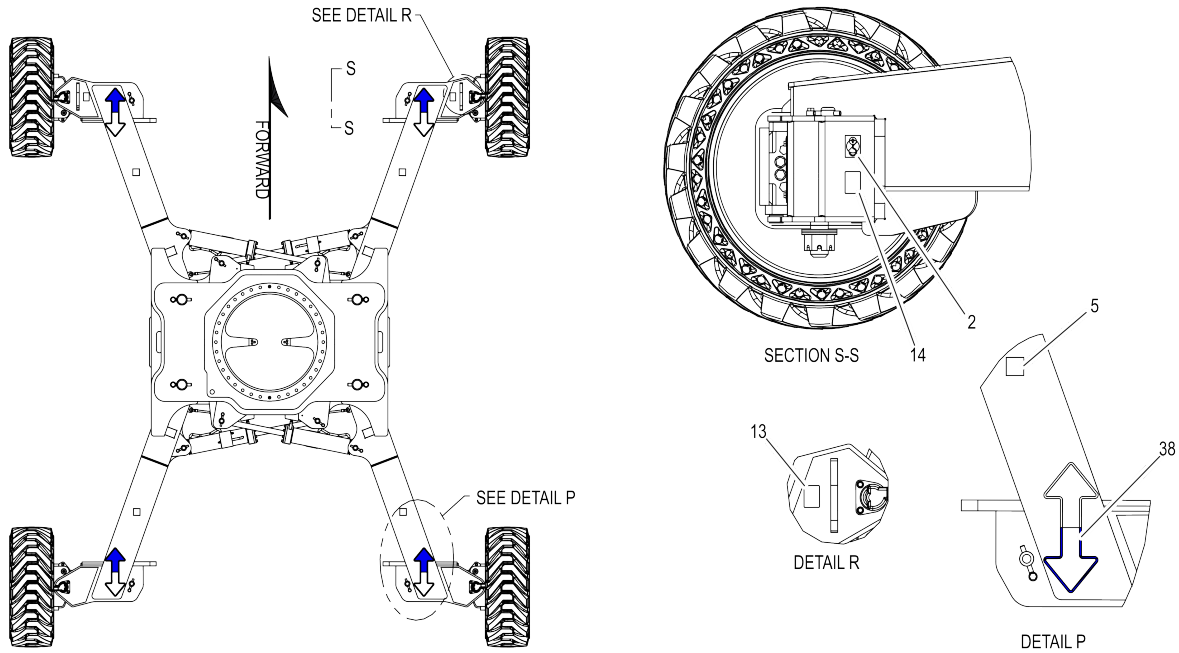

Figure 4-16. Decal Location Sheet 8 of 15

SECTION 4 - MACHINE OPERATION

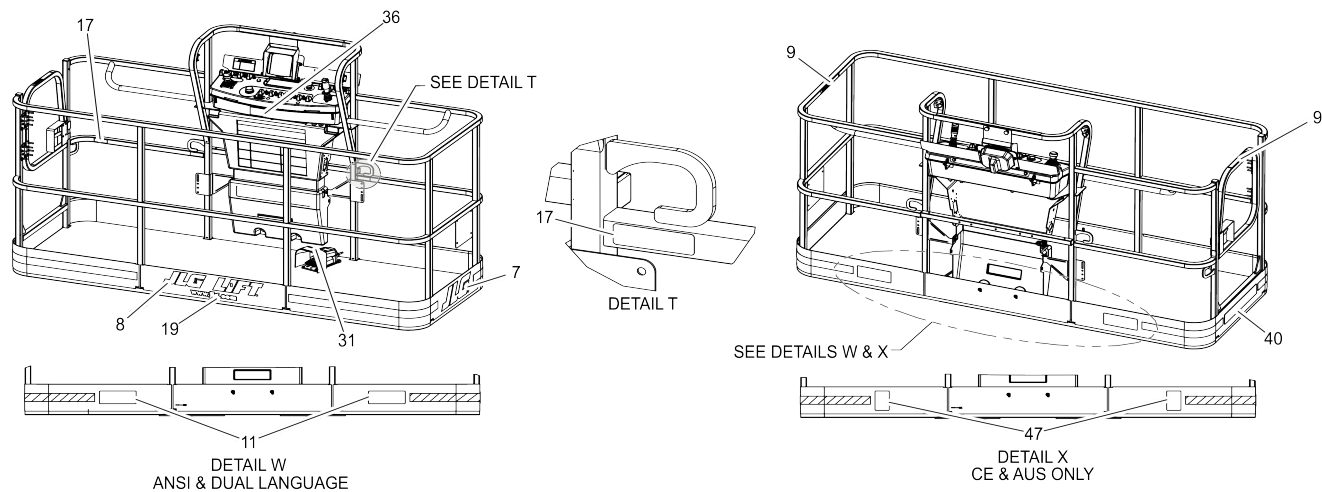

Figure 4-17. Decal Location Sheet 9 of 15

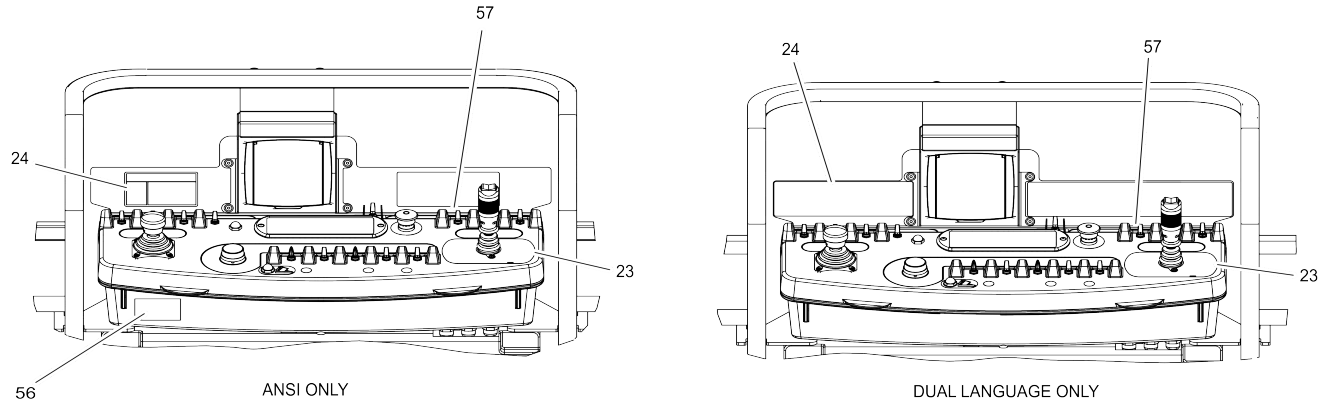
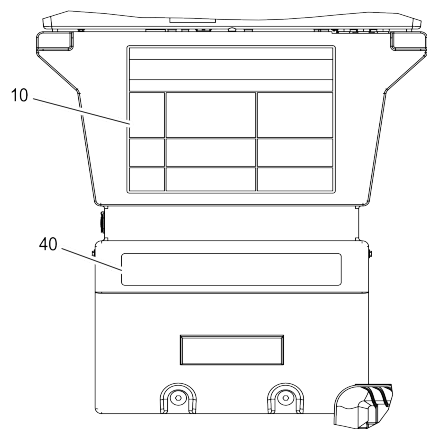
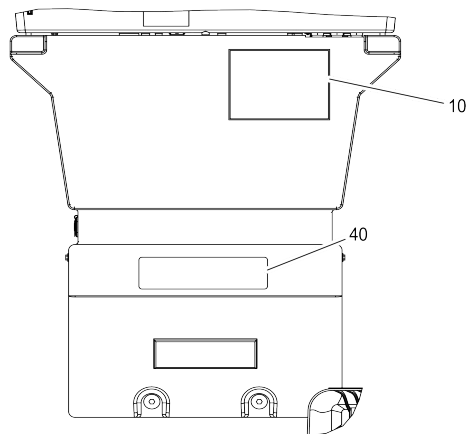

Figure 4-18. Decal Location Sheet 10 of 15



ANSI AND DUAL LANGUAGE



CE AND AUS

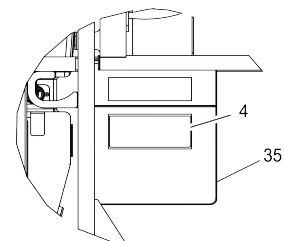

DETAIL V

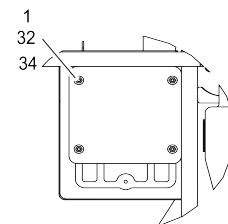

DETAIL U

Figure 4-19. Decal Location Sheet 11 of 15

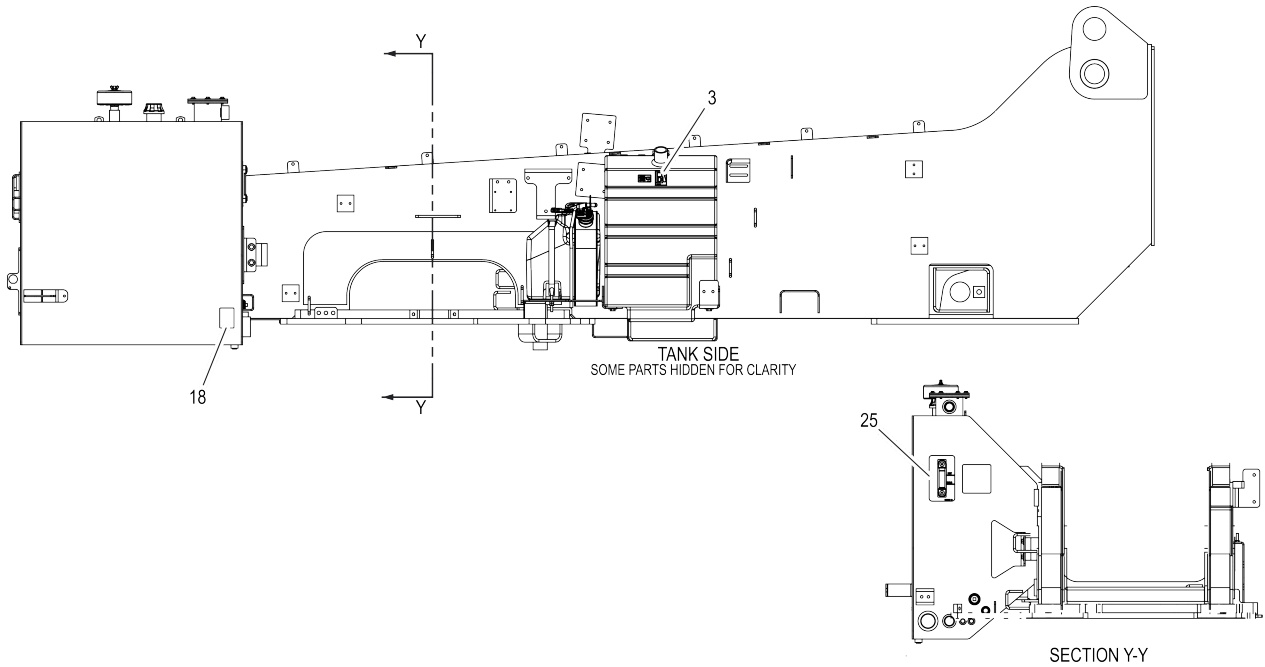

Figure 4-20. Decal Location Sheet 12 of 15

SECTION 4 - MACHINE OPERATION

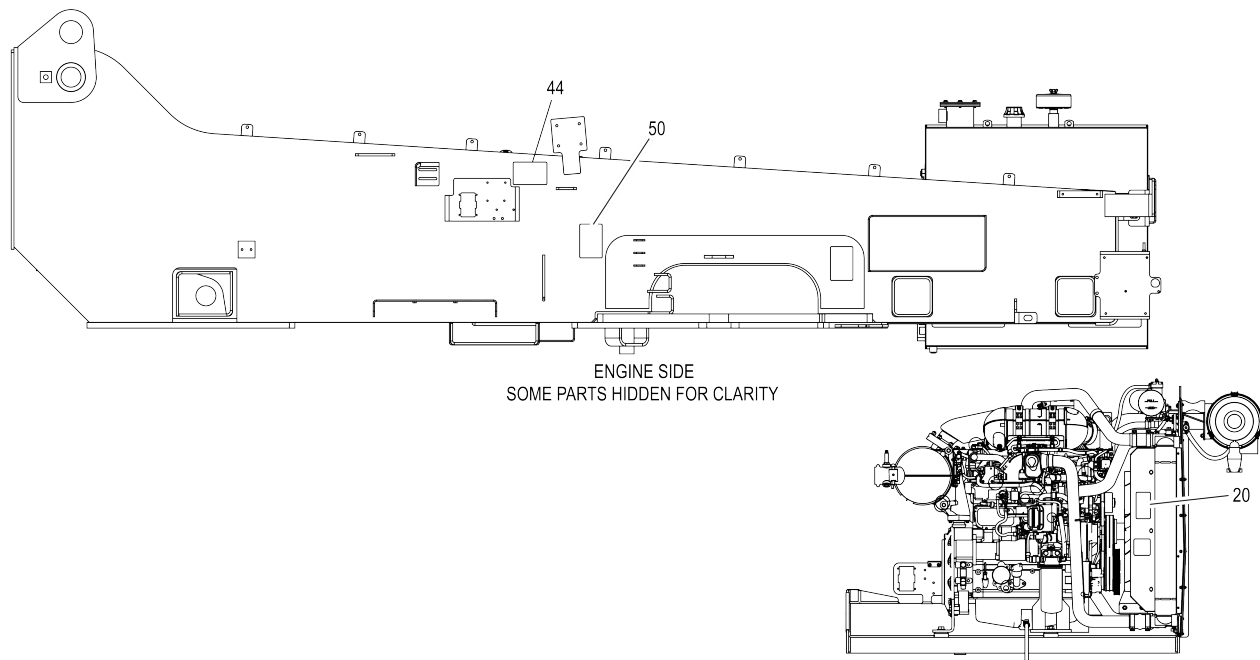

Figure 4-21. Decal Location Sheet 13 of 15

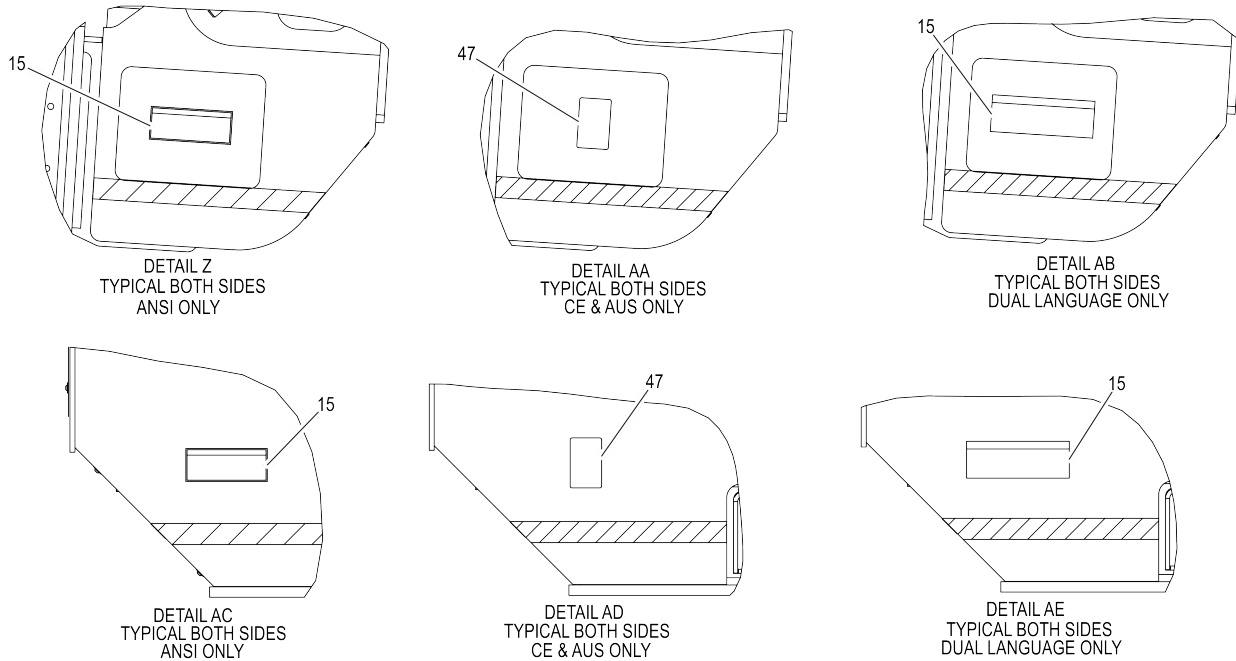
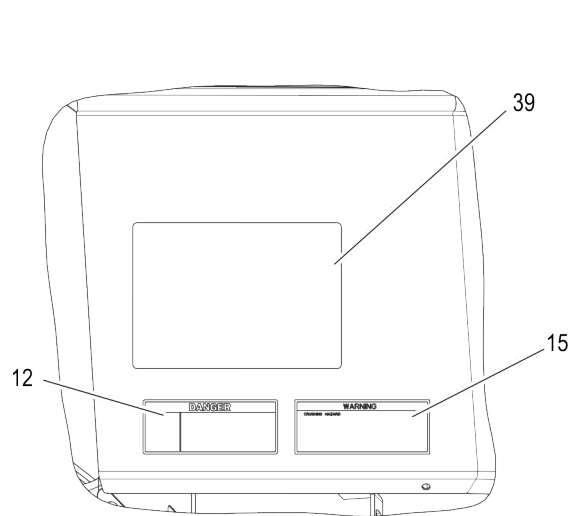
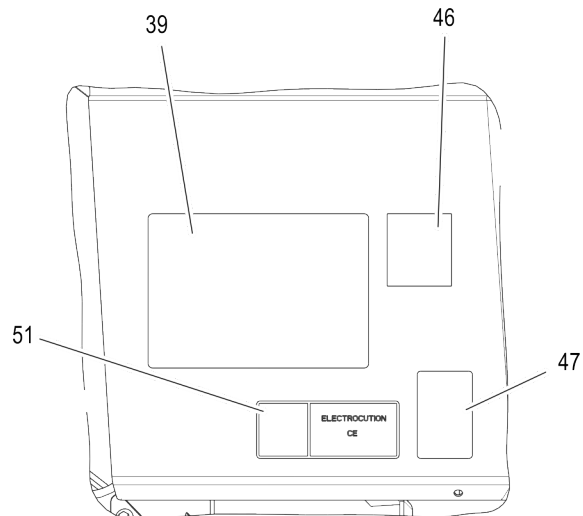

Figure 4-22. Decal Location Sheet 14 of 15

SECTION 4 - MACHINE OPERATION



DETAIL AF
ANSI & Dual Language



DETAIL AG
CE & AUS Only

Figure 4-23. Decal Location Sheet 15 of 15

Table 4-3. Decal Legend

Item #	ANSI 1001243091-C	French/English 1001243093-C	CE 1001246614-B	Korean 1001243094-C	Chinese 1001243095-C	Portuguese 1001243096-C	English/ Spanish 1001243097-C	Japan 1001243098-C	Australia 1001246615-B
1	0641406	0641406	0641406	0641406	0641406	0641406	0641406	0641406	0641406
2	1701499	1701499	1701499	1701499	1701499	1701499	1701499	1701499	1701499
3	1701505	1701505	1701505	1701505	1701505	1701505	1701505	1701505	1701505
4	1701509	1701509	1701509	1701509	1701509	1701509	1701509	1701509	1701509
5	1701691	1701691	1701691	1701691	1701691	1701691	1701691	1701691	1701691
6	1702631	1702631	1702631	1702631	1702631	1702631	1702631	1702631	1702631
7	1702773	1702773	1702773	1702773	1702773	1702773	1702773	1702773	1702773
8	1702774	1702774	--	1702774	1702774	1702774	1702774	1702774	1702774
9	1702868	1704000	--	1705969	1001116846	1705967	1704001	--	--
10	1001231315	1001231316	1705921	1001231317	1001231321	1001231319	1001231318	1001231320	1705921
11	1703804	1703948	--	1703951	1703949	1705898	1703947	1703950	--
12	1703805	1703936	--	1703939	1001116851	1705897	1703935	1703938	--
13	1703811	1703811	1703811	1703811	1703811	1703811	1703811	1703811	1703811
14	1703814	1703814	1703814	1703814	1703814	1703814	1703814	1703814	1703814
15	1703953	1703942	--	1703945	1703943	1705903	1703941	1703944	--
16	1703959	1703959	1703959	1703959	1703959	1703959	1703959	1703959	1703959

SECTION 4 - MACHINE OPERATION

Table 4-3. Decal Legend

Item #	ANSI 1001243091-C	French/English 1001243093-C	CE 1001246614-B	Korean 1001243094-C	Chinese 1001243095-C	Portuguese 1001243096-C	English/ Spanish 1001243097-C	Japan 1001243098-C	Australia 1001246615-B
17	1704277	1704277	1704277	1704277	1704277	1704277	1704277	1704277	1704277
18	1704412	1704412	1704412	1704412	1704412	1704412	1704412	1704412	1704412
20	1704972	1706064	1706098	1706061	1706060	1706059	1706063	1704972	1706098
21	1705336	1705347	1705822	1705345	1001116849	1705896	1705917	1705344	1705822
23	1705351	1705429	--	1705427	1705430	1705905	1405910	1705426	--
24	1705492	1705505	--	1705503	1001117035	1705906	1705915	1705493	--
25	1705511	1705511	1705511	1705511	1705511	1705511	1705511	1705511	1705511
27	1705864	1705864	1705864	1705864	1705864	1705864	1705864	1705864	1705864
28	1705865	1705865	--	1705865	1705865	1705865	1705865	1705865	1705865
31	3252347	1703984	1705828	1703981	1703982	1705902	1703983	1703980	1705828
32	3311405	3311405	3311405	3311405	3311405	3311405	3311405	3311405	3311405
33	3820001	3820001	3820001	3820001	3820001	3820001	3820001	3820001	3820001
34	4751400	4751400	4751400	4751400	4751400	4751400	4751400	4751400	4751400
35	91403230	91403230	91403230	91403230	91403230	91403230	91403230	91403230	91403230
37	1001131269	1001131269	--	--	--	--	--	--	--
38	1001160445	1001160445	1001160445	1001160445	1001160445	1001160445	1001160445	1001160445	1001160445
39	1001197350	1001197350	1001197350	1001197350	1001197350	1001197350	1001197350	1001197350	1001197350
40	1001254474	1001254476	1001200118	1001254478	1001254480	1001254482	1001254484	1001254486	1001200118

Table 4-3. Decal Legend

Item #	ANSI 1001243091-C	French/English 1001243093-C	CE 1001246614-B	Korean 1001243094-C	Chinese 1001243095-C	Portuguese 1001243096-C	English/ Spanish 1001243097-C	Japan 1001243098-C	Australia 1001246615-B
41	1001254475	1001254477	1001200117	1001254479	1001254481	1001254483	1001254485	1001254487	1001200117
42	1001200707	1001200707	1001200707	1001200707	1001200707	1001200707	1001200707	1001200707	1001200707
44	1001234789	1001234789	1001234789	1001234789	1001234789	1001234789	1001234789	1001234789	1001234789
45	1001209896	1001209896	1001209896	1001209896	1001209896	1001209896	1001209896	1001209896	1001209896
46	--	--	1705515	--	--	--	--	--	1705515
47	--	--	1701518	--	--	--	--	--	1701518
48	--	--	1001189882	--	--	--	--	--	--
49	--	--	--	--	--	--	--	--	1001112551
50	1001211904	1001211904	1001211904	1001211904	1001211904	1001211904	1001211904	1001211904	1001211904
51	--	--	1705961	--	--	--	--	--	1705961
52	1001224045	1001224045	1001224045	1001224045	1001224045	1001224045	1001224045	1001224045	1001224045
53	1001223055	1001223971	--	1001224048	1001224050	1001224052	1001224049	1001224053	--
55	1001223453	1001223453	--	--	--	--	--	--	1001229782
56	1001231801	--	--	--	--	--	--	--	--
57	1001195947	1001184619	1001184619	1001195947	1001195947	1001195947	1001195947	1001195947	1001184619

SECTION 5. LCD DISPLAY PANEL

5.1 DESCRIPTION

This machine utilizes an LCD display panel to assist the operator by supplying additional information during the operation of the machine. It is NOT a substitute for the Operation and Safety Manual, nor is it a replacement for thorough operational knowledge of the machine.

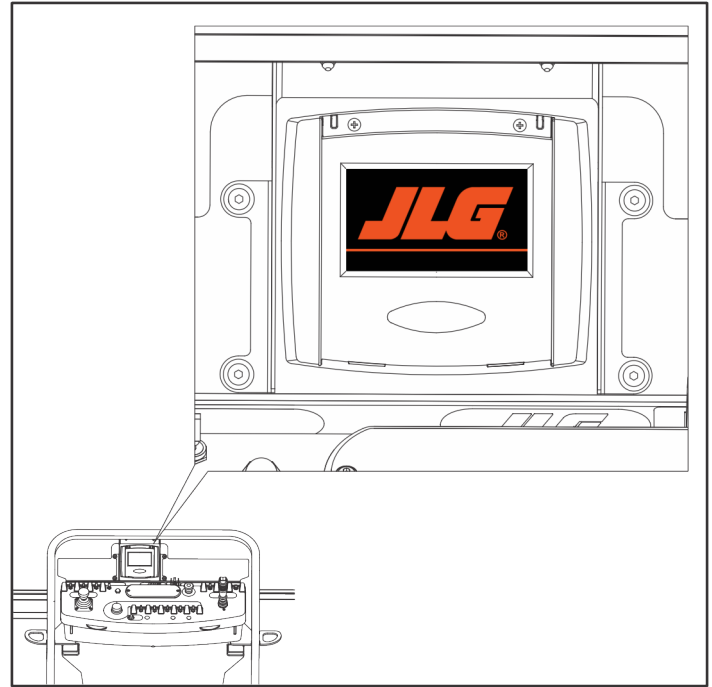

Figure 5-1. LCD Panel

5.2 BOOT UP SPLASH SCREEN

When the machine is first powered on, the JLG boot up splash screen appears followed by three reminder screens. There is a reminder for the operator to wear a full body harness with a lanyard attached to an authorized lanyard anchorage point, a reminder for the operator to read and understand the Operation and Safety Manual, and a reminder for the operator to select the desired capacity range of the machine. Each reminder screen will show for 3 seconds.



Figure 5-2. Boot Up Splash Screen

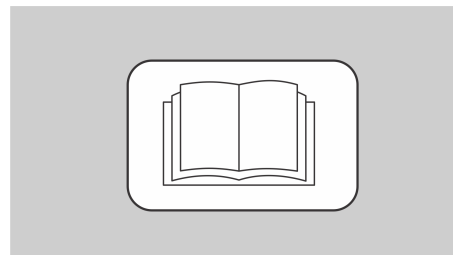

Figure 5-3. Manual Screen

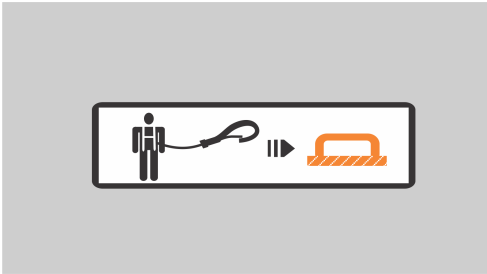

Figure 5-4. Lanyard Screen

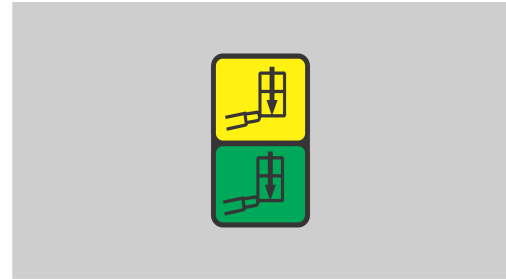

Figure 5-5. Select Capacity Zone Screen

5.3 MACHINE OPERATING SCREEN

After the reminder screens, the Machine Operating Screen will appear. The Machine Operating Screen consists of different

images and trays. Each tray provides different machine information.

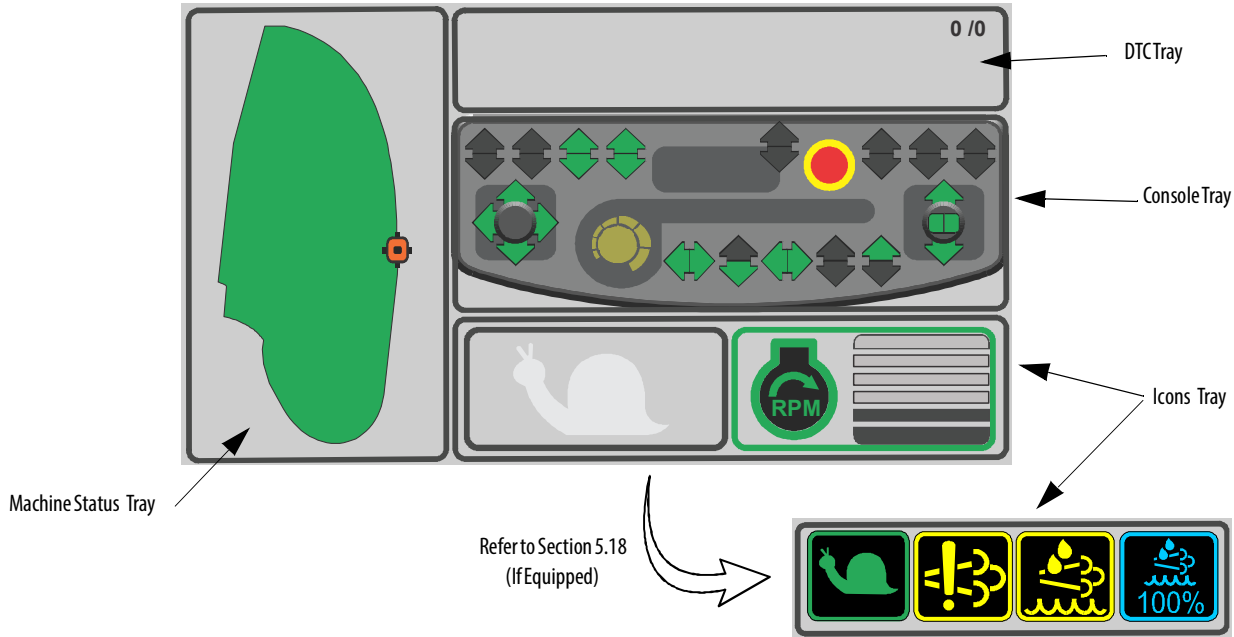

Figure 5-6. Machine Operating Screen

Diagnostic Trouble Code (DTC) Tray

This tray shows the total number of DTC's and the DTC Text. If there are multiple DTC's, the operator can scroll through the DTC List to the end. When the tray is empty, this means there are no active DTC's.

Console Tray

This tray represents the platform console information.

When the machine is in operation, and the footswitch is pressed, the console will show available functions with a green arrow and unavailable functions with a gray arrow.

NOTE: *The green and gray console arrows shown in the examples in this section may be different depending upon machine setup and specific operating conditions.*

Icons Tray

The Icons Tray shows engine RPM plus Creep and Super Creep modes.

The RPM level is represented in bars.

Machine Status Tray

The Machine Status Tray is used to display different images based on the machine status. These include:

- Key Switch Ground Mode
- CAN Bus Lost
- Take Foot Out
- Put Foot In
- BCS Lamp On
- Wire Rope Service
- System/Platform Level DTCs
- Platform Overload DTCs
- Weight Mode Error
- Chassis Status
- In Transport and Out of Transport
- Axles Extended, Retracted, Transient
- Machine Tilted
- Envelope Status
- Unknown Machine Model

5.4 KEYSWITCH IN GROUND MODE:

If the keyswitch is set to ground mode, the display shows the Key Switch in Ground Mode Image.

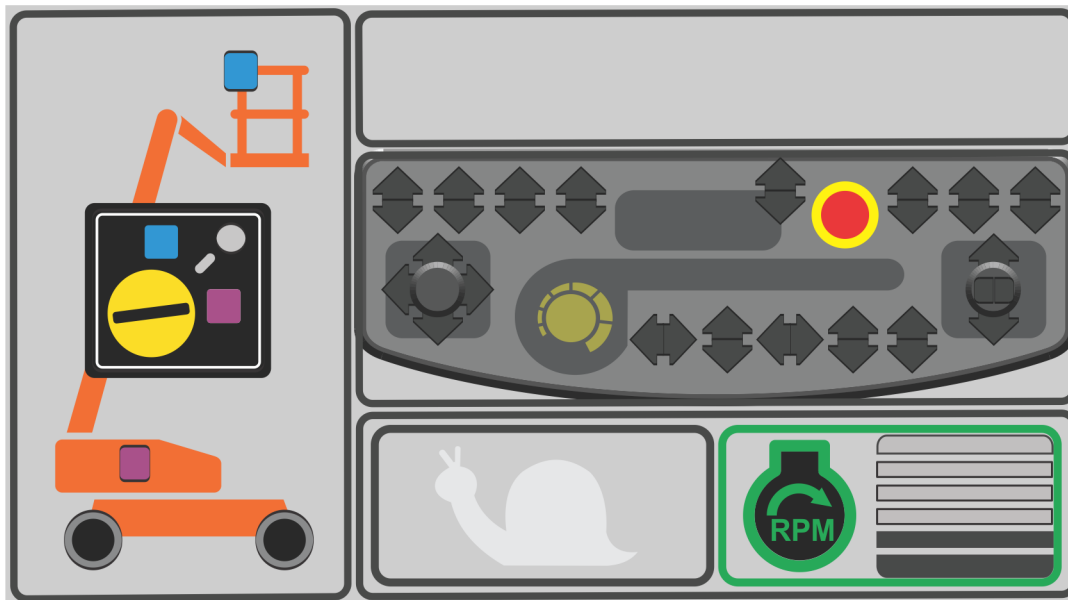

Figure 5-7. Keyswitch In Ground Mode Screen

5.5 FUNCTION SPEED

If there is no function speed restriction, a gray snail is shown. If the machine is in Creep Mode, a green snail icon is shown. If the machine is in Super Creep Mode, the green snail icon will flash.

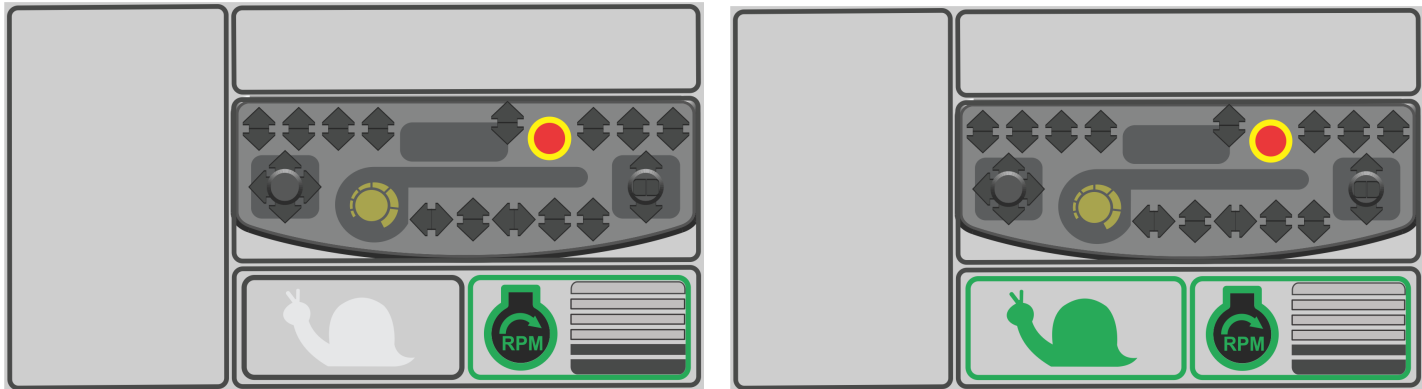

Figure 5-8. Function Speed Icons

5.6 CAN BUS LOST

When the control system senses a communication loss with any of the control modules (BLAM, Chassis, UGM, or Jib Control Module), the display will show a CAN Communication lost until the communications are reset.

NOTE: There is no way to get the active DTCs so, the previously active DTCs will be scrolling along with the CAN Bus Communication lost DTC. This DTC needs to be cleared in order for the communications to reset.

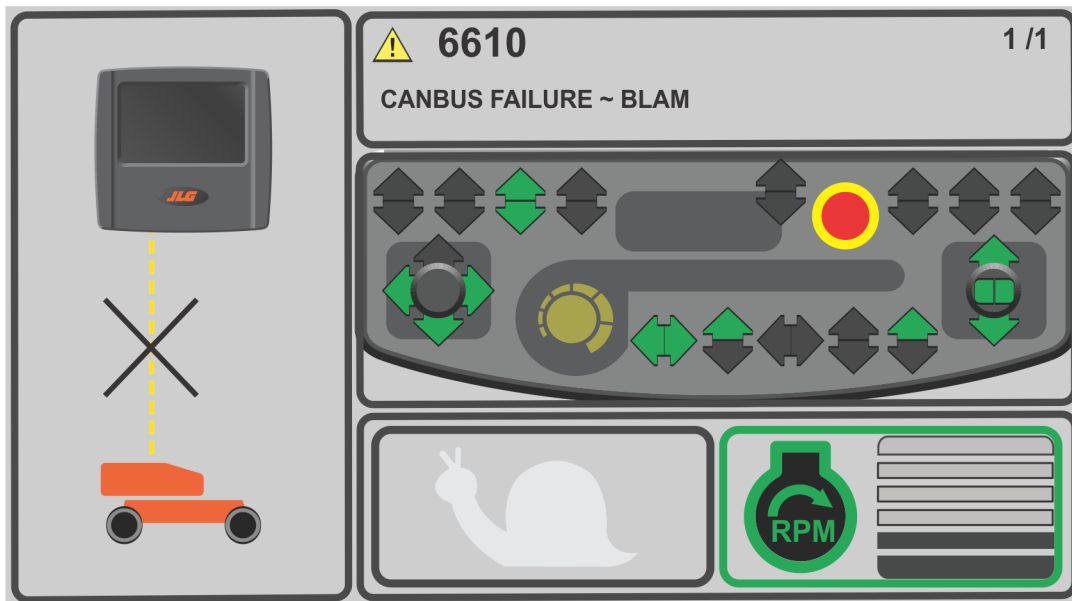

Figure 5-9. CAN Bus Lost Screen

5.7 TAKE FOOT OUT

When the footswitch is pressed and the control system senses a Take Foot Out DTC, the displays shows the Take Foot Out image in the machine status tray.

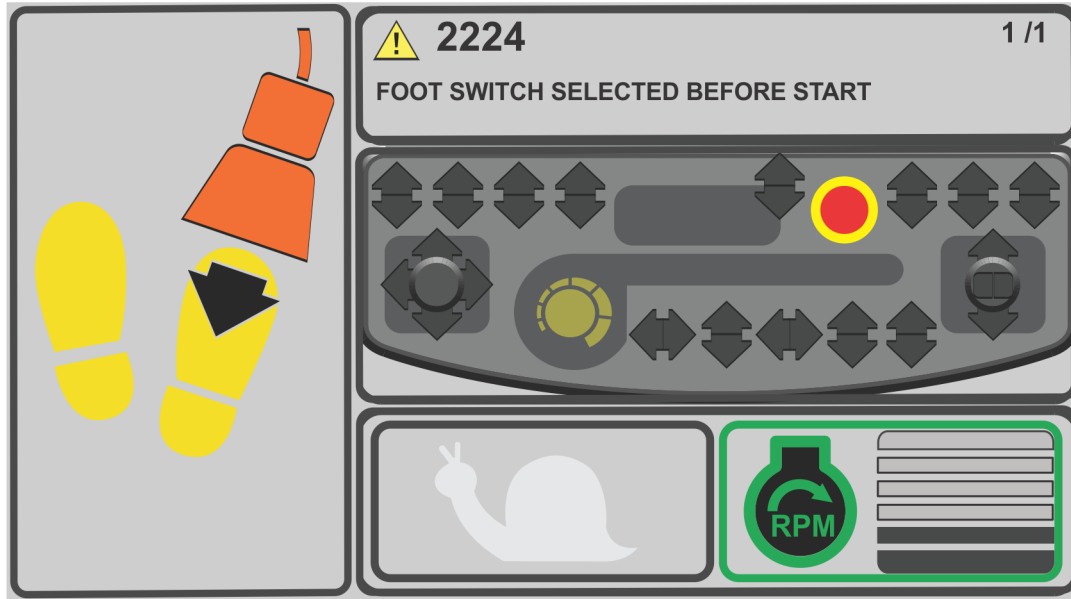

Figure 5-10. Take Foot Out Screen

5.8 PUT FOOT IN

When the operator operates the machine without putting his foot on switch, Put Foot In DTC becomes active after timeout.

When put foot in DTC is active, the display shows Put Foot In image in the machine status tray.

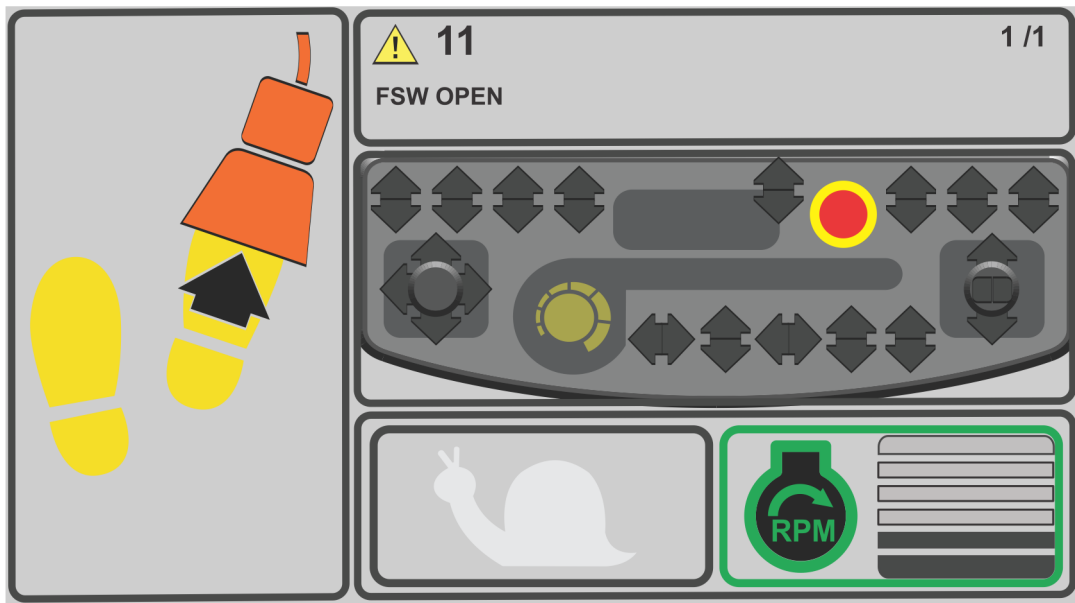

Figure 5-11. Put Foot In Screen

5.9 BOOM CONTROL SYSTEM (BCS) LAMP ON

When the boom control system senses the platform is outside the operating area, the BCS Lamp will be ON. When the BCS Lamp is ON, the display shows a red octagon image in the machine status tray indicating a potentially hazardous situation.

- The DTCs that triggered this BCS Lamp will be scrolled in the DTC tray.

NOTE: *The available controls will be different among the different DTCs. The image below is ONLY for envelope violation.*

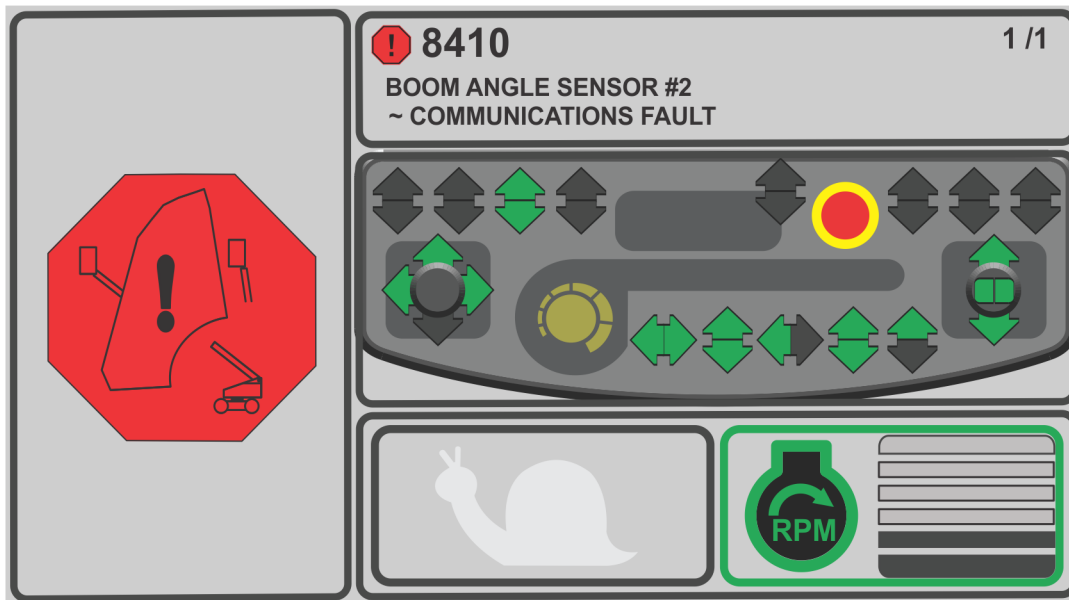

Figure 5-12. BCS Lamp Screen

5.10 WIRE ROPE SERVICE

When the control system senses a loose or broken wire rope, the Wire Rope Service lamp on the platform panel is lit. When the

lamp is lit, the display shows a red octagon wire rope service indicator in the machine status tray.

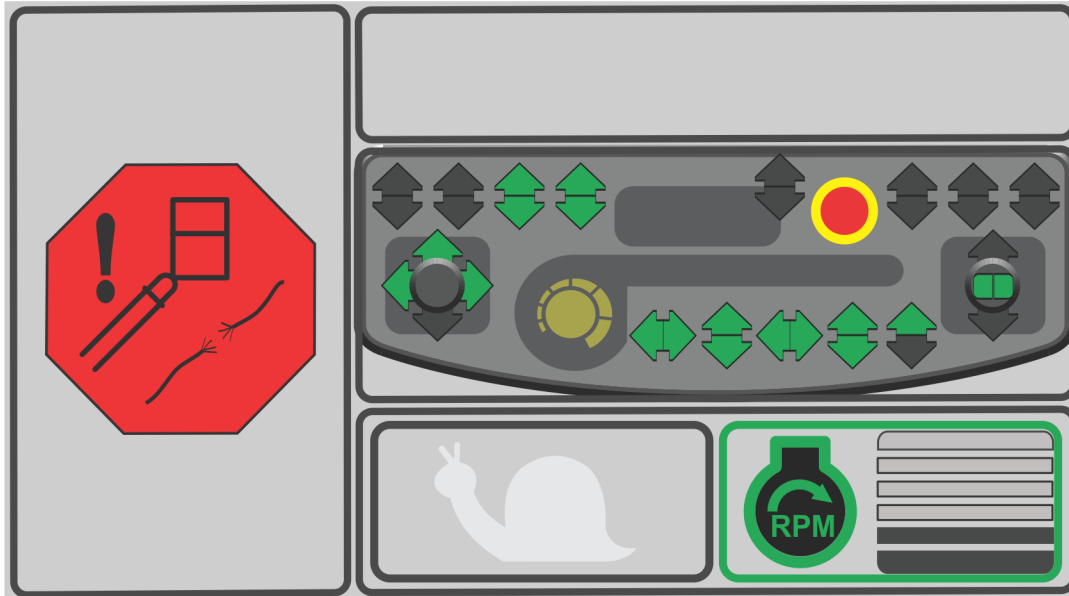

Figure 5-13. Wire Rope Service Screen

5.11 PLATFORM LEVEL

Whenever the control system senses a DTC with the platform level, the platform level lamp is lit on the platform console. When

this lamp is lit, the display shows a red octagon platform level DTC indicator in the machine status tray.

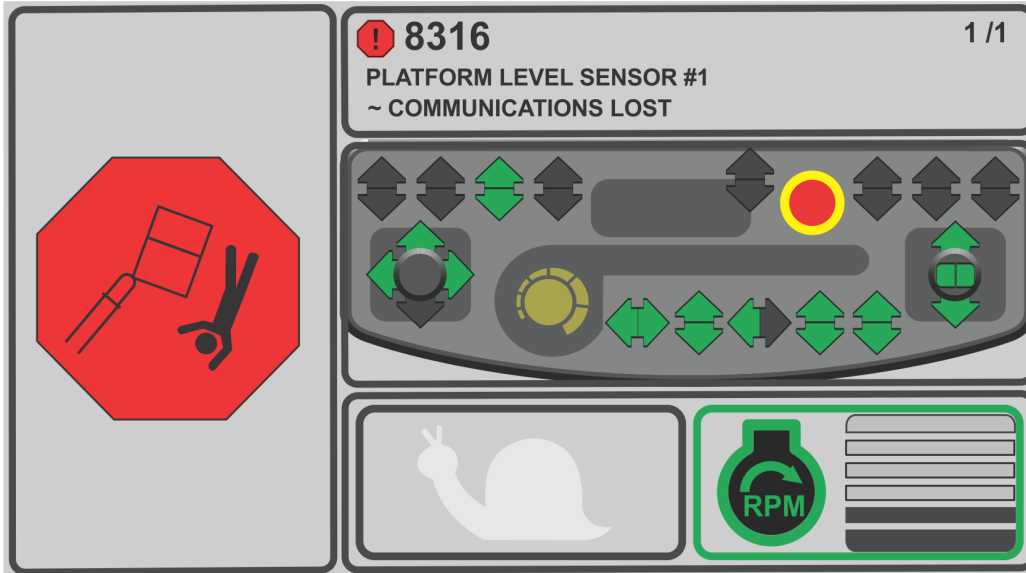

Figure 5-14. Level System DTC Screen

5.12 PLATFORM OVERLOAD

When the boom control system senses that the platform is overloaded, the Platform Overload indicator on the platform console will be lit.

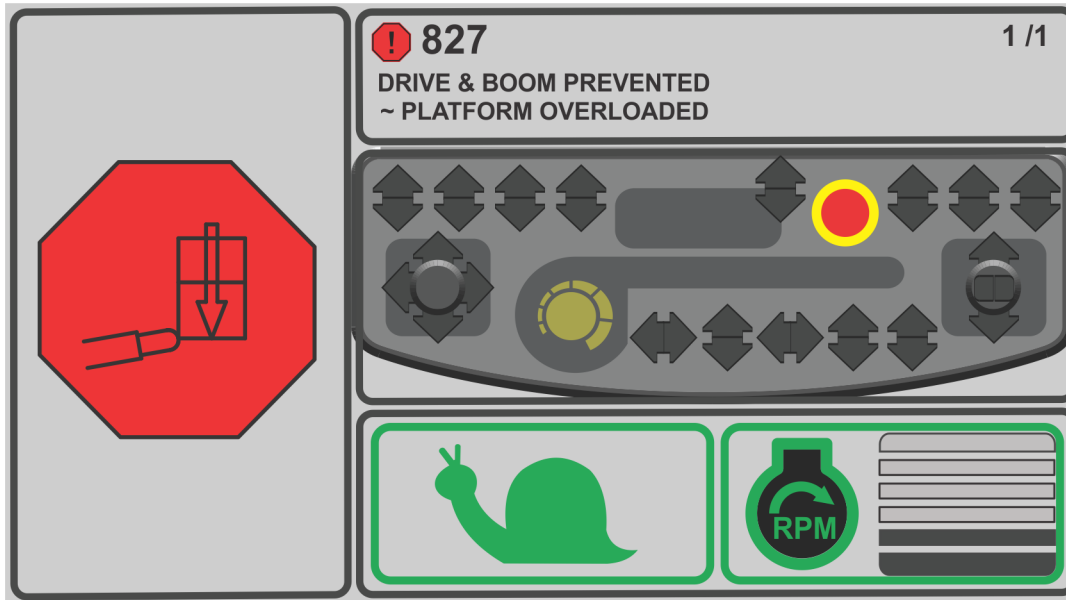

Figure 5-15. Overload DTC Screen

5.13 CAPACITY MODE ERROR

If the operator selects the incorrect capacity mode for the jib configuration (i.e., if the operator is in Unrestricted mode with the jib

completely telescoped out, and changes the capacity to Restricted mode), the capacity mode indicator icon will flash in the Machine Status tray every second.

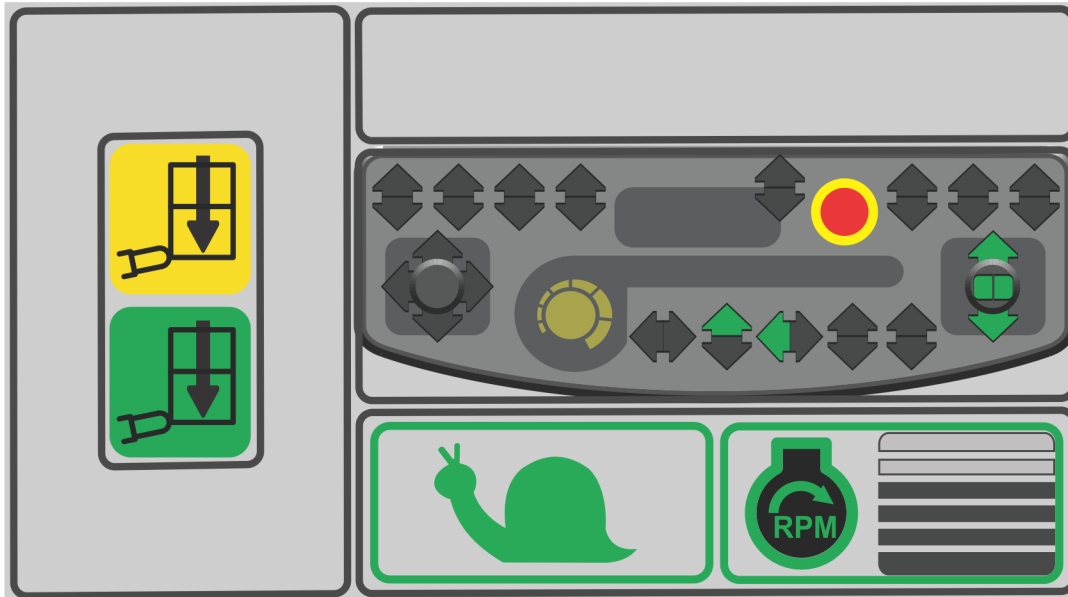

Figure 5-16. Capacity Mode Error Screen

5.14 CHASSIS STATUS

Axles Retracted In Transport Position

When the axles are retracted regardless of engine state, the display shows the following screen. The Axles Retracted image is

shown on the left side of the display or machine status tray. This image will be shown until the axles are extended.

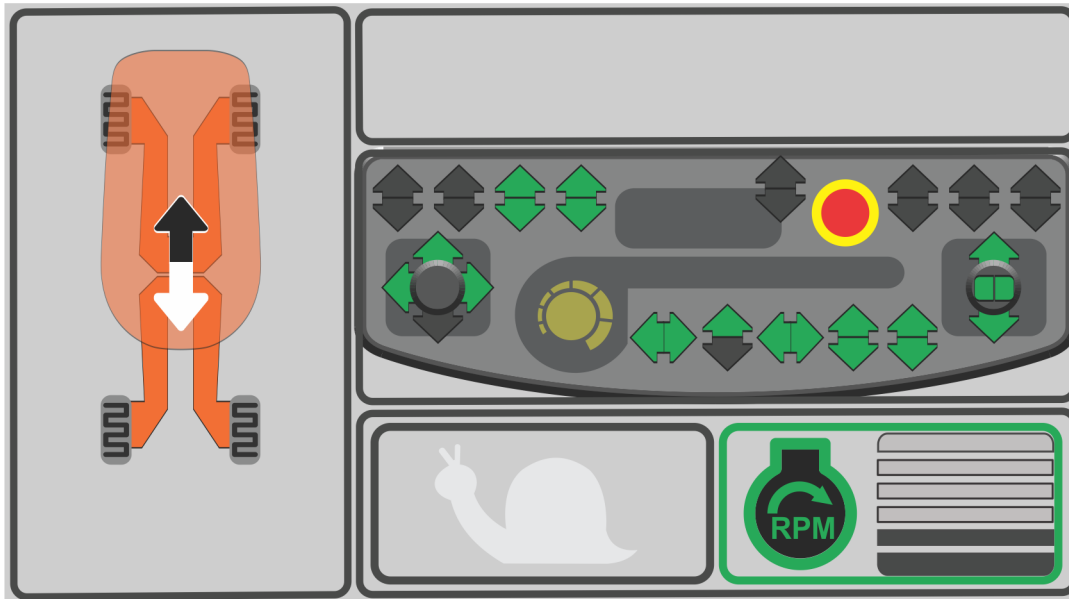

Figure 5-17. Axles Retracted Screen

Axles Extended

When the axles are extended for the first time (meaning previous state is retracted and current state is extended), regardless of the

Engine state, the Axles Extended image will show up on the machine status tray for first 3 seconds.

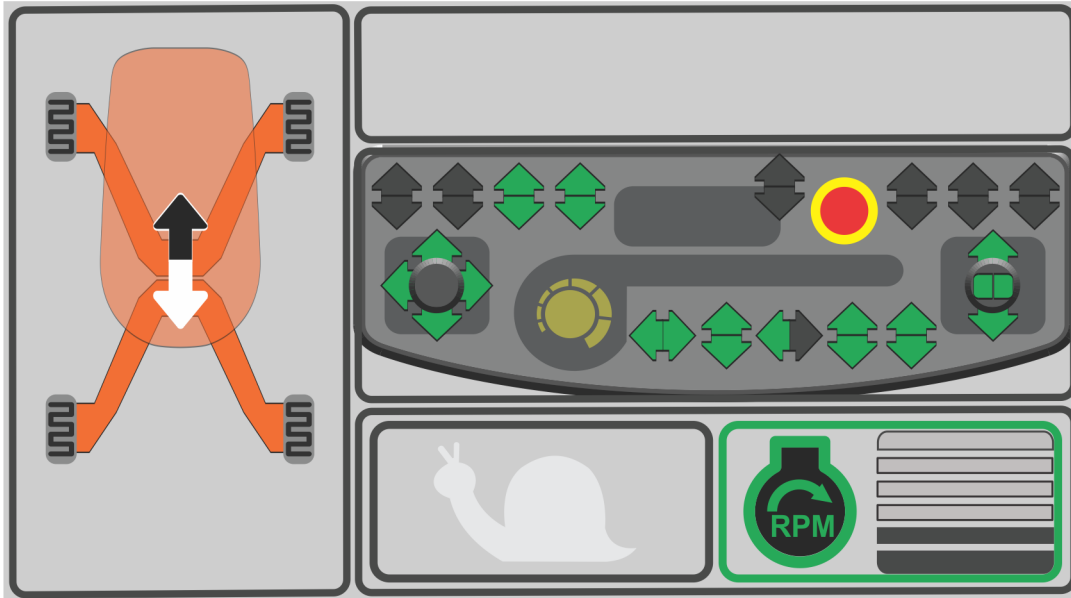

Figure 5-18. Axles Extended Screen

Axles Retracted In Out of Transport Position

When the axles are retracted and the machine is in out of transport position, the display will switch between axles extended and retracted every 0.5 seconds to tell the operator to extend the axles so the boom can be raised.

Axles In Transient State

When the operator is extending or retracting the axles, the Axles In Transient State screen will show and the arrows showing axle travel direction will flash. When the axles are not fully extended or retracted and no axle functions are selected, the green arrows will show steadily.

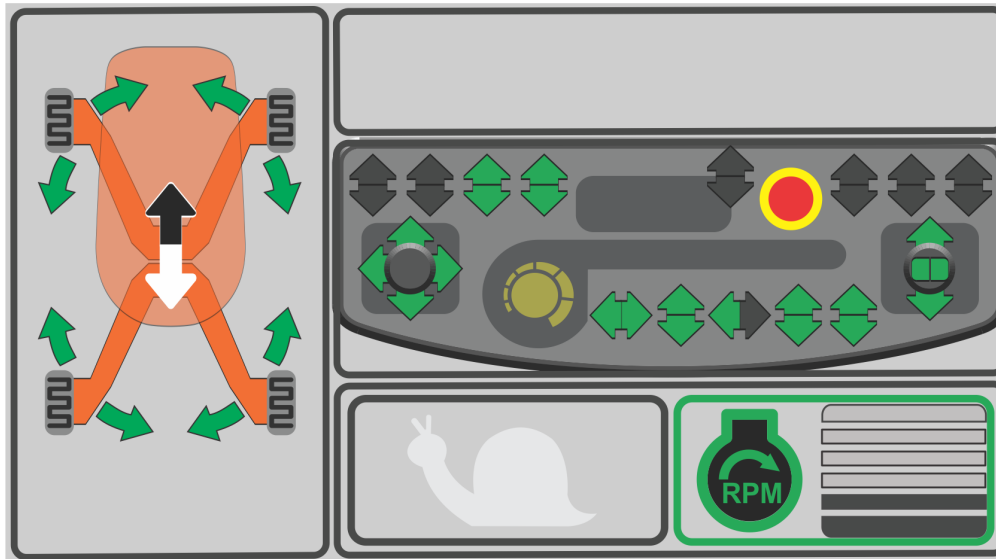

Figure 5-19. Axles In Transient State Screen

5.15 MACHINE TILTED MODE

When the control system senses the chassis is on an excessive slope, the display will show the Machine Tilted image in the machine status tray.

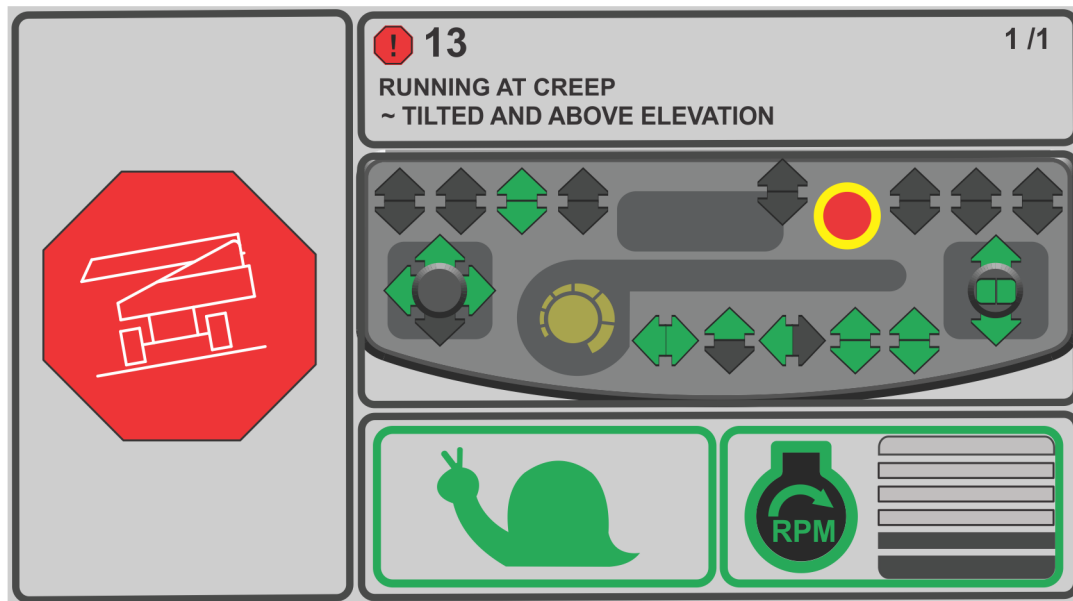

Figure 5-20. Machine Tilted Mode Screen

5.16 ENVELOPE STATUS

Mode	Boom	Platform	Envelope Color
Unrestricted	Orange	Black	Yellow
Restricted	Orange	Black	Green

Example 1: Platform is not at the edge of the envelope

- When Unrestricted or Restricted mode is selected, the display shows envelope image in the machine status tray.
- The color code for the envelope matches the capacity select decals on the machine.
- When the control system senses that the axles are fully extended, the selected envelope shows up on the machine status tray.
- The display shows animated boom length and boom angle information along with the envelope.
- Boom movement is proportional to the envelope boundaries.
- Platform location is always shown at the end of the boom.
- When operator switches from Unrestricted to Restricted mode, the envelope shrinks to indicate reduced operating envelope.

Example 2: Platform is edge of the envelope

- When Unrestricted or Restricted mode is selected, the display flashes snail image at a rate of 0.5 seconds in the machine status tray.
- The envelope color will match the weight mode selected.

Example 3: Unrestricted mode with envelope tilt condition

- When on the Unrestricted envelope screen, if the operator experiences a tilt condition where tilt is less than what the machine is configured for, then the envelope will shrink further to show that the new envelope.
- Display shows animated boom length and boom angle information along with the new envelope.
- Boom movement is proportional to envelope boundaries.
- Platform location is always at the end of the boom.

Example 4: Restricted mode with envelope tilt condition

- When on the Restricted envelope screen, if the operator experiences a tilt condition where tilt is less than what the machine is configured for, then the envelope will shrink further to show that the new envelope.
- Display shows animated boom length and boom angle information along with the new envelope.
- Boom movement is proportional to envelope boundaries.
- Platform location is always at the end of the boom.

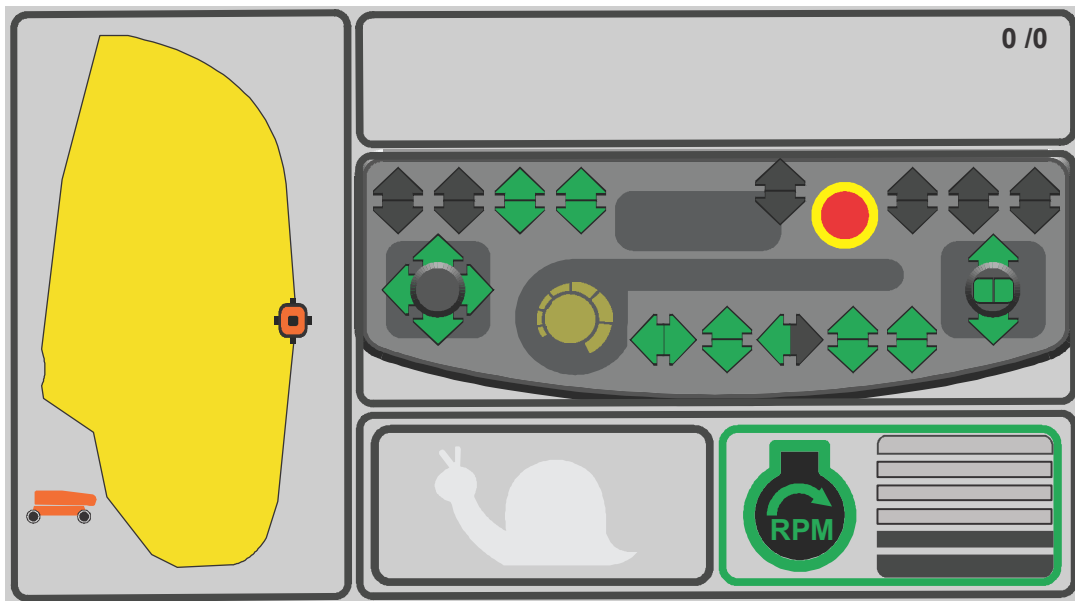

Figure 5-21. Unrestricted Mode Screen

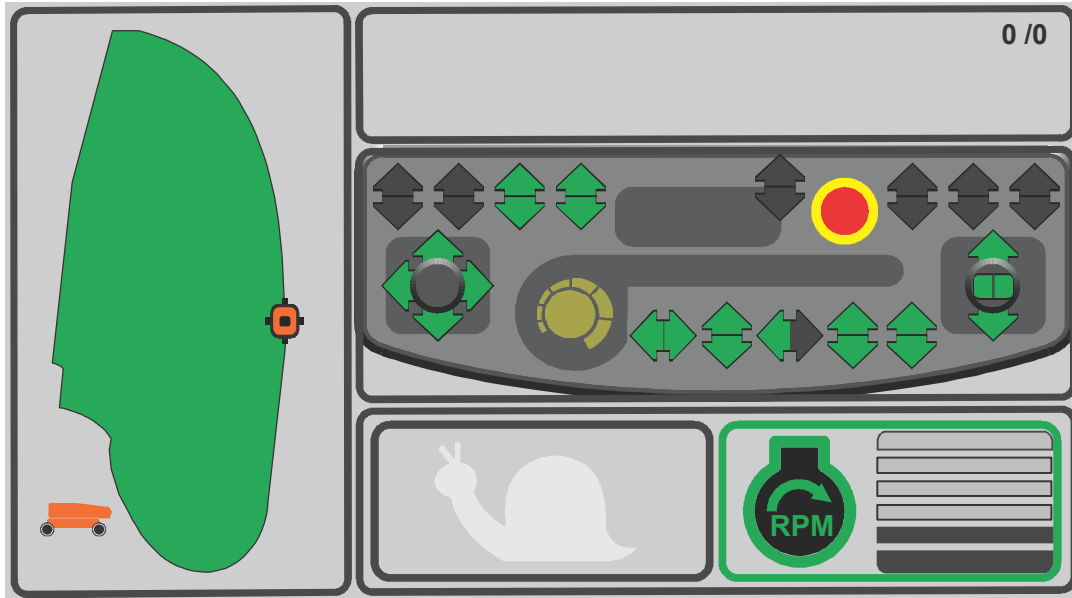

Figure 5-22. Restricted Mode Screen

5.17 MACHINE MODEL UNKNOWN

As soon as the machine is powered up, the control system checks the model of the machine and if the model is neither 1500AJP,

1500SJ, nor 1850SJ the display will show the Machine Model Unknown image on the machine status tray.

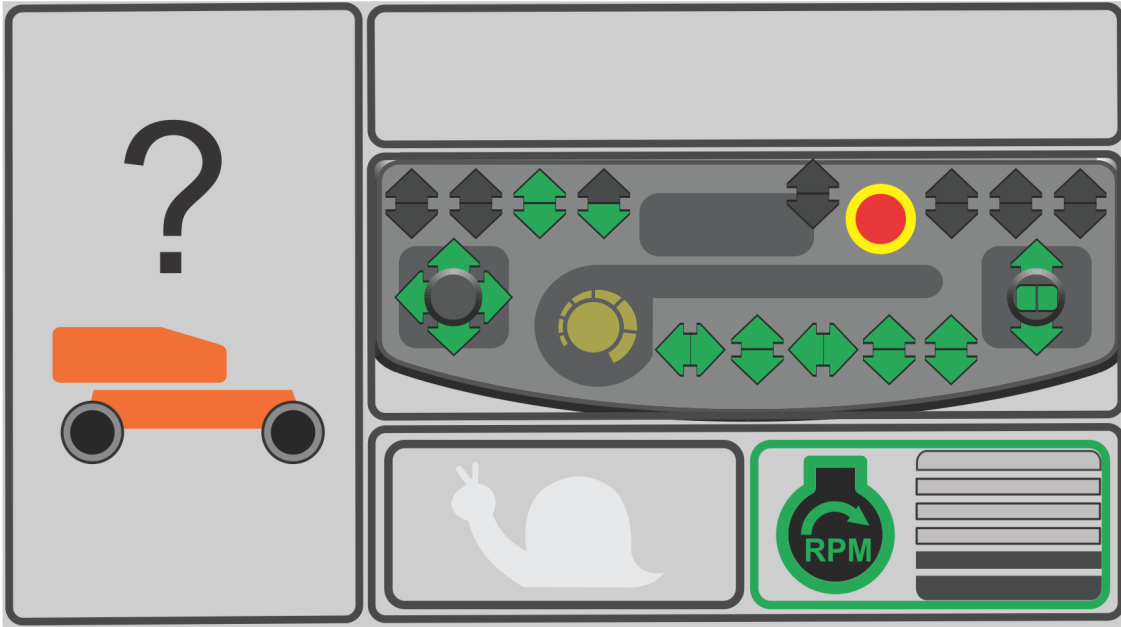

Figure 5-23. Machine Model Unknown Screen

5.18 SELECTIVE CATALYTIC REDUCTION (SCR) CLEANING

SCR icons will display in the icons tray when there is an cleaning event or warning active. The SCR Warning Icon will display when cleaning is required. Refer to Section 4 for more information. The SCR Cleaning Icon will display when:

- JLG Control System requests cleaning
- Crystallization is detected
- The machine is in cleaning mode
- Cleaning process has failed

The High Exhaust System Temperature (HEST) will show in the icons tray when exhaust temperature reaches 1022° F (550° C) degrees. The Diesel Exhaust Fluid (DEF) icon displays the level of fluid in the DEF tank in 1% increments.

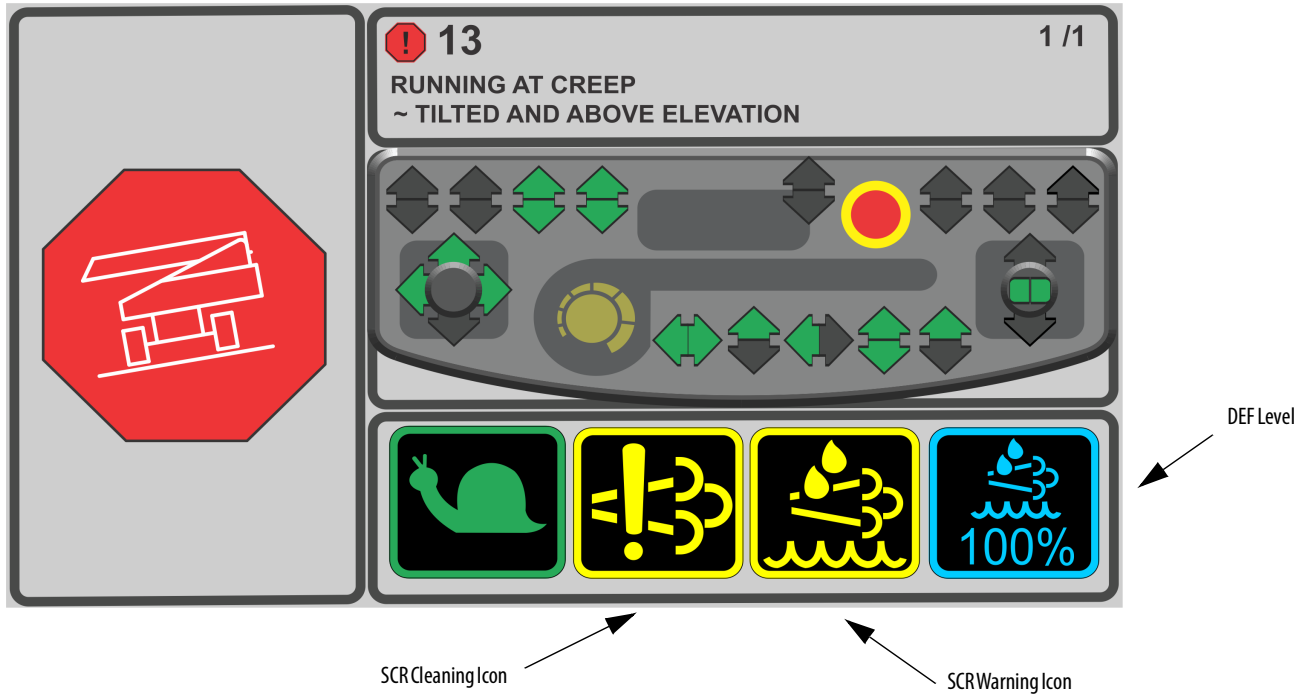

Figure 5-24. SCR Cleaning Screen - Sheet 1 of 2

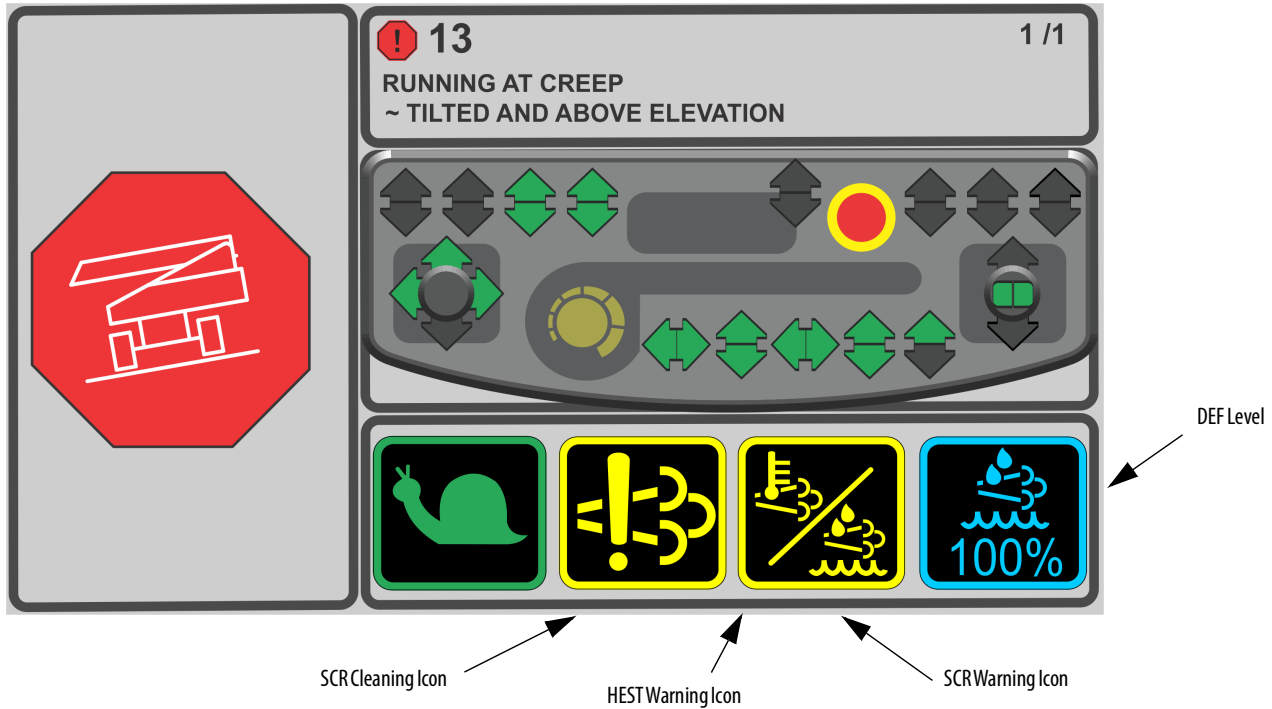

Figure 5-25. SCR Cleaning Screen - Sheet 2 of 2

SECTION 6. EMERGENCY PROCEDURES

6.1 GENERAL

This section explains the steps to be taken in case of an emergency situation while operating.

6.2 INCIDENT NOTIFICATION

JLG Industries, Inc. must be notified immediately of any incident involving a JLG product. Even if no injury or property damage is evident, the factory should be contacted by telephone and provided with all necessary details.

- USA: 877-JLG-SAFE (554-7233)
- EUROPE: (32) 0 89 84 82 20
- AUSTRALIA: (61) 2 65 811111
- E-mail: ProductSafety@JLG.com

Failure to notify the manufacturer of an incident involving a JLG Industries product within 48 hours of such an occurrence may void any warranty consideration on that particular machine.

NOTICE

FOLLOWING ANY ACCIDENT, THOROUGHLY INSPECT THE MACHINE AND TEST ALL FUNCTIONS FIRST FROM THE GROUND CONTROLS, THEN FROM THE PLATFORM CONTROLS. DO NOT LIFT ABOVE 3 M (10 FT.) UNTIL YOU ARE SURE THAT ALL DAMAGE HAS BEEN REPAIRED, IF REQUIRED, AND THAT ALL CONTROLS ARE OPERATING CORRECTLY.

6.3 EMERGENCY OPERATION

Operator Unable to Control Machine

IF THE PLATFORM OPERATOR IS PINNED, TRAPPED OR UNABLE TO OPERATE OR CONTROL MACHINE:

1. Other personnel should operate the machine from ground controls only as required.
2. Other qualified personnel on the platform may use the platform controls. DO NOT CONTINUE OPERATION IF CONTROLS DO NOT FUNCTION PROPERLY.
3. Cranes, forklift trucks or other equipment can be used to remove platform occupants and stabilize motion of the machine.

Platform or Boom Caught Overhead or Boom Movement Prevented by Boom Control System

Lowering the boom onto an object or structure may cause the boom control system to prevent movement of the machine. This can include movement necessary to lift the boom off the object. Additionally, if the platform or boom becomes jammed or snagged in overhead structures, movement of the boom can be regained by doing the following:

1. Shut off the machine.
2. Rescue all people in the platform before freeing the machine. Personnel must be out of the platform before operating any controls on the machine.
3. Use cranes, forklifts, or other equipment to stabilize motion of the machine to prevent a tip over as required.
4. From the ground controls, use the Auxiliary Power System to carefully free the platform or boom from the object.
5. Once clear, restart the machine and return the platform to a safe position.
6. Inspect the machine for damage. If the machine is damaged or does not operate properly, turn off the machine immediately. Report the problem to the proper maintenance personnel. Do not operate the machine until it is declared safe for operation.

6.4 EMERGENCY TOWING PROCEDURES

Towing this machine is prohibited, unless properly equipped. However, provisions for moving the machine have been incorporated. For specific procedures, refer to Section 4.

6.5 MACHINE SAFETY SYSTEM OVERRIDE (MSSO) (IF EQUIPPED)

The Machine Safety System Override (MSSO) is only to be used to retrieve an operator that is pinned, trapped, or unable to operate the machine and function controls are locked out from the platform due to a platform overload situation.



NOTE: *If the MSSO functionality is used, the fault indicator will flash and a fault code is set in the JLG Control System which must be reset by a qualified JLG Service Technician.*

NOTE: *No functional checks of the MSSO system are necessary. The JLG Control system will set a Diagnostic Trouble Code if the control switch is faulty.*

To operate the MSSO:

1. From the ground control console, place the Platform/ Ground Select switch in the Ground position.
2. Pull out the Power/Emergency Stop control.
3. Start the engine.
4. Press and hold the MSSO switch and the control switch for the desired function.

SECTION 6 - EMERGENCY PROCEDURES

SECTION 7. ACCESSORIES

Table 7-1. Available Accessories

Accessory	Market						
	ANSI (USA Only)	ANSI	CSA	CE	AUS	Japan	China
SkyPower™ - 7.5 kW	√	√	√		√	√	√
Generator - 4 kW	√	√	√	√	√	√	√
SkyWelder™	√	√	√		√	√	√
Pipe Rack	√				√		
Soft Touch	√	√	√	√	√	√	√
SkyGlazier™	√	√	√	√	√		
SkyCutter	√	√	√			√	
SkySense™	√	√	√	√	√	√	√
Fall Arrest Platform (36x96)	√	√	√			√	√
Fall Arrest Platform (36x72)	√	√	√				
Bolt-On External Fall Arrest (36x96)	√	√	√			√	√
Bolt-On External Fall Arrest (36x72)	√	√	√			√	√

SECTION 7 - ACCESSORIES

Table 7-2. Options/Accessories Relationship Table

ACCESSORY	REQUIRED ITEM	COMPATIBLE WITH (note 1)	INCOMPATIBLE WITH	INTERCHANGABLE WITH (note 2)
SkyPower™		SkyGlazier™, SkyWelder™, SkyCutter™		
SkyWelder™	SkyPower™	SkyCutter™	Soft Touch, SkySense™, Pipe Jacks/Racks, Platform Mesh to Top Rail, 4' Platform	SkyGlazier™
SkyGlazier™		SkyPower™	Pipe Jacks/Racks, Soft Touch, SkySense™, Platform Mesh to Top Rail, 4' Platform	SkyWelder™, SkyCutter™
SkyCutter™	SkyPower™	SkyWelder™	Soft Touch, SkySense™ Platform Mesh to Top Rail, Pipe Jacks/Racks, 4' Platform	SkyGlazier™
SkySense™			Soft Touch, SkyGlazier™, SkyWelder™, SkyCutter™, Pipe Jacks/Racks, Platform Mesh to Top Rail, Platform Mesh to Mid Rail	
Pipe Jacks / Racks		SkyPower™	Platform Mesh to Mid Rail, Platform Mesh to Top Rail, Soft Touch, SkySense™	SkyWelder™, SkyCutter™, SkyGlazier™
Note 1: Any non "Sky" accessory, not listed under "INCOMPATIBLE WITH", are compatible				
Note 2: Can be used on same unit but not simultaneously.				

4150491L

⚠ WARNING

INSTALLING OR REMOVING APPROVED ACCESSORIES OR CHANGING PLATFORM SIZE REQUIRES RECALIBRATION OF THE BOOM CONTROL SYSTEM (SEE SERVICE AND MAINTENANCE MANUAL).

7.1 SKYPOWER™ 7.5 KW AND GENERATOR 4 KW

The SkyPower™ and generator systems supply AC power through an AC receptacle in the platform to run tools, lights, and cutting and welding equipment. All power regulation components are located in a watertight box connected by cable to the generator. The generator supplies power when running at the specified speed with the power switch on (switch is located on platform). A two-pole, 20 A (4 kW) or a three-pole, 30 A (7.5 kW) circuit breaker protects the generator from overload.

Output

SkyPower 7.5 kW Specifications:

- 3-phase: 240 V, 60 Hz, 7.5 kW (Peak: 8.5 kW)
- 1-phase: 240 V/120 V, 60 Hz, 6 kW (Peak: 6 kW)

Generator 4 kW Specifications:

- 1-phase: 240 V/120 V, 60 Hz, 4 kW
- 1-phase: 230 V/115 V, 50 Hz, 4 kW

Accessory Ratings

- 3000 rpm (50 Hz)
- 3600 rpm (60 Hz)

Safety Precautions

- Do not over load platform.
- Make sure no personnel are beneath platform.
- Keep lanyard attached at all times.
- Do not use electrical tools in extremely wet conditions.
- Use correct voltage for tool being used.
- Do not over load circuit.

Preparation and Inspection

- Ensure generator is secure, check condition of belt and wiring.

Operation

Start engine, turn on generator, begin using.

Refer to the Miller Generator Technical Manual (PN 3121677) for more information.

7.2 SKYWELDER™

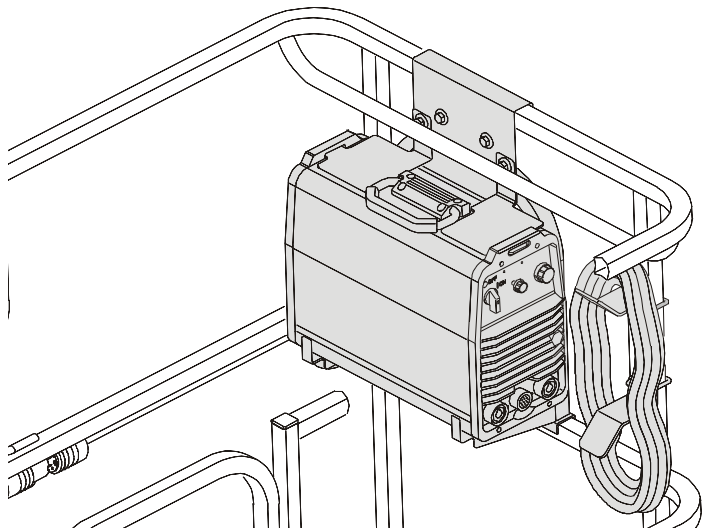

SkyWelder™ is capable of TIG and Stick welding, producing 200 Amps at 100% duty cycle or 250 Amps at 50% duty cycle. This accessory receives power from the SkyPower™ system.

Generator Output

Engine Speed of 1800 rpm +/- 10%.

ANSI Specifications:

- 3-phase: 240 V, 60 Hz, 7.5 kW
- 1-phase: 240 V/120 V, 60 Hz, 6 kW

Welding Accessories

- 12 ft welding leads with clamp and stinger (stored in the platform)
- Fire extinguisher

Accessory Ratings

Table 7-3. Welding Characteristics

Welding Mode	Input Power	Rated Output	Welding Amperage Range	Maximum Open Circuit Voltage	Amps Input At Rated Load Output. 50/60 Hz				
					230 V	460 V	575 V	KVA	KW
Stick (SMAW) TIG (GTAW)	3-Phase	280 Amp at 31.2V. 35% Duty Cycle	5-250A	79VDC	30.5	17	13	15.7	10
		200 Amp at 28V. 100% Duty Cycle			20	11	8	10.3	6.4
	1-Phase	200 Amp at 28V. 50% Duty Cycle	5-200 A	70VDC	35	-----	-----	9.8	6.5
		150 Amp at 28V. 100% Duty Cycle			34	-----	-----	6.9	4.4

Safety Precautions



WARNING

DO NOT OVERLOAD PLATFORM.



WARNING

DE-RATE THE PLATFORM BY 70 LB (32 KG) WHEN WELDER IS IN THE PLATFORM.

- Check for cracked welds and damage to welder supports.
- Check for proper and secure installation of welder and bracket.
- Be certain no personnel are beneath platform.
- Do not exit platform over rails or stand on rails.
- Keep lanyard attached at all times.
- Ensure correct polarity of leads.
- Use proper welding apparel.

SECTION 7 - ACCESSORIES

- Use correct rod size and current settings.
- Do not use electrical cords without ground.
- Do not use electrical tools in water.
- Do not weld to platform.
- Do not ground through the platform.
- Do not use a high frequency arc starter with TIG welder.

Preparation and Inspection

Connect ground clamp to metal being welded, make sure there is a good ground connection and observe proper polarity, begin welding.

Operation

Start engine turn on generator then turn on welder.

Wear proper welding apparel. Set welder to proper amperage and voltage settings for thickness and type of metal being welded. Begin welding.

Refer to the Miller Welder Owner's Manual (PN 3128957) for more information.

Generator will not start under an electrical load.

7.3 PIPE RACKS

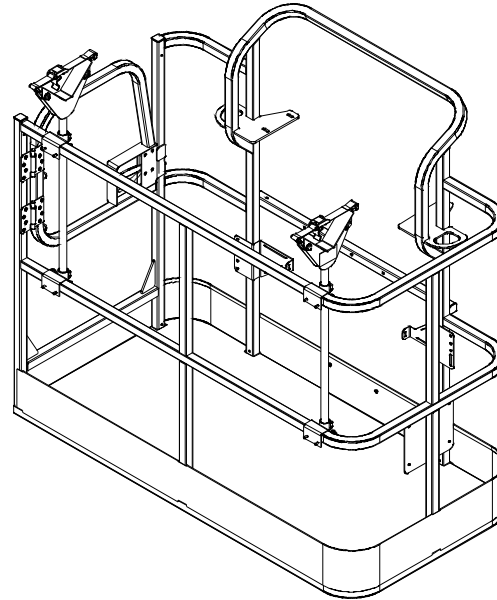

Pipe Racks provide a way to store pipe or conduit inside the platform in order to prevent rail damage and optimize platform utility. This accessory consists of two racks with adjustable straps to secure the load in place.

Capacity Specifications (Australia Only)

Max. Capacity in Racks *	Max. Platform Capacity (With Max. Weight in Racks)
80 kg	184 kg
Max. Length of Material in Racks: 6.0 m Min. Length of Material in Racks: 2.4 m	

Safety Precautions

WARNING

REDUCE PLATFORM CAPACITY BY 100 LB (45.5 KG) WHEN INSTALLED.

WARNING

WEIGHT IN RACKS PLUS WEIGHT IN PLATFORM MUST NOT EXCEED RATED CAPACITY.

NOTICE

THE MAXIMUM LOAD IN THE RACKS IS 180 LB (80 KG) EVENLY DISTRIBUTED BETWEEN THE TWO RACKS.

NOTICE

THE MAXIMUM LENGTH OF MATERIAL IN RACKS IS 20 FT (6.1 M).

- Ensure no personnel are beneath the platform.
- Do not exit platform over rails or stand on rails.
- Do not drive machine without material secured
- Return racks to the stowed position when not in use.
- Use this option only on approved models.

Preparation and Inspection

- Ensure racks are secured to the platform rails.
- Replace torn or frayed tie-down straps.

Operation

1. To prepare racks for loading, remove locking pins, rotate each rack 90 degrees from stowed to working position, then secure with locking pins.
2. Loosen and remove tie-down straps. Place material on racks with weight evenly distributed between both racks.
3. Route the tie-down straps at each end across loaded material and tighten.
4. To remove material, loosen and remove tie-down straps, then carefully remove material from racks.

NOTE: Reinstall tie-down straps across any remaining material before continuing machine operations.

7.4 SOFT TOUCH

A padding kit is mounted to the platform rails and to a frame suspended below the platform. Limit switches deactivate platform functions when the padded framework contacts an adjacent structure. A button on the platform console allows override of the system.

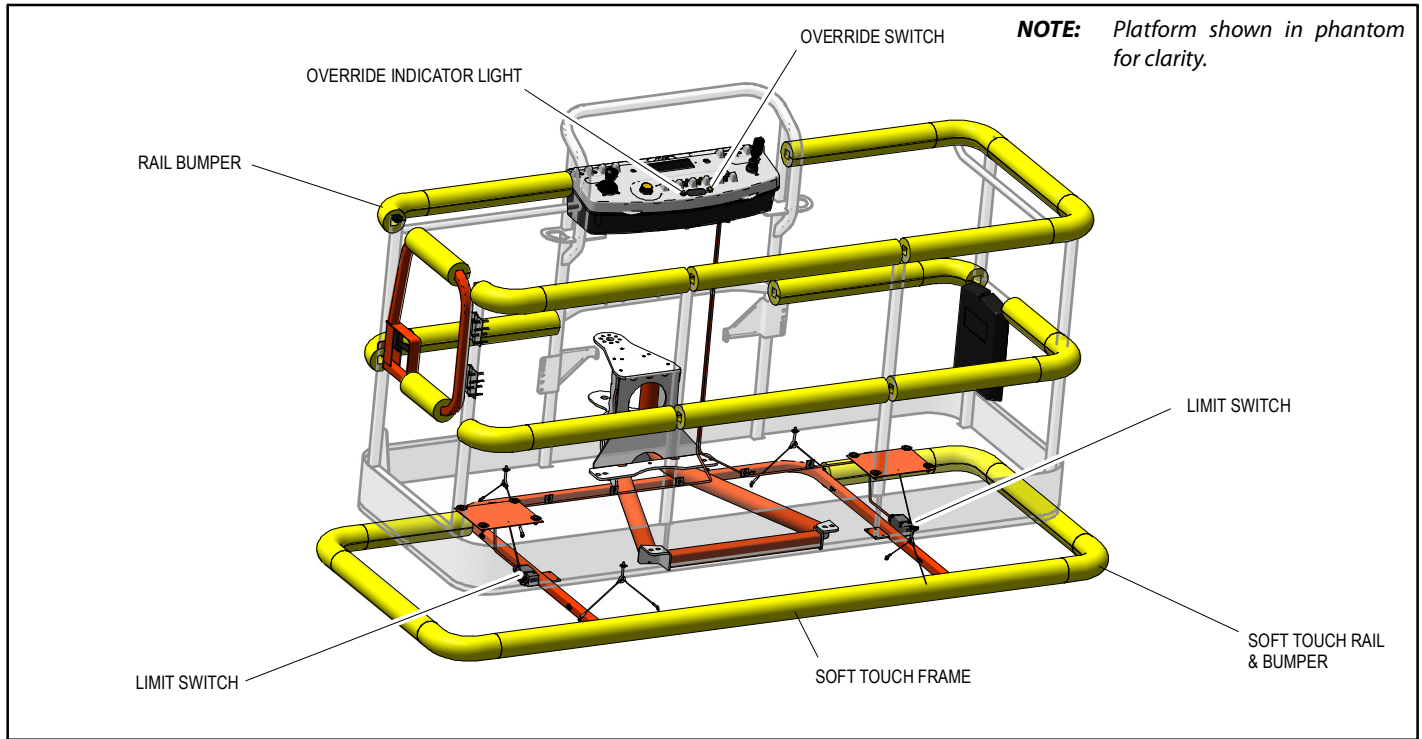
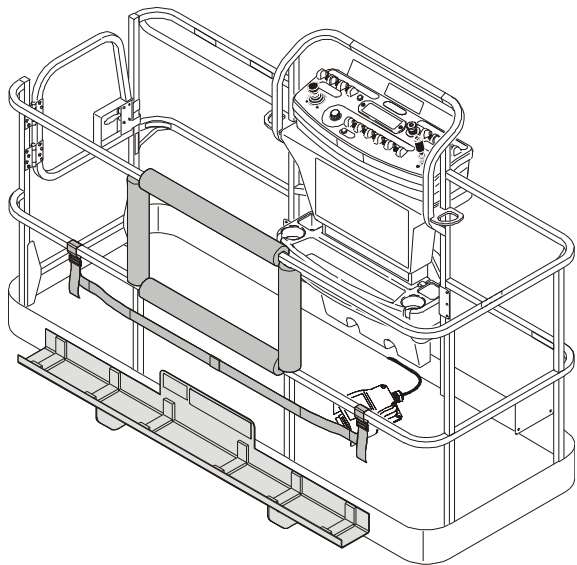

Figure 7-1. Soft Touch

7.5 SKYGLAZIER™



SkyGlazier™ allows glaziers to position panels efficiently. The glazier package consists of a tray that attaches the bottom of the platform. The panel rests on the tray and against top-rail of the platform, which is padded to prevent damage. SkyGlazier™ includes a strap to secure the panel to the platform rail.

Capacity Specifications

Capacity Zone *	Max. Tray Capacity	Max. Platform Capacity (With Max. Weight in Tray)
500lb (227 kg)	150lb (68 kg)	250lb (113 kg)
550lb (250 kg)	150lb (68 kg)	250lb (113 kg)
600lb (272 kg)	150lb (68 kg)	250lb (113 kg)
750lb (340 kg)	150lb (68 kg)	440lb (200 kg)
1000lb (454 kg)	250lb (113 kg)	500lb (227 kg)
* Refer to the capacity decals installed on the machine for capacity zone information.		
Required Platform Type: Side-Entry		
Max. Dimensions of Panel: 32 sq.ft. (3 sq.m.)		

Safety Precautions

⚠ WARNING

ENSURE PANEL IS SECURED WITH STRAP.

⚠ WARNING

DO NOT OVERLOAD TRAY OR PLATFORM. TOTAL MACHINE CAPACITY IS REDUCED WHEN TRAY IS INSTALLED.

⚠ WARNING

WITH SKYGLAZIER™ INSTALLED, THE ORIGINAL PLATFORM CAPACITY RATINGS ARE REDUCED AS SPECIFIED IN THE CAPACITY SPECIFICATIONS TABLE. DO NOT EXCEED NEW PLATFORM CAPACITY RATINGS. REFER TO CAPACITY DECAL LOCATED ON TRAY.

⚠ WARNING

AN INCREASE OF THE AREA EXPOSED TO THE WIND WILL DECREASE STABILITY. LIMIT PANEL AREA TO 32 SQ.FT. (3 SQ.M).

- Ensure no personnel are beneath platform.
- Do not exit platform over rails or stand on rails.
- Remove tray when not in use.
- Use this option only on approved models.

Preparation and Inspection

- Check for cracked welds and damage to tray.
- Ensure tray is properly secured to platform.
- Ensure strap is not torn or frayed.

Operation

1. Load SkyGlazier™ tray with panel.
2. Route the adjustable strap around the panel and tighten until secure.
3. Position panel to its desired location.

7.6 SKYCUTTER™

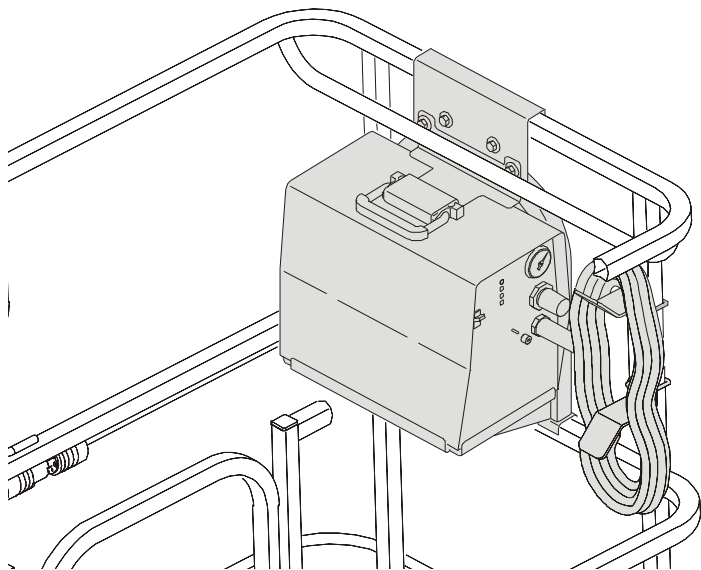

SkyCutter™ is capable of cutting up to a thickness of 3/8" metal. It can produce 27 A at 92 VDC at 35% duty cycle or 14 A at 92 VDC at 60% duty cycle. It receives power from the SkyPower™ system.

Safety Precautions

⚠ WARNING

DO NOT OVERLOAD PLATFORM.

⚠ WARNING

DE-RATE THE PLATFORM BY 70 LB (32 KG) WHEN PLASMA CUTTER IS IN PLATFORM.

- Check for cracked welds and damage to plasma supports.
- Check for secure installation of cutter and bracket.
- Ensure no personnel are beneath platform.
- Do not exit platform over rails or stand on rails.
- Use this option only on approved models.
- Keep lanyard attached at all times.
- Use correct cutting settings.
- Do not use electrical cords without ground.
- Do not use electrical tools in water.
- Do not cut platform, or ground through the platform.
- Wear proper cutting apparel.
- Do not drive machine while connected to external air/gas sources.

Accessory Ratings

Spec.	Rated Output	Amperes Input @ Rated Output, 60 Hz, 1-Phase	kVa/kW	Plasma Gas	Plasma Gas Flow/ Pressure	Rated Cutting Capacity @ 10 IPM	Max. OCV
120Volts ±10% (20A)	27 A @ 91VDC @ 20% Duty Cycle	28.8 max; 0.30*	3.4kVa 3.2kW	Air or Nitrogen Only @ 90 - 120 psi (621 - 827 kPa)	4.5 cfm (129L/Min) @ 60psi (414 kPa)	3/8 in (10 mm)	400VDC
120Volts ±10% (15A)	20 A @ 88VDC @ 35% Duty Cycle	20.6 max; 0.30*	2.5 kVa 2.3 kW				
240Volts ±10% (27A)	27 A @ 91VDC @ 35% Duty Cycle	13.9 max; 0.13*	3.3 kVa 3.0kW				
*While idling.							

Generator Output

Engine Speed of 1800 rpm +/- 10%.

ANSI Specifications:

- 3-phase: 240 V, 60 Hz, 7.5 kW
- 1-phase: 240 V/120 V, 60 Hz, 6 kW

Preparation and Inspection

- Connect ground clamp to metal being cut.
- Ensure there is a good ground connection.

Operation

Start the engine, turn on the generator, then turn on the plasma cutter.

Refer to the Miller Plasma Cutter Owner’s Manual (PN 3128420) for more information.

7.7 SKYSENSE™

WARNING

SKYSENSE IS NOT INTENDED TO REPLACE OR REDUCE THE NEED FOR THE OPERATOR TO BE AWARE OF THE ENVIRONMENT AROUND THE MACHINE. HAZARDS THAT WILL CAUSE SERIOUS INJURY OR DEATH MAY NOT BE PREVENTED OR REDUCED BY SKYSENSE. THE OPERATOR MUST ALWAYS LOOK IN THE DIRECTION OF TRAVEL, AVOID POWER LINES, AVOID OBSTACLES THAT COULD STRIKE THE MACHINE OR PERSONS IN THE PLATFORM, AND FOLLOW ALL INSTRUCTIONS, DECALS, AND OTHER WARNINGS PROVIDED WITH THIS MACHINE.

THE OPERATOR MUST NOT RELY ON SKYSENSE AS A SUBSTITUTE FOR FOLLOWING THE INSTRUCTIONS AND WARNINGS CONTAINED IN THE MANUALS AND PLACARDS PROVIDED WITH THIS MACHINE.

SKYSENSE IS INTENDED TO ASSIST THE OPERATOR. SKYSENSE MAY NOT DETECT CERTAIN OBJECTS DEPENDING ON SHAPE, TYPE OF MATERIAL, OR ORIENTATION OF THE OBJECT TO THE SENSORS. IT IS THE OPERATOR'S RESPONSIBILITY TO BE AWARE OF THEIR SURROUNDINGS AT ALL TIMES.

WARNING

DE-RATE THE PLATFORM BY 10 LB (4.5 KG) PER BAR WHEN INSTALLED ON THE PLATFORM (20 LB (9 KG) OR 30 LB (14 KG) TOTAL).

NOTE: *SkySense is not active when operating the machine from the ground controls.*

Preparation and Inspection

Pre-Operation Inspection:

1. Inspect each of the SkySense tubes for dents, cracks, or other damage.
2. Inspect each SkySense sensor for any damage to the housing or sensor.

To test the SkySense system:

1. In an area free of obstructions, ensure the machine is on a smooth, firm surface within the limits of the maximum operating slope.
2. From the platform control console, elevate the boom until the bottom of the platform is at least 6 feet off the ground.
3. Continue to elevate the platform.
4. While elevating, hold your hand 6 inches to 12 inches above one of the upward facing sensors. The machine should stop, and the LED corresponding to that sensor (left LED for left sensor bar; right LED for right sensor bar; both LEDs for center sensor bar or overhead sensor) should be red.

5. Ensure the area below the platform is clear of obstructions and lower the platform. The machine should slow down, (SkySense Status LED will blink yellow with increasing frequency) and stop, (SkySense Status LED will be illuminated solid red) when the bottom of the platform is approximately 12 inches from the ground. The alarm should sound if it is not muted (refer to SkySense Alarm).
6. Recycle the footswitch and press the override button on the platform control console.
7. Continue to lower the platform. The machine should move in the elevated drive speed mode (SkySense Status LED will remain red).

NOTE: *The SkySense system will not stop machine operation while in Creep.*

Operation

SkySense slows a machine's function to creep speed when it is a certain distance away from an object, known as the "warning zone." If the machine continues to approach the object and moves into the "stop zone," SkySense stops all machine functions.

For proportional functions activated by the joystick, the size of the warning zone varies based on the amount of joystick activation. The stop zone always activates at the same distance from the object regardless of the joystick's position.

If the function has reached the warning zone, normal drive speed will resume when a function is activated in the opposite direction. If the machine has reached the SkySense stop zone, release the function and recycle the footswitch to activate a function in the opposite direction.

SkySense is active during the following functions:

- Lift Up/Down (including jib functions)
- Platform Rotate (including jib rotate)
- Telescope Out
- Swing
- Reverse Drive

SECTION 7 - ACCESSORIES

NOTE: During active DOS (Drive Orientation System), SkySense is active when driving in both forward and reverse directions.

There are two LED indicators on the platform control box that signal SkySense activity.

- **No LED:** Normal operation.
- **LED Flashing Yellow:** Machine is in SkySense warning zone and will reduce function speed to creep. Flash frequency correlates to proximity of object.
- **LED Red:** Machine is in SkySense stop zone and all machine functions will cease.
- **LED Flashing Red:** SkySense sensor is obstructed or damaged. Obstructions must be removed and proper function verified. Damaged sensors must be replaced.

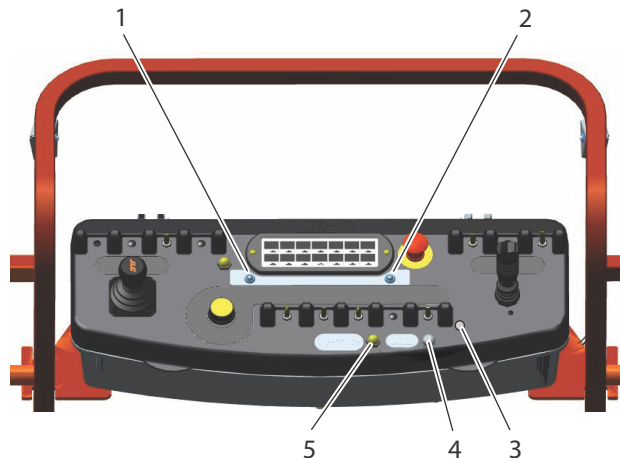

1. LED Indicator Light
2. LED Indicator Light
3. Alternate Mute Speaker Switch Position
4. Mute Speaker Switch
5. Override Button

Figure 7-2. SkySense Platform Panel Indicators

SkySense Alarm

Activation of SkySense is signaled by an audible alarm and the LEDs on the platform console that indicate SkySense activity when reaching the warning or stop zones.

In the warning zone, the audible alarm will pulse and increase in frequency as the machine moves closer to the object. In the stop zone, the alarm will sound a continuous tone.

Additionally, when the machine is in the stop zone, the platform control panel audible alarm will sound. The system may be reset by recycling the footswitch.

The audible SkySense alarms can be muted by a switch on the platform control console, although LEDs will continue to light. The platform control panel alarm will sound when the machine enters the SkySense stop zone even when muted.

NOTE: *If the machine is equipped with headlights/tail lights or chassis illumination lights options AND the SkySense option, the Mute switch will be located in the alternate position (3). See Figure 7-2., SkySense Platform Panel Indicators.*

Override Button

The yellow override button allows operators to bypass normal SkySense operation in order to move closer to an object in the stop zone.

When the operator overrides the SkySense via the override button to get closer to a work surface, the machine will maintain creep speed and flash the appropriate indicator color based on location in either the warning or stop zones.

NOTE: *Override is only required to be engaged if the operator desires to move the platform closer to an object that is in or entering the stop zone.*

SKYGUARD OPERATION IS AFFECTED WHEN SKYSENSE IS INSTALLED ON A MACHINE. IF SKYSENSE ACTIVATION OCCURS PRIOR TO SKYGUARD ACTIVATION, SKYGUARD WILL ONLY CUT OUT FUNCTIONS IF ACTIVATED. IF SKYGUARD ACTIVATION OCCURS PRIOR TO SKYSENSE ACTIVATION, SKYGUARD WILL FUNCTION NORMALLY.

SkySense Coverage Areas

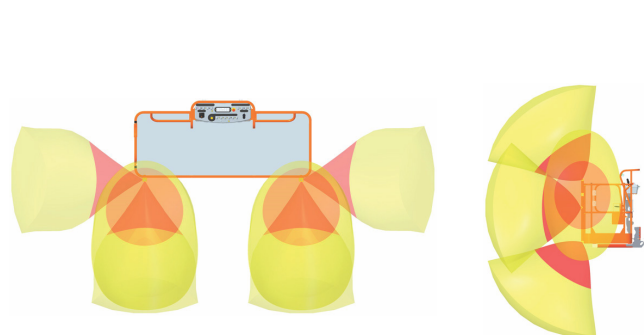

Level 1 (2-Bar)

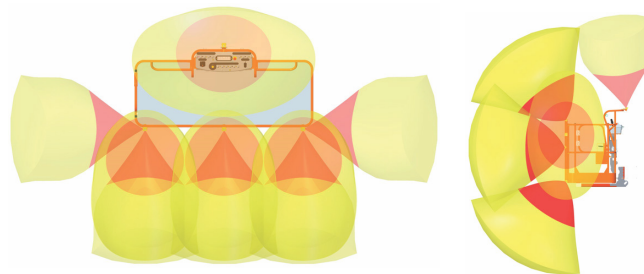

Level 2 (3-Bar)

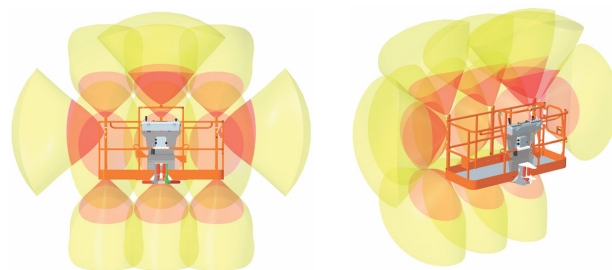

Sensor Cones shown are approximations for reference only.

7.8 FALL ARREST PLATFORM

NOTE: Refer to JLG External Fall Arrest System manual (P/N-3128935) for more detailed information.

The external fall arrest system is designed to provide a lanyard attach point while allowing the operator to access areas outside the platform. Exit/Enter the platform through the gate area only. The system is designed for use by one person.

Personnel must use fall protection at all times. A full body harness is required with lanyard not to exceed 6 ft. (1.8 M) in length, that limits the maximum arrest force to 900 lb (408 kg) for the trans-faster type and 1350 lb (612 kg) for the shuttle type fall arrest system.

WARNING

DO NOT OPERATE ANY MACHINE FUNCTIONS WHILE OUTSIDE OF PLATFORM. BE CAREFUL WHEN ENTERING/EXITING THE PLATFORM AT ELEVATION.

7.9 BOLT-ON EXTERNAL FALL ARREST

The bolt-on external fall arrest system is designed to provide a lanyard attach point while allowing the operator to access areas outside the platform. Exit/Enter the platform through the gate area only. The system is designed for use by one person.

Personnel must use fall protection at all times. A full body harness is required with lanyard not to exceed 6 ft. (1.8 M) in length, that limits the maximum arrest force to 900 lb (408 kg).

External Fall Arrest System capacity is 310 lb (140 kg) - one (1) person maximum.

Do not move platform during use of the external fall arrest system.

WARNING

DO NOT OPERATE ANY MACHINE FUNCTIONS WHILE OUTSIDE OF PLATFORM. BE CAREFUL WHEN ENTERING/EXITING THE PLATFORM AT ELEVATION.

⚠ WARNING

IF THE EXTERNAL FALL ARREST SYSTEM IS USED TO ARREST A FALL OR IS OTHERWISE DAMAGED, THE ENTIRE SYSTEM MUST BE REPLACED AND THE PLATFORM FULLY INSPECTED BEFORE RETURNING TO SERVICE. REFER TO THE SERVICE MANUAL FOR REMOVAL AND INSTALLATION PROCEDURES.

NOTICE

THE EXTERNAL FALL ARREST SYSTEM REQUIRES AN ANNUAL INSPECTION AND CERTIFICATION. THE ANNUAL INSPECTION AND CERTIFICATION MUST BE PERFORMED BY A QUALIFIED PERSON OTHER THAN THE USER.

Inspection Before Use

The external fall arrest system must be inspected before each use of the machine. Replace components if there are any signs of wear or damage.

Before each use, perform a visual inspection of the following components:

- Cable: Inspect cable for proper tension, broken strands, kinks, or any signs of corrosion.

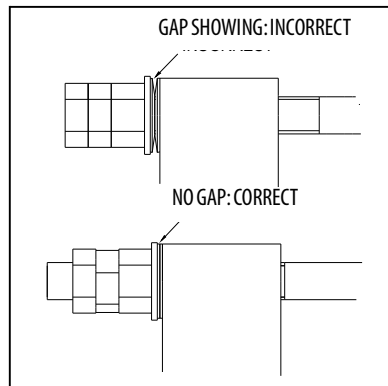

Figure 7-2. Bolt-On External Fall Arrest Cable Tension

- Fittings & Brackets: Ensure all fittings are tight and there are no signs of fractures. Inspect brackets for any damage.
- Attachment Ring: No cracks or signs of wear are acceptable. Any signs of corrosion requires replacement.
- Attaching Hardware: Inspect all attaching hardware to ensure there are no missing components and hardware is properly tightened.
- Platform Rails: No visible damage is acceptable.

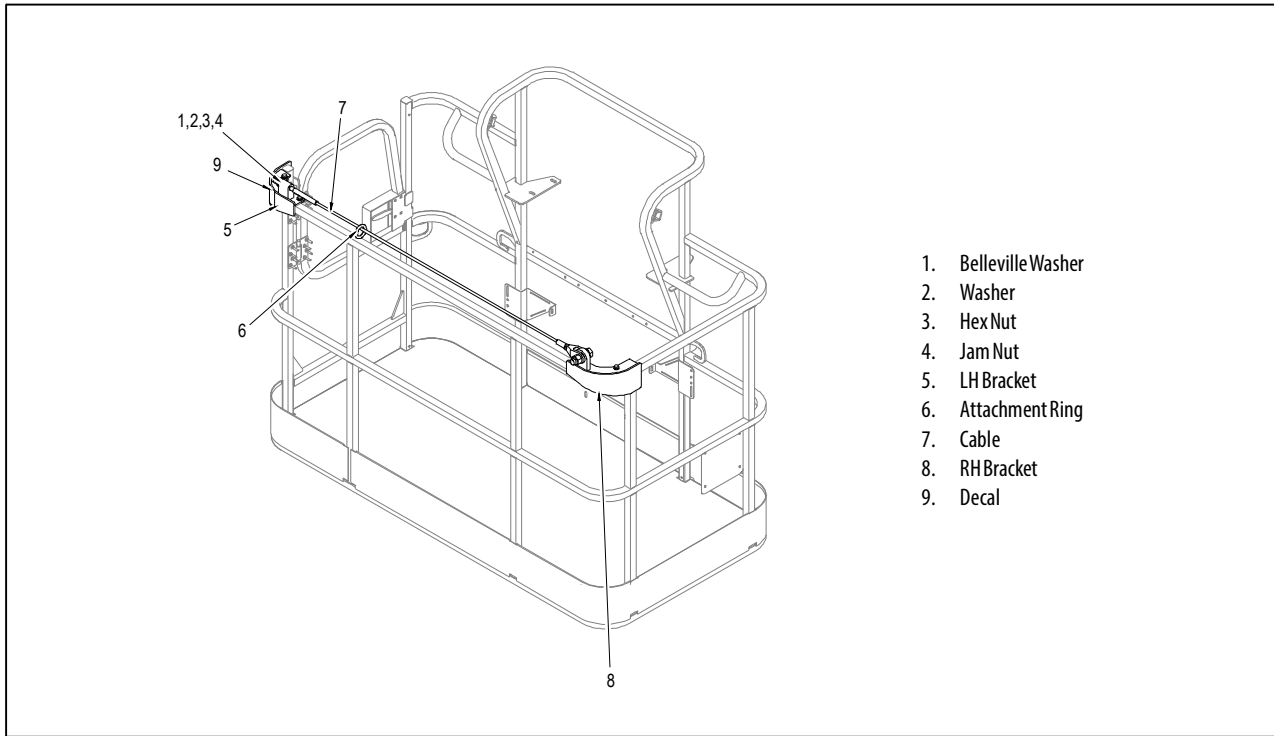

Figure 7-3. Bolt-On External Fall Arrest System

SECTION 8. GENERAL SPECIFICATIONS & OPERATOR MAINTENANCE

8.1 INTRODUCTION

This section of the manual provides additional necessary information to the operator for proper operation and maintenance of this machine.

The maintenance portion of this section is intended as information to assist the machine operator to perform daily maintenance tasks only, and does not replace the more thorough Preventive Maintenance and Inspection Schedule included in the Service and Maintenance Manual.

Other Publications Available:

Service and Maintenance Manual 31215057
 Illustrated Parts Manual 31215058

8.2 OPERATING SPECIFICATIONS AND PERFORMANCE DATA

Operating Specifications

Table 8-1. Operating Specifications

Capacity - ANSI Unrestricted Restricted	600 lb (272kg) 1000 lb (454kg)
Capacity - CE & Australia Unrestricted Restricted	600 lb (270kg) 1000 lb (450kg)
Maximum Operating Slope	5°
Maximum Travel Grade, stowed Position (Gradeability) see Figure 4-4.	40%
Maximum Travel Grade, stowed Position (Side Slope) see Figure 4-5.	5°
Drive Speed	2.8 mph (4.5 km/h)
Drive Speed at Elevation	0.3 mph (0.48 km/h)

SECTION 8 - GENERAL SPECIFICATIONS & OPERATOR MAINTENANCE

Table 8-1. Operating Specifications

Gross Machine Weight - Approximate	56,630 lb (25687 kg)
Weight Distribution: Axles Deployed or Retracted (Front/Rear)	28,881 lb/27,749 lb (13,100 kg/12,587 kg)
Ground Bearing Pressure - Maximum	123 psi (8.65 kg/cm ²)
Maximum Wind Speed	28 mph (12.5 m/s)
Maximum Manual Force	90 lb (400N)
Maximum System Voltage	12 volts
Maximum Main Relief Hyd. Pressure	4600 psi (317 Bar)
Operating Temperature	See Figures 8-1 through 8-2

Dimensional Data

Table 8-2. Dimensional Data

Turning Radius (Axles Retracted) Outside Inside	31 ft. 2.25 in. (9.5 m) 23 ft. 3.75 in. (7.1 m)
Turning Radius (Axles Extended) Inside Outside	7 ft. 6.25 in. (2.3 m) 21 ft. 7.50 in. (6.6 m)
Machine Height (stowed)	10 ft. 2 in. (3.1 m)
Machine Length (stowed)	49 ft. 8 in. (15.1 m)
Machine Length (Transport Position)	39'8" (12.1 m)
Maximum Platform Height	150ft. 0 in. (45.72 m)
Up and Over Height	60ft. 4 in. (18.39 m)
Horizontal Reach from centerline of rotation Unrestricted Capacity Zone Restricted Capacity Zone	85ft. 0 in. (22.86 m) 67ft. 0 in. (20.42 m)
Horizontal Reach over end Unrestricted Capacity Zone Restricted Capacity Zone	65ft. 8 in. (20.01 m) 57ft. 8 in. (17.57 m)

SECTION 8 - GENERAL SPECIFICATIONS & OPERATOR MAINTENANCE

Table 8-2. Dimensional Data

Horizontal Reach over side Unrestricted Capacity Zone	67ft. 10in. (20.67 m)
Restricted Capacity Zone	59ft. 10in. (18.24 m)
Overall Width	
Axles Retracted	8 ft. 1.5 in. (2.5 m)
Axles Extended	16 ft. 6 in. (5.0 m)
Tailswing	2 ft. 5 in. (0.7 m)
Ground Clearance (Axle)	1 ft. 1.5 in. (0.3 m)
Ground Clearance (Chassis)	1 ft. 4 in. (0.4 m)

Capacities

Table 8-3. Capacities

Hydraulic Oil Tank	93 Gal. (352 L)
Fuel Tank	45 Gal. (170 L)
Drive Hub	2.6 quarts (2.5 liters)
Swing Gearbox	3 qt. (2.8 L)

Tires

Table 8-4. Tire Specifications

Type	Directional Lug
Size	445/50D710
Tire Width (Inflated)	16.81" (427mm)
Tire Diameter (Inflated)	46.45" (1180mm)
Load Rating	31000 lb(14,061 kg)

Engine Data

Table 8-5. Engine Data - Deutz TD 3.6L

Type	Turbo-charged Diesel
Number of Cylinders	4
Bore	3.9 in. (98 mm)
Stroke	4.7 in. (120 mm)
Total Displacement	221 cu.in. (3.6 L)
Firing Order	1-3-4-2
Output	99.8 hp (74.4 kW)
Low Idle Engine RPM	1000 ± 50
High Engine RPM	2300 ± 50

Major Component Weights



DO NOT REPLACE ITEMS CRITICAL TO STABILITY WITH ITEMS OF DIFFERENT WEIGHT OR SPECIFICATION (FOR EXAMPLE: BATTERIES, FILLED TIRES, PLATFORM) DO NOT MODIFY UNIT IN ANY WAY TO AFFECT STABILITY.

Table 8-6. Critical Stability Weights

Components	LB	KG
Tire and Wheel Assembly	1193	541
Complete Engine Assembly	1625	737
Drive Hub and Motor	338	153
Swing Drive	225	102
Tower Boom Assembly	12089	5484
Main Boom Assembly (including Jib)	7059	3202
36x96 Platform Assembly	259	117.5

Hydraulic Oil

Table 8-7. Hydraulic Oil

Hydraulic System Operating Temperature Range	S.A.E. Viscosity Grade
+0° to +180°F (-18° to +83° C)	10W
+0° to +210°F (-18° to +99° C)	10W-20, 10W30
+50° to +210°F (+10° to +99° C)	20W-20

NOTE: Hydraulic oils require anti-wear qualities at least API Service Classification GL-3, and sufficient chemical stability for mobile hydraulic system service.

NOTE: Aside from JLG recommendations, it is not advisable to mix oils of different brands or types, as they may not contain the same required additives or be of comparable viscosities.

OIL SAMPLING

This machine is equipped with an oil sampling valve to allow for verification of hydraulic oil condition. Refer to the Service Manual for Oil Sampling procedures.

Table 8-8. Mobilfluid 424 Specs

SAE Grade	10W30
Gravity, API	29.0
Density, Lb/Gal. 60°F	7.35
Pour Point, Max	-46°F (-43°C)
Flash Point, Min.	442°F (228°C)
Viscosity	
Brookfield, cP at -18°C	2700
at 40°C	55 cSt
at 100°C	9.3 cSt
Viscosity Index	152

SECTION 8 - GENERAL SPECIFICATIONS & OPERATOR MAINTENANCE

Table 8-9. Mobil DTE 10 Excel 32 Specs

ISO Viscosity Grade	#32
Specific Gravity	0.877
Pour Point, Max	-40°F (-40°C)
Flash Point, Min.	330°F (166°C)
Viscosity	
at 40°C	33cSt
at 100°C	6.6 cSt
at 100°F	169 SUS
at 210°F	48 SUS
cp at -20°F	6,200
Viscosity Index	140

Table 8-10. UCon Hydrolube HP-5046

Type	Synthetic Biodegradable
Specific Gravity	1.082
Pour Point, Max	-58°F (-50°C)
pH	9.1
Viscosity	
at 0°C (32°F)	340 cSt (1600SUS)
at 40°C (104°F)	46 cSt (215SUS)
at 65°C (150°F)	22 cSt (106SUS)
Viscosity Index	170

SECTION 8 - GENERAL SPECIFICATIONS & OPERATOR MAINTENANCE

Table 8-11. Mobil EAL H 46 Specs

Type	Synthetic Biodegradable
ISO Viscosity Grade	46
Density at 15° C	.874
Pour Point	-49°F (-45°C)
Flash Point	500°F (260°C)
Operating Temp.	-20 to 200°F (-29 to 93°C)
Weight	7.64 lb/gal (0.9 kg/L)
Viscosity	
at 40°C	48.8 cSt
at 100°C	7.8 cSt
Viscosity Index	145

Table 8-12. Mobil EAL 46 Specs

Type	Synthetic Biodegradable
ISO Viscosity Grade	46
Density at 15° C	.93
Pour Point	-27°F (-33°C)
Flash Point	568°F (298°C)
Operating Temp.	-20 to 200°F (-29 to 93°C)
Weight	7.64 lb/gal (0.9 kg/L)
Viscosity	
at 40°C	43.3 cSt
at 100°C	7.7 cSt
Viscosity Index	149

SECTION 8 - GENERAL SPECIFICATIONS & OPERATOR MAINTENANCE

Table 8-13. Exxon Univis HVI 26 Specs

Specific Gravity	32.1
Pour Point	-76°F (-60°C)
Flash Point	217°F (103°C)
Viscosity	
at 40°C	25.8 cSt
at 100°C	9.3 cSt
Viscosity Index	376
NOTE: Mobil/Exxon recommends that this oil be checked on a yearly basis for viscosity.	

Table 8-14. Quintolubric 888-46

Density	0.92 g/cm ³
Pour Point	<-30°C (<-22°F)
Flash Point	300°C (572°F)
Fire Point	360°C (680°F)
Autoignition Temperature	>450°C (842°F)
Viscosity	
at 0°C (32°F)	320 cSt
at 20°C (68°F)	109 cSt
at 40°C (104°F)	47.5 cSt
at 100°C (212°F)	9.5 cSt
Viscosity Index	190

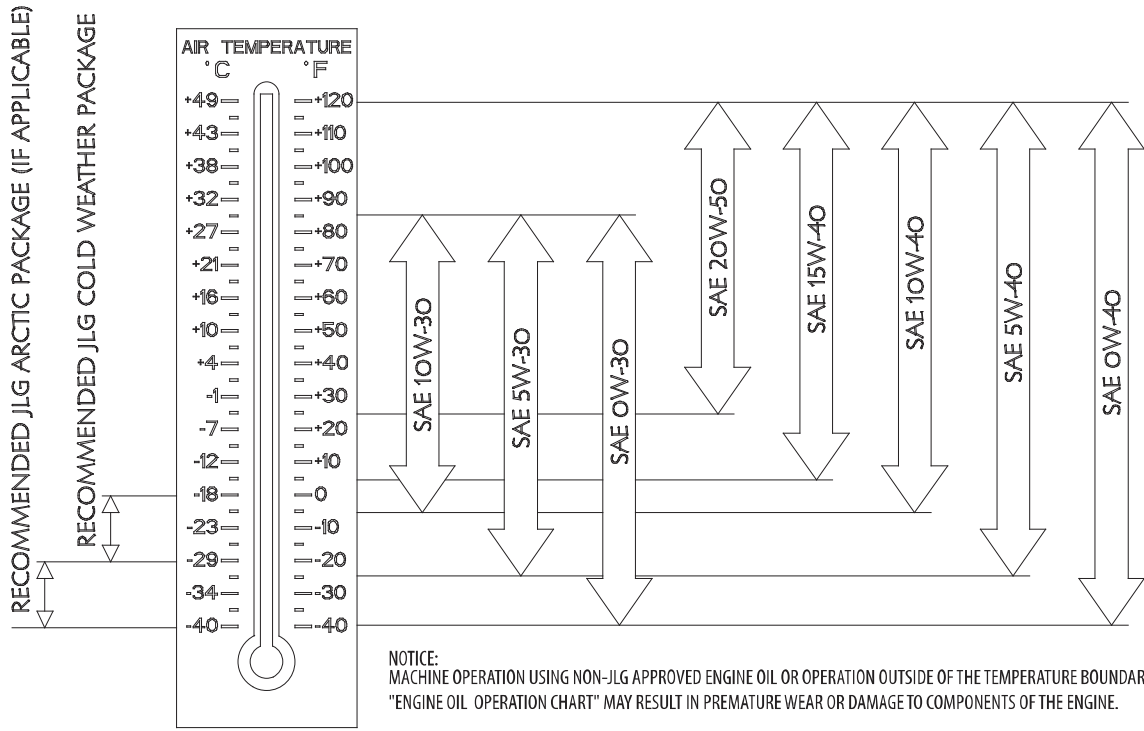

1001159163-A

Figure 8-1. Engine Operating Temperature Specifications

SECTION 8 - GENERAL SPECIFICATIONS & OPERATOR MAINTENANCE

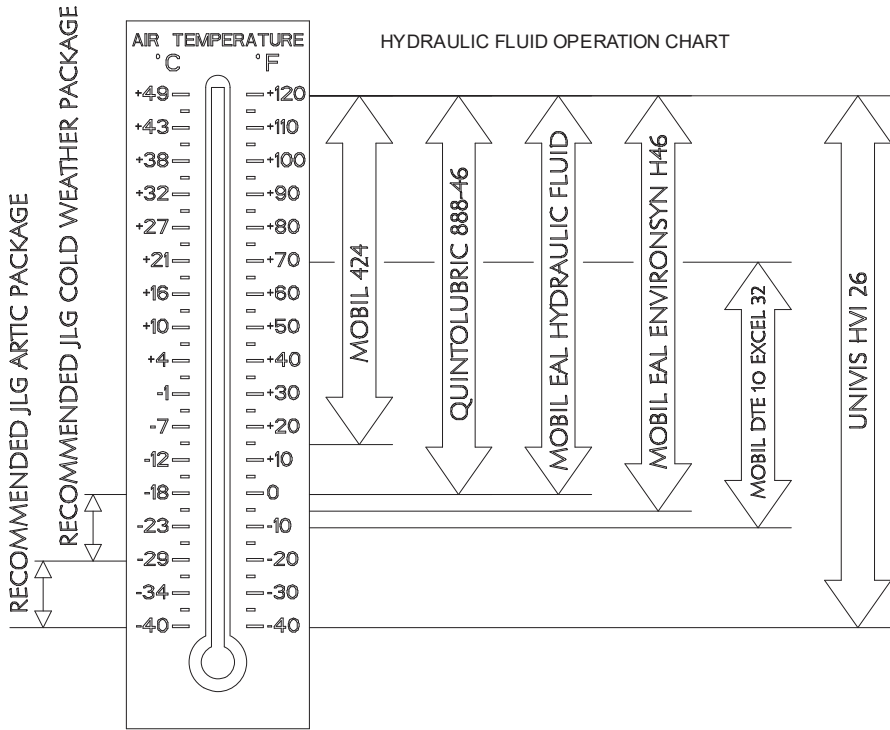

NOTICE:

MACHINE OPERATION USING NON-JLG APPROVED HYDRAULIC FLUIDS OR OPERATION OUTSIDE OF THE TEMPERATURE BOUNDARIES OUTLINED IN THE "HYDRAULIC FLUID OPERATION CHART" MAY RESULT IN PREMATURE WEAR OR DAMAGE TO COMPONENTS OF THE HYDRAULIC SYSTEM.

Figure 8-2. Hydraulic Oil Operation Chart - Sheet 1 of 2

SECTION 8 - GENERAL SPECIFICATIONS & OPERATOR MAINTENANCE

Fluid	Properties		Base				Classifications		
	Viscosity at 40° C (cSt, Typical)	Viscosity Index	Mineral Oils	Vegetable Oils	Synthetic	Synthetic/Polyol Esters	Readily Biodegradable*	Virtually Non-toxic**	Fire Resistant***
Mobilfluid 424	55	145	X						
Mobil DTE 10 Excel 32	32	164	X					X	
Univis HVI 26	26	376	X						
Mobil EAL Hydraulic Oil	47	176		X			X	X	
Mobil EAL EnviroSyn H46	49	145			X		X	X	
Quintolubric 888-46	50	185				X	X	X	X

* Readily biodegradable classification indicates one of the following:

CO2 Conversion > 60% per EPA 560/6-82-003

CO2 Conversion > 80% per CEC-L-33-A-93

** Virtually Non-toxic classification indicates an LC50 > 5000 ppm per OECD 203

*** Fire Resistant classification indicates Factory Mutual Research Corp. (FMRC) Approval

41507-80B

Figure 8-3. Hydraulic Oil Operation Chart - Sheet 2 of 2

SECTION 8 - GENERAL SPECIFICATIONS & OPERATOR MAINTENANCE

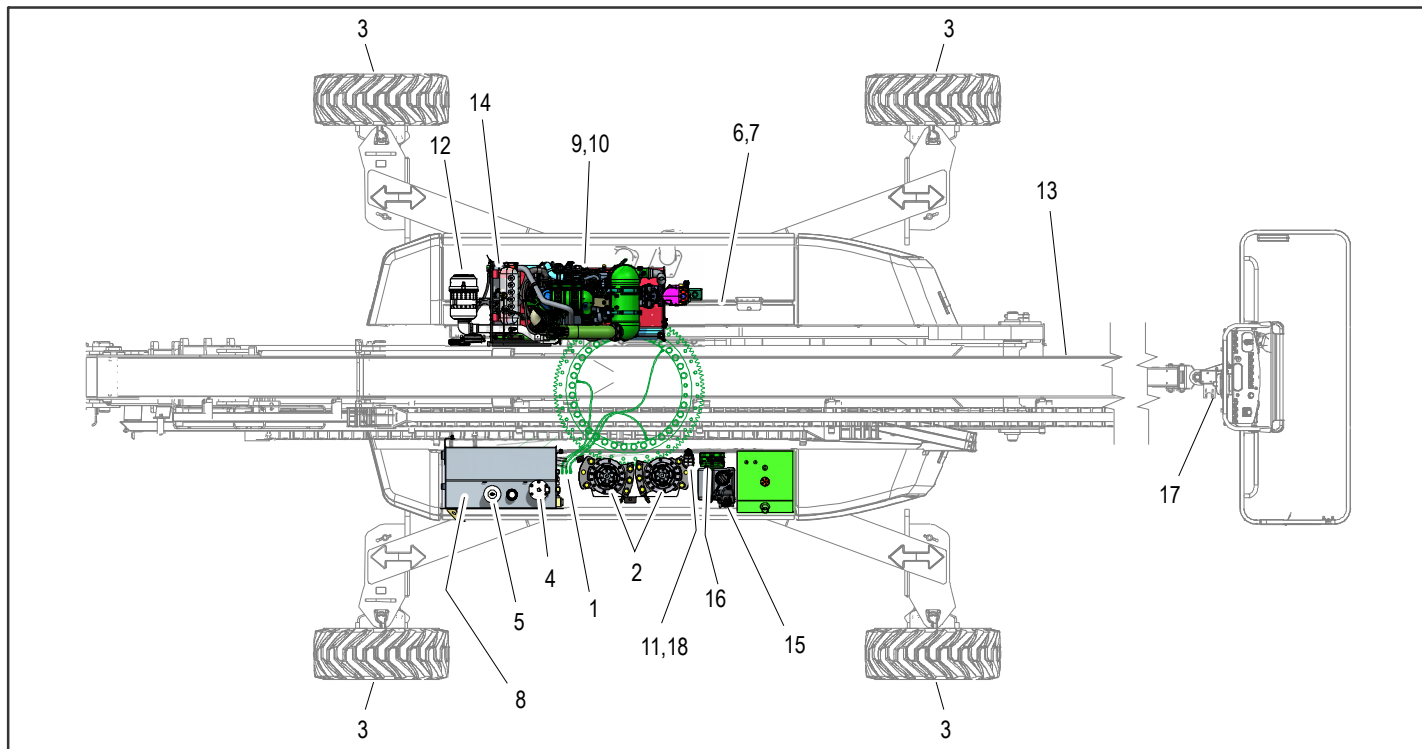

Figure 8-4. Maintenance and Lubrication Diagram

8.3 MAINTENANCE AND LUBRICATION

NOTE: The following numbers correspond to those in Figure 8-4., Maintenance and Lubrication Diagram.

Table 8-15. Lubrication Specifications

KEY	SPECIFICATIONS
MPG	Multipurpose Grease having a minimum dripping point of 350°F (177°C). Excellent water resistance and adhesive qualities, and being of extreme pressure type. (Timken OK 40 pounds minimum.)
EPGL	Extreme Pressure Gear Lube (oil) meeting API service classification GL-5 or MIL-Spec MIL-L-2105
HO	Hydraulic Oil. API service classification GL-3, e.g. Mobilfluid 424
EO	Engine (crankcase) API CJ-4
Super Lube®	Synthetic-Based Oil, Non-Flammable. Withstands temperatures within -45° to 450°F (-43° to 232°C). JLG P/N 3020042.

NOTICE

LUBRICATION INTERVALS ARE BASED ON MACHINE OPERATION UNDER NORMAL CONDITIONS. FOR MACHINES USED IN MULTI-SHIFT OPERATIONS AND/OR EXPOSED TO HOSTILE ENVIRONMENTS OR CONDITIONS, LUBRICATION FREQUENCIES MUST BE INCREASED ACCORDINGLY.

1. Swing Bearing - Remote Lube

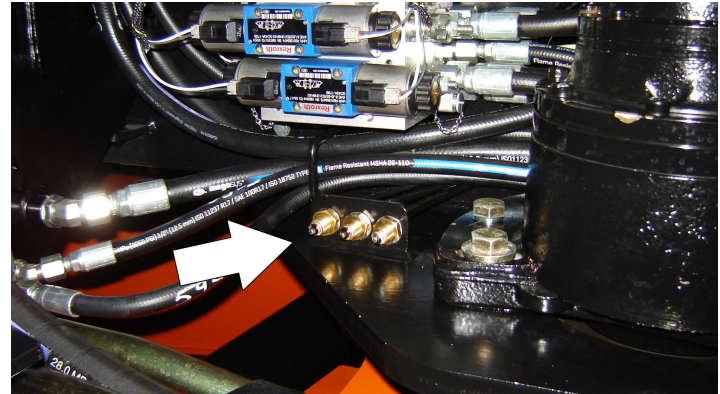

Lube Point(s) - 3 Grease Fitting
 Capacity - A/R
 Lube - MPG
 Interval - Every 3 months or 150 hours of operation
 Comments - Apply grease and rotate in 45 degree intervals until bearing is completely lubricated.

SECTION 8 - GENERAL SPECIFICATIONS & OPERATOR MAINTENANCE

2. Swing Gearbox

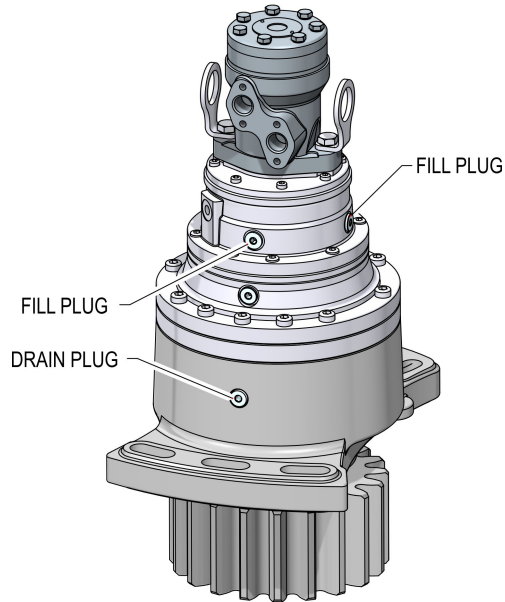

Lube Point(s) - Fill Plug

Capacity - 3 qt. (2.8 L)

Lube - GL-5

Interval - Check level every 150 hrs/Change every 1200 hours of operation. Fill to cover ring gear.

3. Wheel Drive Hub

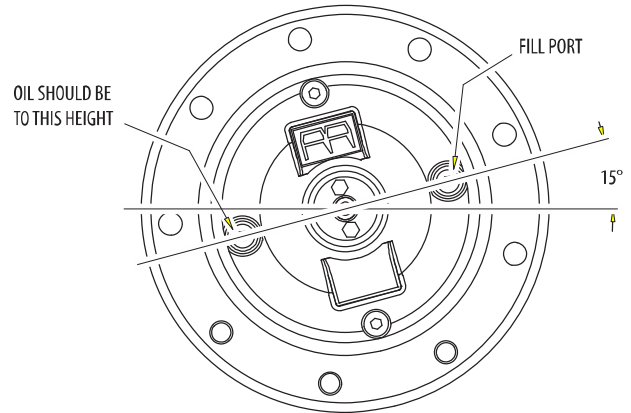

Lube Point(s) - Level/Fill Plug

Capacity - 2.6 quarts (2.5 liters) \pm 10%

Interval - Check level every 3 months or 150 hrs of operation; change every 2 years or 1200 hours of operation

4. Hydraulic Return Filter

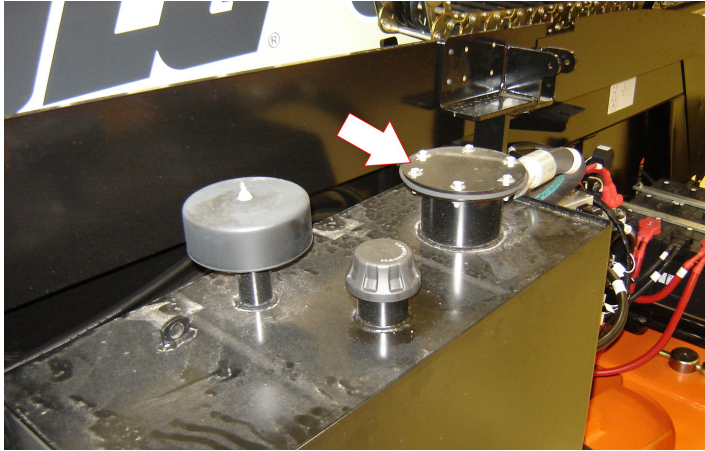

Lube Point(s) - Replaceable Element
Interval - Change after first 50 hours and every 6 months or 300 hours thereafter.

5. Hydraulic Tank Breather

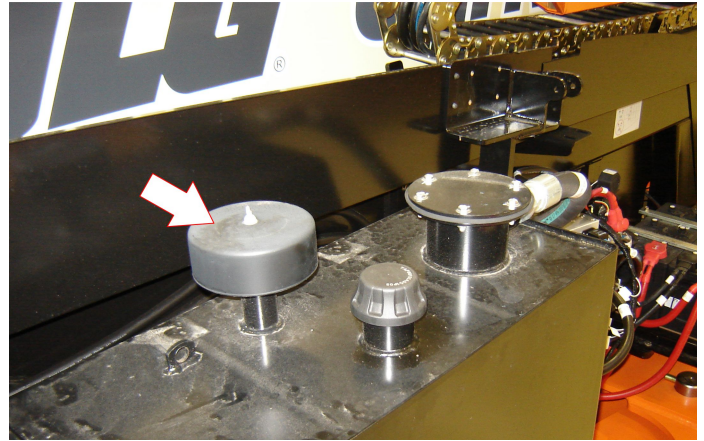

Interval - Change after first 50 hrs. and every 6 months or 300 hrs. thereafter.

Comments - Remove wing nut and cover to replace. Under certain conditions, it may be necessary to replace on a more frequent basis.

SECTION 8 - GENERAL SPECIFICATIONS & OPERATOR MAINTENANCE

6. Hydraulic Charge Filter

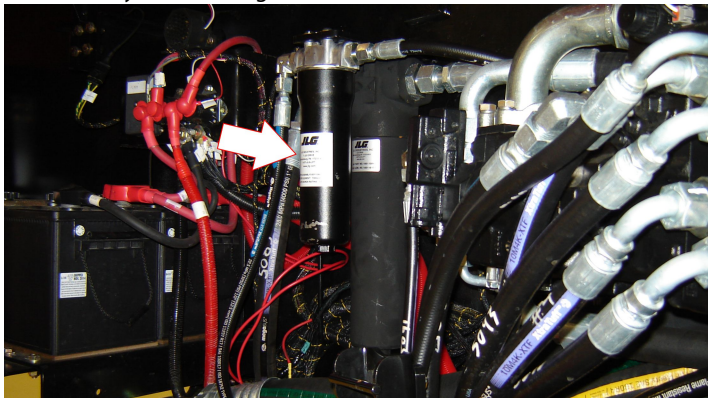

Lube Point(s) - Replaceable Element

Interval - Change after first 50 hours and every 6 months or 300 hours thereafter.

7. High Pressure Filter

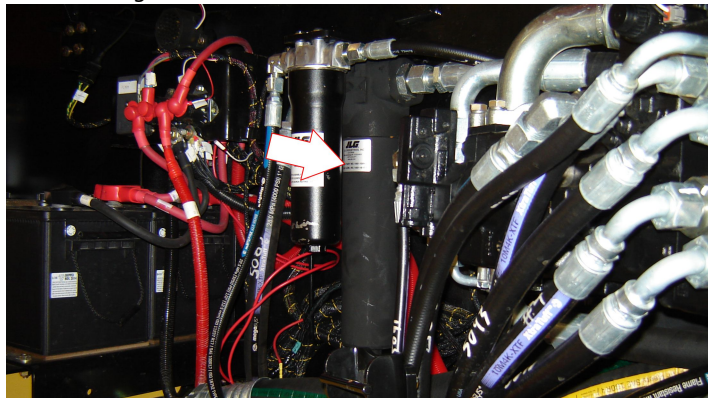

Lube Point(s) - Replaceable Element

Interval - Change after first 50 hours and every 6 months or 300 hours thereafter.

SECTION 8 - GENERAL SPECIFICATIONS & OPERATOR MAINTENANCE

8. Hydraulic Oil

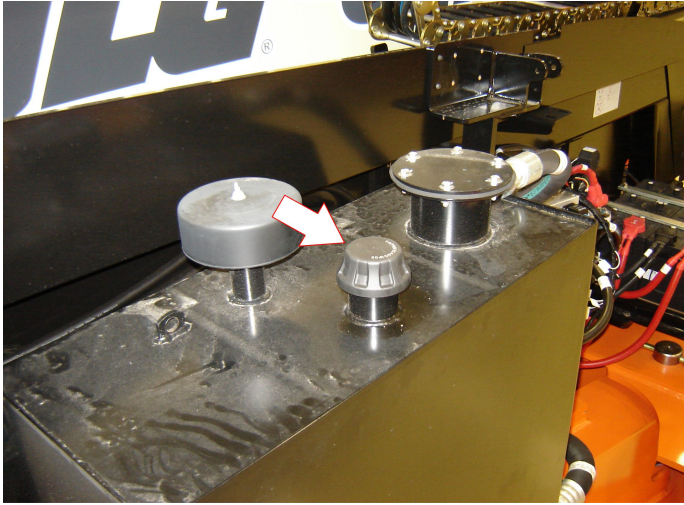

Lube Point(s) - Fill Cap

Capacity - 93 Gallons (352 liters) Tank to Full Mark
124 Gallons (469.3 L) System

Lube - HO

Interval - Check level daily. Change every 2 years or 1200 hours of operation.

9. Oil Change w/Filter - Deutz

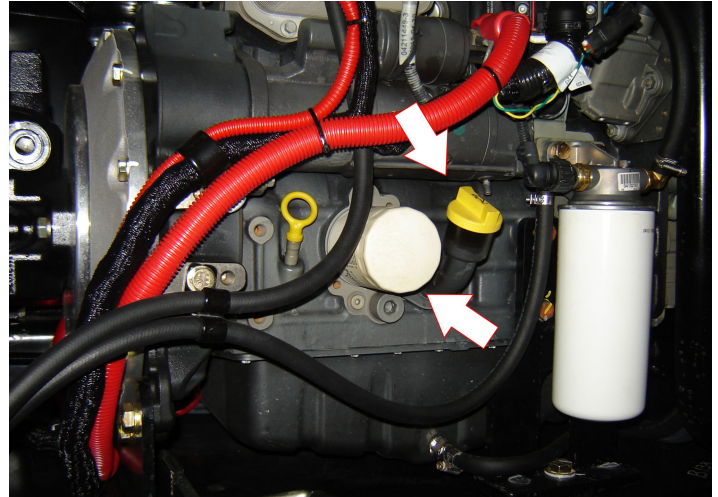

Lube Point(s) - Fill Cap/Spin-on Element

Capacity - 9.4 Quarts (8.9 L)

Lube - EO

Interval - Check level daily; change every 500 hours or yearly, whichever comes first. Adjust final oil level by mark on dipstick.

SECTION 8 - GENERAL SPECIFICATIONS & OPERATOR MAINTENANCE

10. Fuel Filter - Deutz

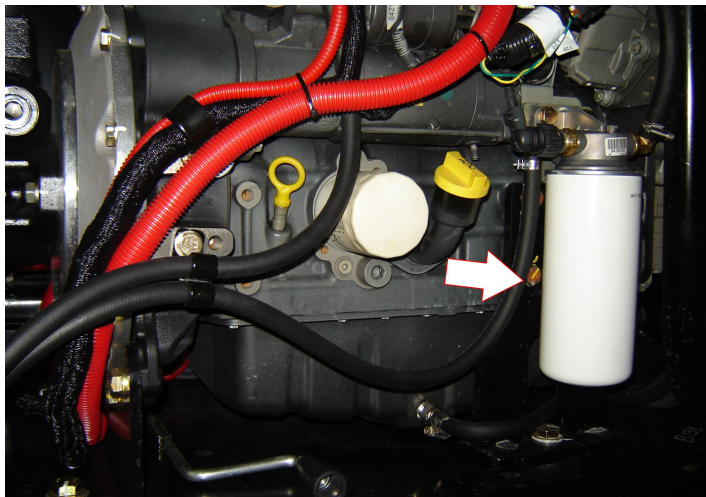

Lube Point(s) - Replaceable Element
Interval - Every year or 500 hours of operation

11. Fuel Pre-Filter

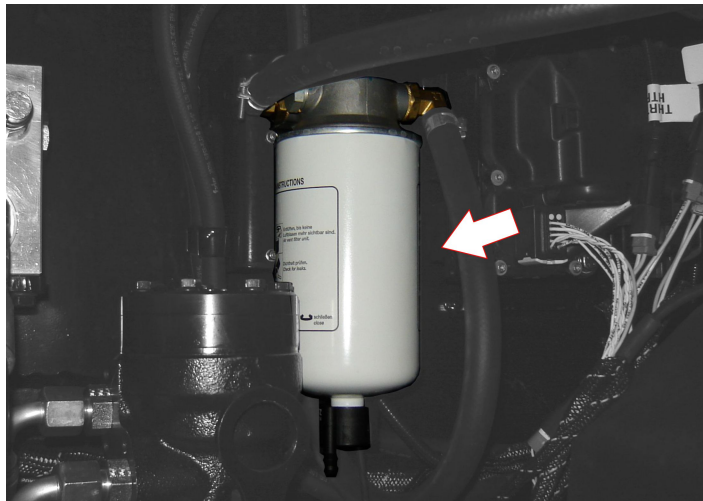

Lube Point(s) - Replaceable Element
Interval - Every year or 500 hours of operation

SECTION 8 - GENERAL SPECIFICATIONS & OPERATOR MAINTENANCE

12. Air Filter

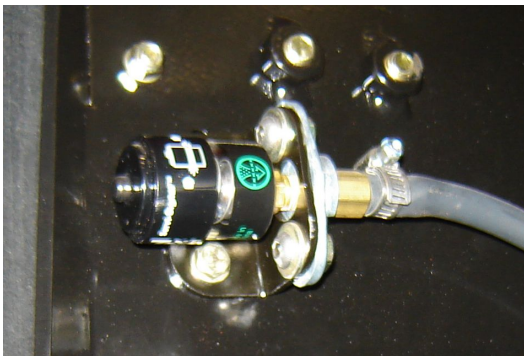

Lube Point(s) - Replaceable Element
Interval - Every 6 months or 300 hours of operation or as indicated by the condition indicator
Comments - Check dust valve for dirt daily

13. Boom

Lube Point(s) - Apply to wear pad contact paths
Lube - Super Lube®
Interval - As needed. Refer to the Service Manual for detailed procedures

14. Radiator

Lube Point(s) - Fill Cap
Lube - Anti-Freeze Coolant (Refer to Engine Manual for compatible coolants)
Capacity - 18.5 qt. (17.5 L)

SECTION 8 - GENERAL SPECIFICATIONS & OPERATOR MAINTENANCE

15. Diesel Exhaust Fluid (DEF) (If Equipped)

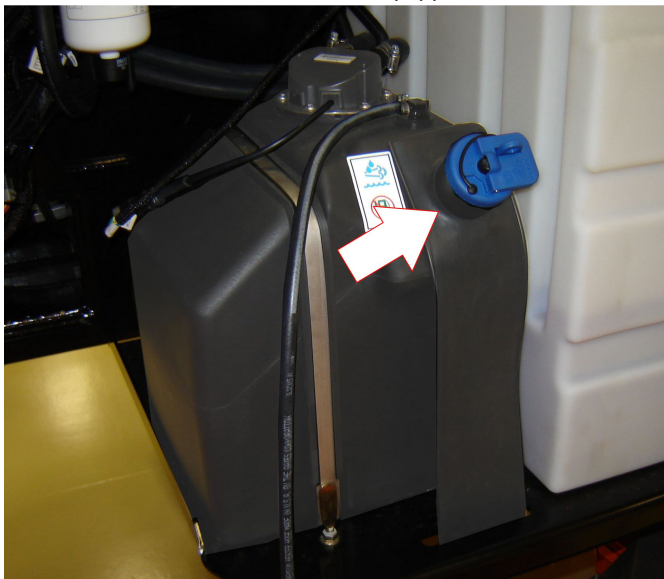

Lube Point - Fill Cap
Lube - DEF
Capacity - 5.7 gal. (21.5 L)

16. DEF Supply Module Filter (If Equipped)

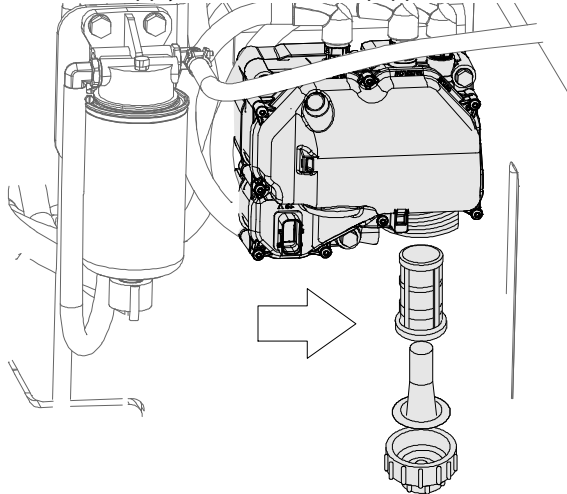

Interval - 500 hours or 2 years, whichever comes first

SECTION 8 - GENERAL SPECIFICATIONS & OPERATOR MAINTENANCE

17. Platform Filter

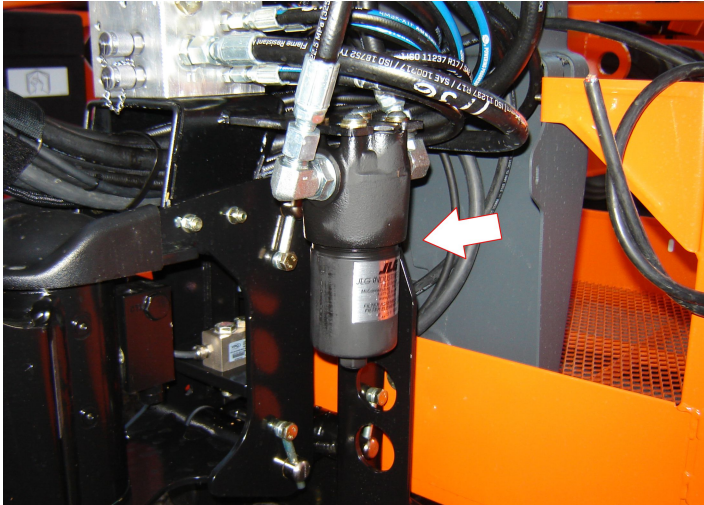

Lube Point - Replaceable Element
Interval - Change after first 50 hours and then every year or 600 hours of operation, whichever comes first

18. Optional Fuel Filter/Water Separator

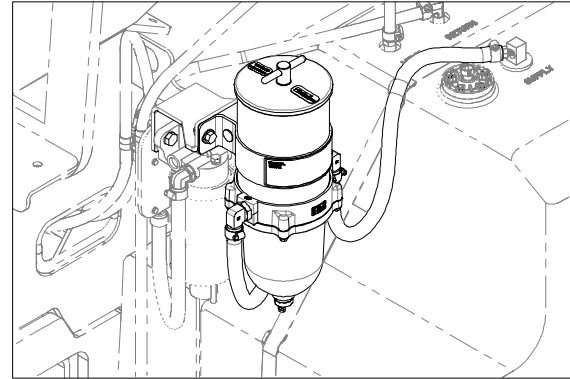

Lube Point(s) - Replaceable Element
Interval - Drain water daily; Change every year or 600 hours of operation

8.4 TIRES & WHEELS

Tire Damage

For polyurethane foam filled tires, JLG Industries, Inc. recommends that when any of the following are discovered, measures must be taken to remove the JLG product from service immediately and arrangements must be made for replacement of the tire or tire assembly.

- a smooth, even cut through the cord plies which exceeds 3 inches (7.5 cm) in total length
- any tears or rips (ragged edges) in the cord plies which exceeds 1 inch (2.5 cm) in any direction
- any punctures which exceed 1 inch in diameter
- any damage to the bead area cords of the tire

If a tire is damaged but is within the above noted criteria, the tire must be inspected on a daily basis to insure the damage has not propagated beyond the allowable criteria.

Tire Replacement

JLG recommends a replacement tire be the same size, ply and brand as originally installed on the machine. Please refer to the JLG Parts Manual for the part number of the approved tires for a particular machine model. If not using a JLG approved replacement tire, we recommend that replacement tires have the following characteristics:

- Equal or greater ply/load rating and size of original
- Tire tread contact width equal or greater than original
- Wheel diameter, width, and offset dimensions equal to the original
- Approved for the application by the tire manufacturer (including inflation pressure and maximum tire load)

Unless specifically approved by JLG Industries Inc. do not replace a foam filled or ballast filled tire assembly with a pneumatic tire. When selecting and installing a replacement tire, ensure that all tires are inflated to the pressure recommended by JLG. Due to size variations between tire brands, both tires on the same axle should be the same.

Wheel Replacement

The rims installed on each product model have been designed for stability requirements which consist of track width, tire pressure, and load capacity. Size changes such as rim width, center piece location, larger or smaller diameter, etc., without written factory recommendations, may result in an unsafe condition regarding stability.

Wheel Installation

It is extremely important to apply and maintain proper wheel mounting torque.

⚠ WARNING

WHEEL BOLTS MUST BE INSTALLED AND MAINTAINED AT THE PROPER TORQUE TO PREVENT LOOSE WHEELS, BROKEN BOLTS, AND POSSIBLE DANGEROUS SEPARATION OF WHEEL FROM THE AXLE. BE SURE TO USE ONLY THE WHEEL BOLTS MATCHED TO THE WHEEL.

Tighten the wheel bolts to the proper torque to prevent wheels from coming loose. Use a torque wrench to tighten the fasteners. If you do not have a torque wrench, tighten the fasteners with a lug wrench, then immediately have a service garage or dealer tighten the wheel bolts to the proper torque. Over-tightening will result in breaking the bolts or permanently deforming the mounting holes in the wheels. The proper procedure for attaching wheels is as follows:

1. Start all wheel bolts by hand to prevent cross threading. DO NOT use a lubricant on threads.
2. Tighten wheel bolts in the following sequence:

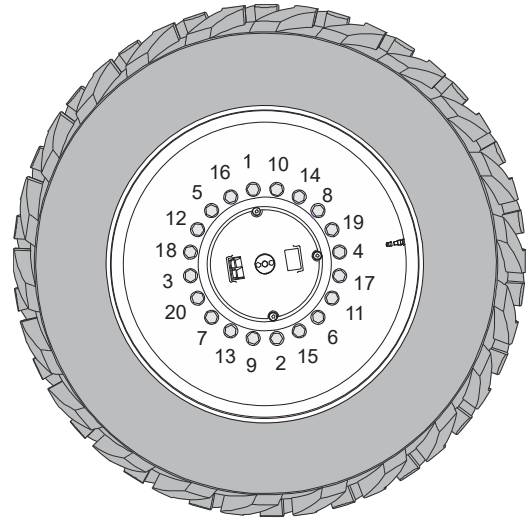

3. The tightening of the wheel bolts should be done in stages. Following the recommended sequence, tighten bolts per wheel torque chart.

Table 8-16. Wheel Torque Chart

TORQUE SEQUENCE		
1st Stage	2nd Stage	3rd Stage
35 ft. lbs. (45 Nm)	80 ft. lbs. (100 Nm)	140 ft. lbs. (185 Nm)

Wheel bolts should be torqued before first road use and after each wheel removal. Check and torque every 3 months or 150 hours of operation.

8.4 SUPPLEMENTAL INFORMATION ONLY APPLICABLE TO CE MACHINES

The following information is provided in accordance with the requirements of the European Machinery Directive 2006/42/EC.

The A-Weighted emission sound pressure level at the work platform is less than 70dB (A).

The guaranteed Sound Power Level (LWA) per European Directive 2000/14/EC (Noise Emission in the Environment by Equipment for Use Outdoors) based on test methods in accordance with Annex III, Part B, Method 1 and 0 of the directive, is 109 dB (A).

The vibration total value to which the hand-arm system is subjected does not exceed $2,5 \text{ m/s}^2$. The highest root mean square value of weighted acceleration to which the whole body is subjected does not exceed $0,5 \text{ m/s}^2$.

EC Declaration of Conformity

Manufacturer:

JLG Industries, Inc.

Address:

1 JLG Drive
1McConnellsburg, PA 17233 USA

Technical File:

JLG EMEA B.V.
Polaris avenue 63,
2132 JH Hoofddorp
The Netherlands

Contact / Position:

Director of Engineering
Europe

Date / Place:

Hoofddorp, Netherlands

Machine Type:

Mobile Elevating Work Platform

Model Type:

1500AJP

Notified Body:

Kuiper Certificering b.v.

EC-Number:

2842

Address:

Van Slingelandtstraat 75, 7331 NM
Apeldoorn, The Netherlands

Certificate Number:

KCEC4447

Reference Standards:

- EN 55011:2009/A1:2010
- EN 61000-6-2:2005
- EN 60204-1:2018
- EN 280:2013+ A1:2015
- EN ISO 12100:2010

JLG Industries Inc. hereby declares that the above mentioned machine conforms with the requirements of:

- 2006/42/EC - Machinery Directive
- 2014/30/EU - EMC Directive
- 2014/53/EU - RED Directive (If fitted with optional equipment)
- 2000/14/EC - Outdoor Noise Directive

NOTE: *This declaration conforms with the requirements of annex II-A of the council directive 2006/42/EC. Any modification to the above described machine violates the validity of this declaration.*

SECTION 8 - GENERAL SPECIFICATIONS & OPERATOR MAINTENANCE



An Oshkosh Corporation Company

Corporate Office

JLG Industries, Inc.

1 JLG Drive

McConnellsburg, PA 17233-9533 USA

☎ (717) 485-5161 (Corporate)

☎ (877) 554-5438 (Customer Support)

☎ (717) 485-6417

Visit our website for JLG Worldwide Locations

www.jlg.com