



OPERATING MANUAL (ANSI/CSA)

# TELEHANDLERS

MODELS **ZB2044**



213530ABA July 2018

**SKYJACK**

## **This manual is based on Serial Numbers:**

ZB 2044 85 800 125 & Above

Please refer to the website - [www.skyjack.com](http://www.skyjack.com) for older Serial Numbers.

### **Skyjack Service Center**

3451 Swenson Ave. St. Charles,  
Illinois, 60174 USA  
Phone: 630-262-0005  
Toll Free: 1-800-275-9522  
Fax: 630-262-0006  
Email: [service@skyjack.com](mailto:service@skyjack.com)

### **Parts (North America)**

Toll Free: 1-800-965-4626  
Toll Free Fax: 1-888-782-4825  
E-mail: [parts@skyjack.com](mailto:parts@skyjack.com)

### **Skyjack Australia Pty Ltd.**

Unit 1, 35 Honeycomb Drive  
Eastern Creek  
New South Wales 2766  
Australia  
Tel: +61 (0) 2 9854 0700  
Fax: +61 (0) 2 9854 0777

### **Parts & Service (Europe)**

Unit 1 Maes Y Clawdd  
Maesbury Road Industrial Estate  
Oswestry, Shropshire SY10 8NN UK  
Phone: +44-1691-676-235  
Fax: +44-1691-676-238  
E-mail: [info@skyjackeurope.co.uk](mailto:info@skyjackeurope.co.uk)

### **Skyjack Brasil**

Alameda Júpiter, 710  
Loteamento American Park Empresarial  
Indaiatuba, SP, Brasil 13347-653  
Tel: +55 19 3936 0132

---

The Safety Alert Symbol identifies important safety messages on telehandlers, safety signs in manuals or elsewhere. When you see this symbol, be alert to the possibility of personal injury or death. Follow the instructions in the safety message.



**This Safety Alert Symbol means attention!**

**Become alert! Your safety is involved.**



**DANGER**

**DANGER** indicates an imminently hazardous situation which, if not avoided, will result in death or serious injury.



**WARNING**

**WARNING** indicates a potentially hazardous situation which, if not avoided, could result in death or serious injury.



**CAUTION**

**CAUTION** indicates a potentially hazardous situation which, if not avoided, may result in minor or moderate injury. It may also be used to alert against unsafe practices.

**IMPORTANT**

**IMPORTANT** indicates a procedure essential for safe operation and which, if not followed, may result in a malfunction or damage to the telehandler.

---

## Table of Contents

### Section 1 - About Your Telehandler

#### Read and Heed

Telehandler Definition .....	7
Purpose of Equipment .....	7
Use of Equipment .....	7
Manual.....	7
Operator .....	7
Service Policy and Warranty .....	7
Optional Accessories .....	7
Scope of this Manual .....	7

#### Safety Rules

Operator Safety Reminders .....	8
Electrocution Hazard .....	9
Safety Precautions .....	10

### Section 2 - Operation

2.1 General .....	17
2.1-1 Operator Qualifications .....	17
2.1-2 Operator's Responsibility for Maintenance .....	17
2.1-3 Maintenance and Inspection Schedule.....	17
2.1-4 Owner's Inspections .....	17
2.2 Major Components.....	18
2.3 Major Assemblies .....	19
2.3-1 Frame .....	19
2.3-2 Cab .....	19
2.3-3 Boom Assembly.....	19
2.3-4 Attachment.....	19
2.4 Serial Number Nameplate.....	19
2.5 Component Identification .....	20
2.5-1 Boom Angle Indicator .....	20
2.5-2 Operator's Cab .....	20
2.5-3 Operator's Cab Controls .....	21
2.6 Component Identification (Special Options).....	25
2.6-1 Main Power Disconnect Switch (If Equipped).....	25
2.6-2 Optional Reserve Steering (If Equipped) .....	25
2.6-3 Optional Secondary Park Brake (If Equipped).....	25
2.6-4 Positive Air Shutoff (If Equipped).....	26
2.7 Operator's Responsibility .....	26
2.8 Visual & Daily Maintenance Inspections .....	27
2.8-1 Labels.....	27
2.8-2 Electrical .....	27
2.8-3 Safety Switches .....	27
2.8-4 Mirrors.....	27
2.8-5 Hydraulic.....	28
2.8-6 Cylinders.....	28
2.8-7 Frame.....	28
2.8-8 Engine Compartment .....	30
2.8-9 Transmission.....	31
2.8-10 Boom .....	32
2.8-11 Lifting Attachment.....	32
2.8-12 Grease Points .....	32
2.8-13 Operator's Cab .....	34

## Section 2 - Operation (Continued)

2.9	Function Tests.....	35
2.9-1	Operator's Cab Controls .....	35
2.10	Start Operation .....	44
2.10-1	Starting the Engine .....	44
2.10-2	Driving the Telehandler.....	45
2.10-3	Driving on Slopes .....	45
2.10-4	Steering the Telehandler.....	46
2.10-5	Leveling the Telehandler.....	46
2.10-6	Raising or Lowering Boom .....	46
2.10-7	Extending or Retracting Boom .....	47
2.10-8	Handling Loads .....	47
2.10-9	Parking and Shutting-down the Telehandler .....	48
2.11	Refueling Procedure (Diesel Fuel Only).....	48
2.12	Use of the Capacity Charts .....	50
2.12-1	Examples on Reading the Capacity Chart .....	51
2.13	Attachments Installation .....	52
2.13-1	Removing Attachments Using the Quick Attach Feature.....	52
2.13-2	Installing Attachments Using the Quick Attach Feature.....	52
2.14	Handling Loads .....	53
2.14-1	Handling Loads at Ground Level .....	53
2.14-2	Handling Loads at Variable Heights.....	54
2.14-3	Adjusting Forks.....	55
2.14-4	Changing Forks .....	55
2.14-5	Slinging Loads.....	55
2.15	Optional Attachments.....	56
2.15-1	Fork Positioner Attachment .....	56
2.15-2	Combination Fork Positioner/Sideshift Attachment .....	56
2.15-3	Bridge Stripper Attachment.....	57
2.15-4	Pipe and Pole Grapppler .....	57
2.15-5	Pipe and Pole Handler.....	58
2.15-6	Hydraulic Winch.....	58
2.15-7	Jib Boom Attachment (5-ft) .....	59
2.15-8	Light-material Bucket.....	59
2.15-9	Coil Boom .....	60
2.15-10	Third-party Attachments and Platform for Elevating Personnel.....	62
2.16	Loading and Transporting .....	63
2.16-1	Loading and Tie-down.....	63
2.16-2	Towing the Telehandler.....	64
2.17	Coolant Level Maintenance.....	65
2.17-1	Radiator Fill Maintenance.....	65
2.18	Tables .....	66
2.19	Labels.....	72

### List of Tables

Table 2.1	Standard and Optional Equipment .....	66
Table 2.2	Specifications and Features.....	67
Table 2.3	Tire/Wheel Specifications.....	68
Table 2.4	Recommended Fluids/Lubrication.....	69
Table 2.5	Maintenance and Inspection Schedule .....	70
Table 2.6	Operator's Checklist.....	71



**SKYJACK** is continuously improving and expanding product features on its equipment, therefore, specifications and dimensions are subject to change without notice.

### Telehandler Definition

A material handler designed primarily as a fork truck with a pivoting telescopic boom which enables it to pick and place loads at distances as well as various lift heights.

### Purpose of Equipment

The SKYJACK telehandlers are designed to lift, handle and transport agricultural or industrial products by means of specific attachments.

### Use of Equipment

The telehandler is a highly maneuverable, mobile work station. Lifting, handling and driving must be on a flat, level, compacted surface. It can be driven over uneven terrain only when the boom is fully lowered.

### Manual

The operating manual is considered a fundamental part of the telehandler. It is a very important way to communicate necessary safety information to users and operators. A complete and legible copy of this manual must be kept in the provided weather-resistant storage compartment on the telehandler at all times.

### Operator

The operator must read and completely understand both this operating manual and the safety panel label located on the telehandler and all other warnings in this manual and on the telehandler. Compare the labels on the telehandler with the labels found within this manual. If any labels are damaged or missing, replace them immediately.

### Service Policy and Warranty

SKYJACK warrants each new ZB series telehandler to be free of defective parts and workmanship for the first 12 months or 2000 hours, whichever occurs first. Any defective part will be replaced or repaired by your local SKYJACK dealer at no charge for parts or labor. Contact SKYJACK Service Department for warranty statement extensions or exclusions.

### Optional Accessories

The SKYJACK telehandler is designed to accept a variety of optional accessories. These are listed under “Optional Attachments” in [Section 2](#). Operating instructions for these options (if equipped) are located in [Section 2](#) of this manual.

For non-standard components or systems, contact the SKYJACK Service Department at

 : 800 275-9522

 : 630 262-0006

Include the model and serial number for each applicable telehandler.

### Scope of this Manual

a. **This manual applies** to the ANSI/ASME/ITSDF and CSA versions of the ZB2044 telehandler.

- **Equipment identified** with “ANSI” meets the ANSI/ITSDF B56.6-2016 standard.
- **Equipment identified** with “CSA” meets the CSA B335-04 standard.

b. **CSA (Canada)**

Operators are required to conform to national, territorial/provincial and local health and safety regulations applicable to the operation of this telehandler.

c. **ANSI (United States)**

Operators are required by the current ANSI standards to conform to national, territorial/provincial and local health and safety regulations applicable to the operation of this telehandler.

**WARNING**

**Failure to comply with your required responsibilities in the use and operation of the telehandler could result in death or serious injury!**

**Operator Safety Reminders**

A study conducted by St. Paul Travelers showed that most accidents are caused by the failure of the operator to follow simple and fundamental safety rules and precautions.

You, as a careful operator, are the best insurance against an accident. Therefore, proper usage of this telehandler is mandatory. The following pages of this manual should be read and understood completely before operating the telehandler.

Common sense dictates the use of protective clothing when working on or near machinery. Use appropriate safety devices to protect your eyes, ears, hands, feet and body.

Some attachments may not be approved for use with certain telehandler models. Use only approved attachments.

Any modifications from the original design are strictly forbidden without written permission from Skyjack.



**Electrocution Hazard**

**This telehandler is not electrically insulated.** Use extreme caution around high-voltage overhead power lines and maintain a Minimum Safe Approach Distance (MSAD) of 10 feet from source of power. Adhere to all federal/national, state/provincial, or local safety regulations for your own protection.

No part of telehandler or payload should be brought closer to any energized overhead electrical conductor with nominal phase voltage rating as specified below:

Voltage	Distance
750 to 150,000	10 feet
150,000 to 250,000	15 feet
250,000	20 feet

**DANGER**

**Never approach any power line with any part of telehandler. Use extreme caution; serious injury or death can result with contact from any power line.**

**IMPORTANT**

**Always assume electrical power sources and overhead lines are energized.**

**DO NOT USE TELEHANDLER AS A GROUND FOR WELDING.  
DO NOT OPERATE TELEHANDLER DURING LIGHTNING OR STORMS.**



**Safety Precautions**

Know and understand all safety precautions before going on to the next section.



**WARNING**

**DO NOT** operate this telehandler without proper authorization and training. Failure to avoid this hazard could result in death or serious injury.



**WARNING**

Failure to heed the following safety precautions could result in tip over, falling, crushing, or other hazards leading to death or serious injury.

- **MAKE SURE** all DANGER, WARNING, CAUTION and INSTRUCTIONAL DECALS are in place and can be read. Clean or replace decals as required.
- **KNOW** all national, state/provincial and local rules which apply to your telehandler and jobsite.
- **WEAR** all the protective clothing and personal safety devices issued to you or called for by job conditions.

- **DO NOT** use telehandler as a man lift or equip this telehandler with a personnel work platform.



- **DO NOT** use carriage or any other portion of the boom for slinging loads



- **DO NOT** elevate the boom in windy or gusty conditions.



- **DO NOT** wear loose clothing, dangling neckties, scarves, rings, wristwatches or other jewelry while operating this telehandler.



- **DO NOT** drive with boom elevated.



- **DO NOT** climb on this vehicle for any reason.



- **DO NOT** operate on surfaces not capable of holding the weight of the telehandler; including the rated load (e.g., covers, drains, and trenches).



- **DO NOT** stand on forks. Failure to heed could result in death or serious injury.



- **DO NOT** maneuver a load while moving. This greatly increases the chance of spills and injury.



**Safety Precautions (Continued)**

Know and understand all safety precautions before going on to the next section.

- **DO NOT** exceed the maximum safe operating slope.

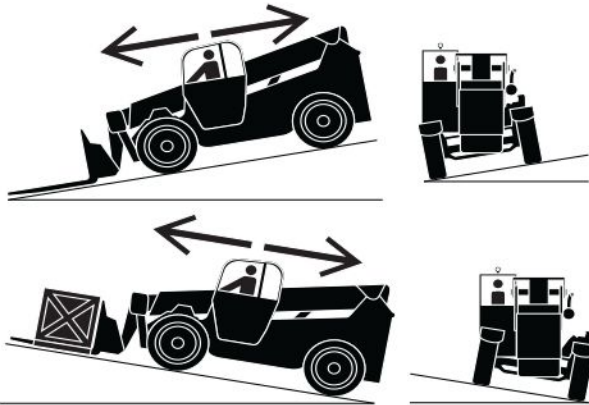

- **DO NOT** lower the boom unless the area below is clear of personnel and obstruction.



- **DO NOT** elevate the boom while the telehandler is on a truck, forklift or other device or vehicle.



- **DO NOT** use frame leveling when boom is elevated. It is recommended that frame leveling be used only when boom is retracted and in the lowered position.



- **ENSURE** that there are no personnel or obstructions in the path of travel, including blind spots.



- **BE AWARE** of blind spots when operating the telehandler.

- **DO NOT** use the frame leveling mechanism to compensate for swinging loads.



- **ALWAYS** Keep head, arms, hands, legs and all other body parts inside the operator's cab.



- **DO NOT** enter the danger area under or around the boom when forks are off the ground or while engine is running.

- **AVOID** jerks and sudden stops.



- **AVOID** entanglement with ropes, cords or hoses.



**Safety Precautions (Continued)**

Know and understand all safety precautions before going on to the next section.

- **BE AWARE** of all obstructions while traveling. Check for clearance before traveling between obstacles.

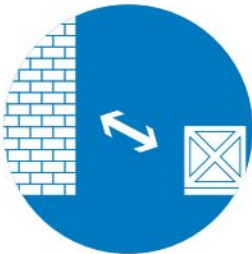

- **USE CAUTION** when boom is fully extended. The further out the boom is extended, the less load telehandler can support.



- **USE CAUTION** when placing loads at high elevations and on downhill slopes.



- **WALK AROUND** the telehandler before operation and check for any visible signs of damage or malfunction.

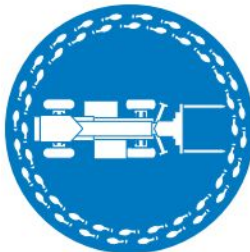

- **ALWAYS** maintain three points of contact when entering vehicle. Use provided hand-holds and steps only.



- **ALWAYS** wear your seat belt when operating this vehicle.



- **KNOW** the weight of the load you are transporting. Never lift more than the lifting capacity at any given extension or elevation of the boom as listed on the capacity charts.



- **CHECK** for cracks and signs of stress.



- **TRAVEL SLOWLY** over rough terrain.



- **If operation in areas with holes or dropoffs is absolutely necessary**, ensure that all 4 wheels or outriggers (if equipped) have contact with firm surface. Then level the frame. Once frame is level the boom can be elevated. After elevation, the drive function must not be activated.



- **DRIVE DOWNHILL UNLOADED.** Without a load, the back end is the heaviest part of the telehandler. Driving downhill decreases potential for tipover.



**Safety Precautions (Continued)**

Know and understand all safety precautions before going on to the next section.

- **DRIVE UPHILL LOADED.** When holding a load, driving uphill decreases potential for load to slip out.



- **TETHER LOADS** that may swing, keeping them close to the ground. Provide ample clearance for personnel to guide the load safely.



- **ALWAYS LEVEL FRAME** before elevating the boom



- **SLINGING LOADS** is acceptable only when the load is appropriately attached to a jib boom or the throat of a tilted fork, and the precautions outlined in [Section 2.12](#) are followed.



- **WHEN TRANSPORTING LOADS** fully retract the boom, keep the load low to the ground and forks tilted back slightly. This is the most stable position possible for the vehicle.



- **BE AWARE** of the telehandler's travel envelope, especially when turning. Keep sufficient clearance at all times between the telehandler and any obstacles or people.



- **KEEP** forks close to the ground when in motion to increase telehandler stability and decrease potential for injury to others. When fully stopped, lower forks completely to the ground.

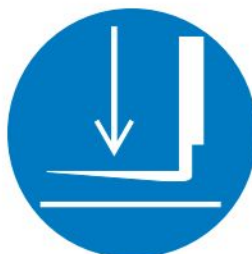

- **KEEP OTHERS AWAY** at all times during operation.



- **TILT** forks backwards slightly when traveling to decrease potential of load slipping off.



- **CHECK** lights (if equipped) for proper function before operating.



- **SECURE** loose loads with chains or straps to decrease potential of spills or injury to others.

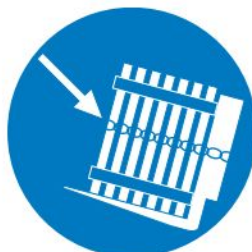

- **ENSURE ALL** tires are in good condition and lug nuts are properly tightened.



**Safety Precautions (Continued)**

Know and understand all safety precautions before going on to the next section.

- **DO NOT** alter or disable safety devices.
- **DO NOT** burn or drill holes in forks. Modifying any part of telehandler or attachment affects its capacity and/or stability.
- **DO NOT** try to start the telehandler by pushing or towing. Such operation may cause severe damage to the transmission - [Refer to Section 2.](#)
- **IF DRIVING ON ROADS OPEN TO PUBLIC TRAFFIC** respect the local regulations.
- **THE OPERATOR'S CAB** provides a falling object protection structure (FOPS) and a rollover protection structure (ROPS). **Do not make any modification to this structure.** If damaged, the cab cannot be repaired. It must be replaced.
- **STUNT** driving and horseplay are prohibited.
- **ALWAYS USE FRONT** steering when traveling at high speeds; i.e., on highways or public roads.
- **DO NOT** change steering mode while the telehandler is traveling. Change the steering mode only when telehandler is stopped, and wheels aligned straight ahead.
- **ALWAYS** look in the direction of travel. Reduce speed and be careful especially when traveling in reverse and/or turning. Bring the telehandler to a complete stop before changing the direction of travel.
- **STAY CLEAR** of pinch points and rotating parts on the material handler. Getting caught in a pinch point or a moving part can cause serious injury or death. Before performing any maintenance on telehandler, follow the shutdown procedure in [Section 2.10-9.](#)
- **DO NOT** position the telehandler against another object to steady the load.
- **SHUT DOWN** by positioning the telehandler in a safe location. Lower forks to ground, apply the parking brake, move all controls to 'neutral' and allow engine to run at low idle for 3 to 5 minutes after a full load operation. Stop engine and remove ignition key to prevent unauthorized use. Block tires.

**WARNING**

**Always engage park brake and shut off engine before leaving the operator's cab.**

**Safety Precautions (Continued)**

Know and understand all safety precautions before going on to the next section.

**WARNING**

**Entering and exiting the telehandler should only be done using the three points of contact.**

- Use only equipped access openings.
- Enter and exit only when the telehandler is in the fully retracted position.
- Do use three points of contact to enter and exit the cab.
- Three points of contact means that two hands and one foot or one hand and two feet are in contact with the telehandler or the ground at all times during entering and exiting.

**WARNING**

**Operator should not use any telehandler that:**

- does not appear to be working properly.
- has been damaged or appears to have worn or missing parts.
- has alterations or modifications not approved by the manufacturer.
- has safety devices which have been altered or disabled.
- has been tagged or locked out for non-use or repair.
- bears an unapproved attachment.

**Failure to avoid these hazards could result in death or serious injury.**

**Jobsite Inspection**

- Do not use in hazardous locations (see NFPA 505).
- Perform a thorough jobsite inspection prior to operating the telehandler, to identify potential hazards in your work area.
- Be aware of moving equipment in the area. Take appropriate actions to avoid collision.





## 2.0 Operation

This section provides the necessary information needed to operate the telehandler. It is important that the user reads and understands this section before operating the telehandler.

### 2.1 General

In order for this telehandler to be in good working condition, it is important that the operator meets the necessary qualifications and follows the maintenance and inspection schedule referred to in this section.

#### 2.1-1 Operator Qualifications

- Only trained and authorized personnel shall be permitted to operate the telehandler.
- Safe use of this telehandler requires the operator to understand the limitations and warnings, operating procedures and operator's responsibility for maintenance. Accordingly, the operator must understand and be familiar with this operating manual, its warnings and instructions, and all warnings and instructions on the telehandler.
- The operator must be familiar with employer's work rules and related government regulations and be able to demonstrate the ability to understand and operate this make and model of telehandler in the presence of a qualified person.



#### **WARNING**

**DO NOT operate this telehandler without proper authorization and training. Failure to avoid this hazard could result in death or serious injury.**

#### 2.1-2 Operator's Responsibility for Maintenance



#### **WARNING**

**Maintenance must be performed by trained and competent personnel who are familiar with mechanical procedures.**

**Death or serious injury could result from the use of a telehandler that is not properly maintained or kept in good working condition.**

- The operator must be sure that the telehandler has been properly maintained and inspected before using it.
- The operator must perform all the daily inspections and function tests found in [Table 2.5](#), even if the operator is not directly responsible for the maintenance of this telehandler.

#### 2.1-3 Maintenance and Inspection Schedule

- The inspection points covered in [Table 2.5](#) indicate the areas of the telehandler to be maintained or inspected and at what intervals the maintenance and inspections are to be performed.
- The actual operating environment of the telehandler may affect the maintenance schedule.



#### **WARNING**

**Use original or manufacturer-approved parts and components for the telehandler.**

#### 2.1-4 Owner's Inspections

It is the responsibility of the owner and/or operator to arrange daily, quarterly (or 250 hours) and annual inspections of the telehandler. Refer to [Table 2.5](#) for recommended maintenance and inspection areas and intervals.

2.2 Major Components

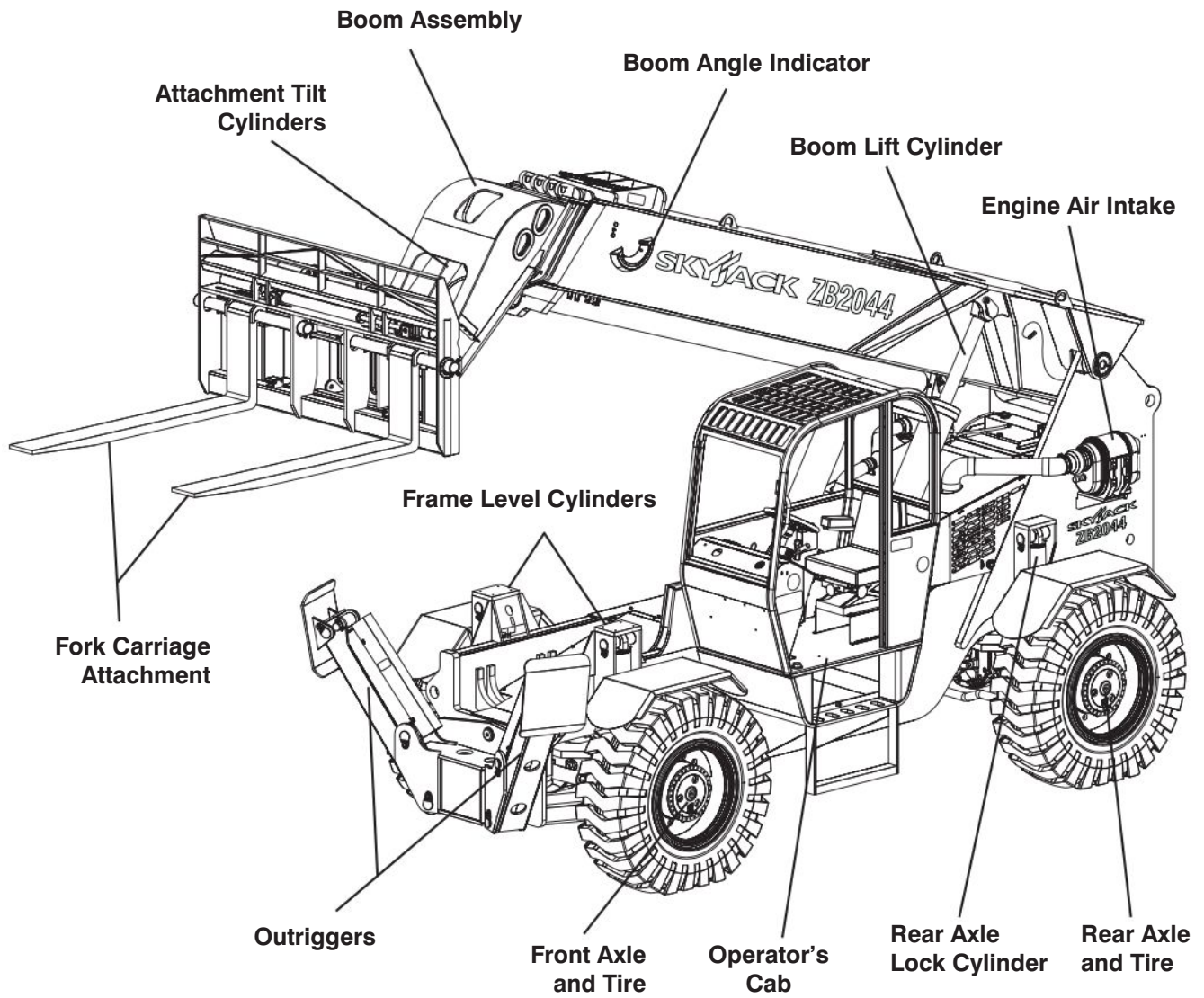

# ZB2044 Telehandler

### 2.3 Major Assemblies

The telehandler consists of four major assemblies: the frame, boom assembly, attachment and cab.

#### 2.3-1 Frame

The frame is a one-piece weldment that supports the boom assembly. The parking brake is a pinion-mounted disc brake on the front axle. ZB2044 model is equipped with a dual service brake system.

#### 2.3-2 Cab

The cab is the safety structure enclosing the operator. It also furnishes the controls of the telehandler.

#### 2.3-3 Boom Assembly

The boom is mounted on the frame and supported by lift cylinders on each side of the frame. The boom assembly consists of main boom section and primary boom section, as well as a third boom section.

Boom assembly also includes a subcarriage which is mounted to the yoke and is supported by two tilt cylinders.

#### 2.3-4 Attachment

The attachment is a material-handling device attached to the boom. The standard attachment is a fork carriage attachment. The standard carriage is available in 60", 72" and 84" widths. Optional attachments include combination fork positioner/sideshift attachment, fork positioner, pipe and pole clamp and grapple, coil boom, bridge stripper, light material bucket, jib boom, & winch attachment. Refer to [Section 2.15](#) for optional attachments.

### 2.4 Serial Number Nameplate

The serial number nameplate is located inside the operator's cab and lists the following:

- Model number
- Serial number
- Maximum capacity
- Maximum lift height
- Maximum machine weight without attachment
- Original supplied attachments
- Year of manufacture
- Voltage

**2.5 Component Identification**

The following descriptions are for identification, explanation and locating purposes only.

**2.5-1 Boom Angle Indicator**

The boom angle indicator is a quick reference for the operator to determine the boom's angle of elevation in reference to the horizontal.

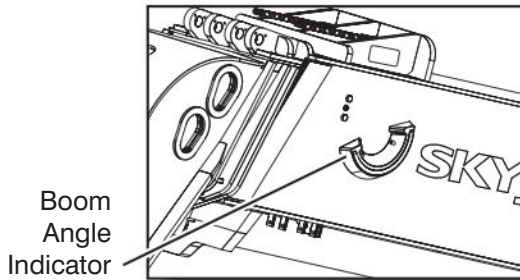

Figure 2-1 Boom Angle Indicator

The angle indicator has degree numbers from -20° to +80°. The numbers should be visible to operator at all times. Capacities listed in capacity flip charts are based on and vary with the boom angle of telehandler.

**2.5-2 Operator's Cab**

The operator's cab allows vision from all sides and is equipped with a rollover and falling object protective structure.



**WARNING**

**The operator's cab provides a falling object protection structure (FOPS) and a rollover protection structure (ROPS). Do not make any modification to this structure. If damaged, the cab cannot be repaired. It must be replaced.**

A fully-enclosed cab with windows and door is available as an option. Included in this option is the windshield wiper, interior light and air heater/defroster. Air conditioner is also available as an option for fully enclosed cab.

The operator's seat is equipped with a seat belt. Use this seat belt at all times when operating the telehandler.

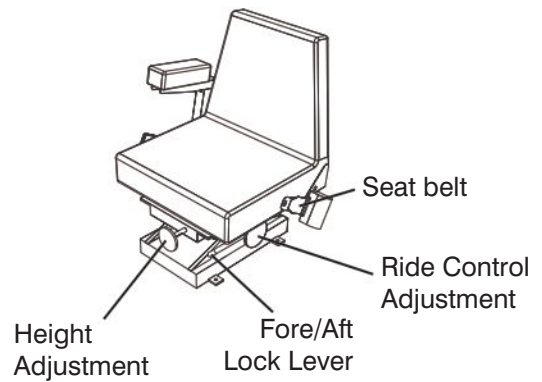

Figure 2-2 Telehandler Seat

**Seat**

The telehandler seat is equipped with devices which allow for the adjustment of seat height and distance from the controls. Adjust the seat so that foot pedals, steering wheel and instrument panel controls are within easy reach of the operator.

The height adjustment is located on the front side of the seat and is operated by turning the rotary knob. Clockwise rotation lowers the seat, counter clockwise raises the seat.

The ride control is located on the left of the seat and is also operated by means of a rotary knob. Clockwise rotation decreases the firmness while counterclockwise rotation increases the firmness.

The fore and aft lock lever is located on the front-left corner of the seat. Pushing the lever to the left unlocks the seat, allowing fore and aft adjustment.



**WARNING**

**The seat belt must be worn at all times.**

**Manual Storage Box**

This weather-resistant box is mounted at the back of the operator's seat. It contains operating manual and other important documentation. The operating manual for this make and model of telehandler must remain with the telehandler and should be stored in this box.



## 2.5-3 Operator's Cab Controls

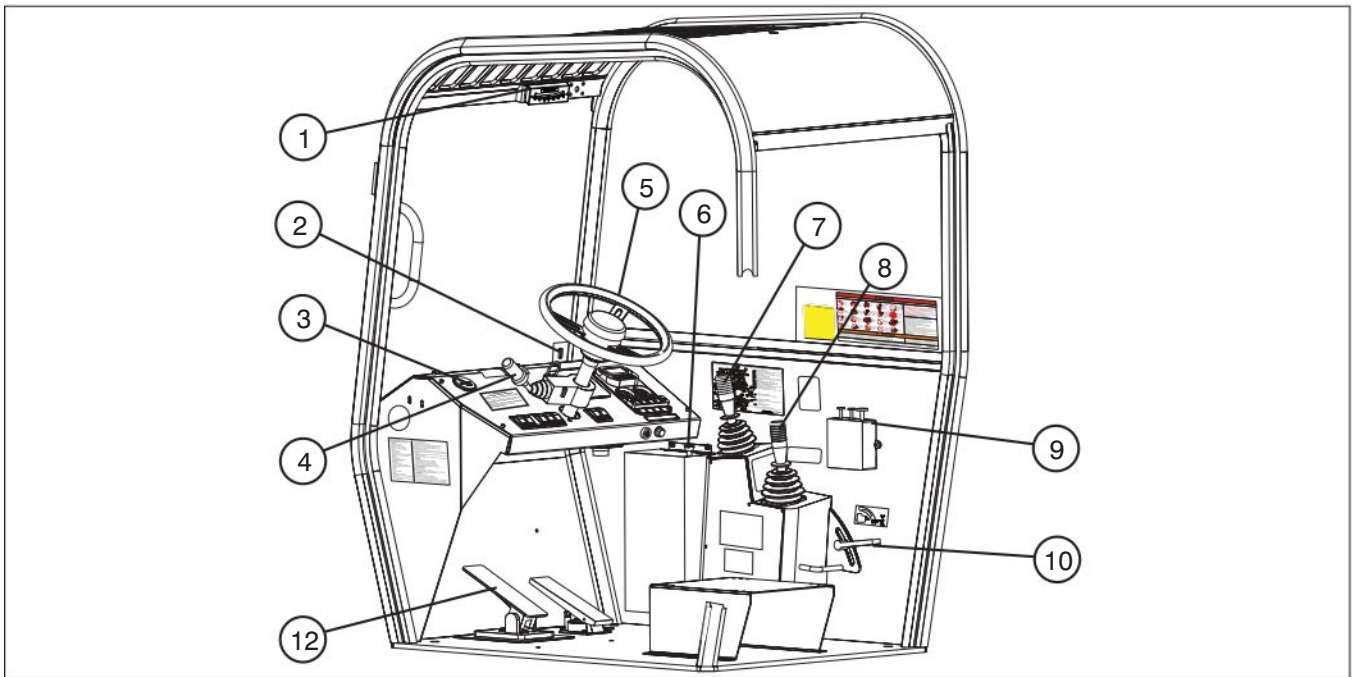

1. **Level Indicator** - This level indicator allows the operator to determine the left to right level condition of the telehandler.
2. **Wiper Switch (If equipped)** - This switch turns wiper on or off and has two speeds.
3. **Hourmeter** - This gauge records accumulated operating time of the telehandler.
4. **Transmission Control Lever** - This lever selects forward or reverse travel. The center position is neutral. To select forward travel, push lever forward; for reverse travel pull lever backward. Twist handle grip to select speed range.
5. **Steering Wheel** - Turn the steering wheel to the left or right to steer the telehandler in the corresponding direction. Three steering modes are available (refer to [Section 2.10-4](#)).
6. **Heater Fan switch (if equipped)** - This switch selects heater fan speed.
7. **Boom/Attachment Joystick** - This dual-axis lever controls the boom raise/lower and extend/retract functions. The lever returns to neutral when released. The thumb button on top of handle selects the attachment tilt function.  
  
To raise the boom, move joystick backward. To lower the boom, move joystick forward.  
  
To extend the boom, move joystick to the right. To retract the boom, move the joystick to the left.  
  
To tilt attachment forward, depress and hold thumb button while moving joystick forward. To tilt attachment backward, depress and hold thumb button while moving joystick backward.

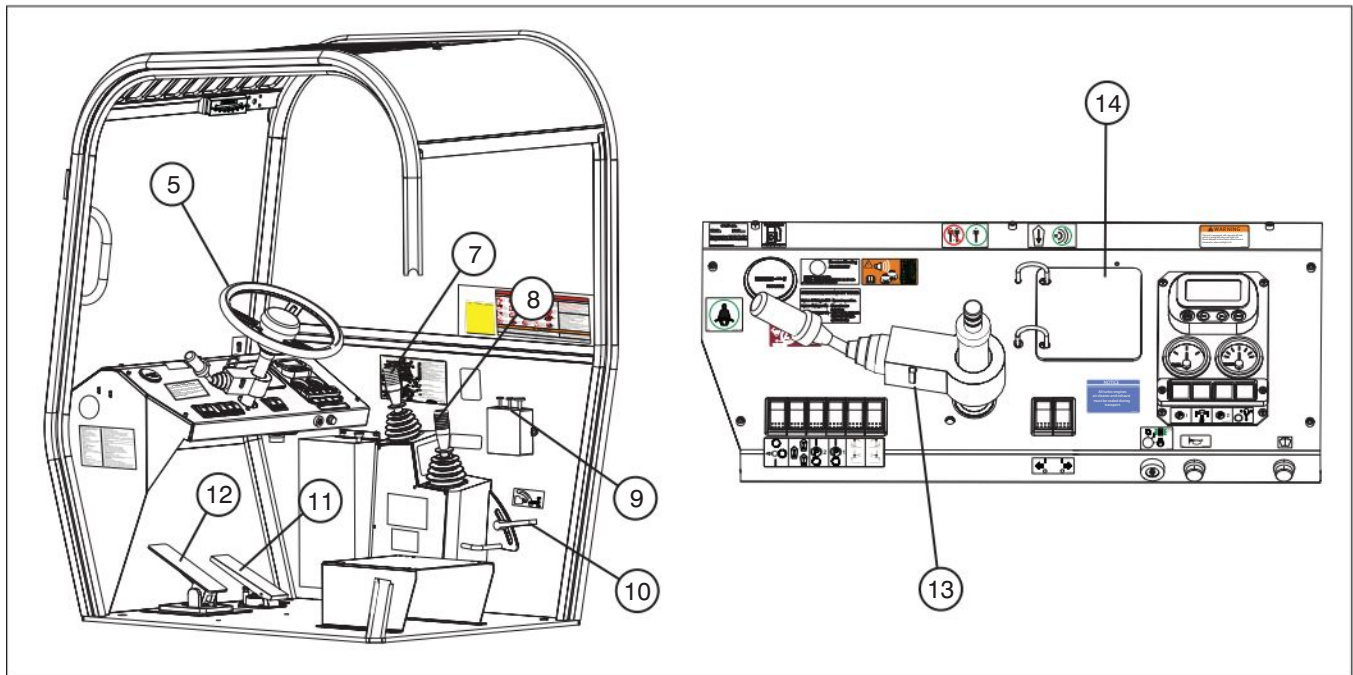

**8. Frame Level / Optional Attachment Joystick**

- This joystick controls the relationship of the telehandler frame to the front axle and controls optional attachments' functions. The lever returns to neutral when released.

- a) To level frame to the right, move joystick to the right "↗". Move joystick to the left "↖", to level frame to the left.
- b) Depress and hold the "☑" right thumb button on the rocker switch and move the joystick forward "↗" to operate a right-out function. Depress and hold the "☑" right thumb button and move joystick backward "↖" to operate a right-in function.
- c) Left-out function is operated by depressing and holding the "☑" left thumb button on rocker switch and moving joystick "↗" forward. Moving joystick "↖" backward while pressing and holding the left thumb button "☑" on rocker switch will operate a left-in function.

d) To operate a typical clamping or out function, move

joystick "↗" forward. Move joystick "↖" backward to operate an in function or to open a clamp.

Refer to [Section 2.15](#) for optional attachments operating instructions.

- 9. Light Switches (If Equipped)** - These switches turn lights on or off.
- 10. Boom Controller Console Lever** - This lever allows the operator to adjust the position of the controller box.
- 11. Accelerator Pedal** - Depress pedal to increase speed and release pedal to decrease speed.
- 12. Service Brake Pedal** - The service brake is foot operated and is used to decrease speed or stop.
- 13. Transmission Lever Neutral Lock Switch** - This two-position switch locks/unlocks forward or reverse movement of transmission lever.
- 14. Capacity Charts** - This set of charts indicates operating limits specific to a telehandler model and attachments. Refer to [Section 2.12](#).

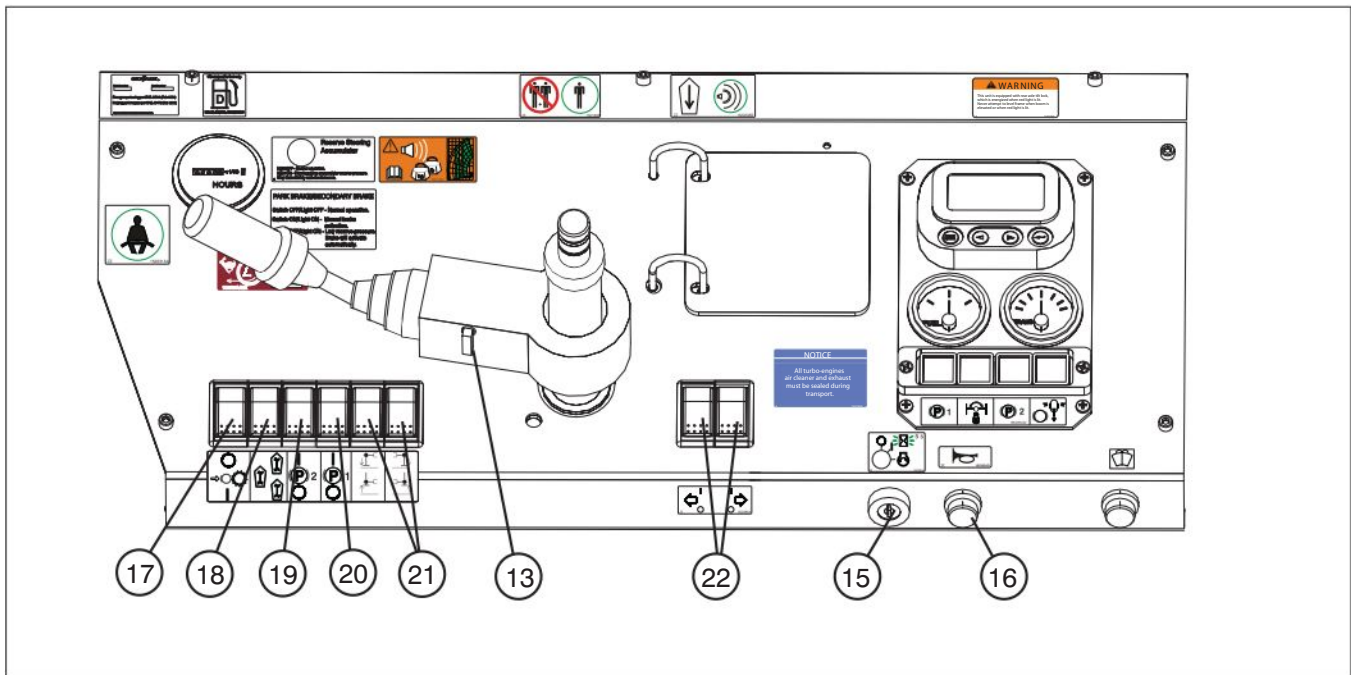

- 15. Ignition Switch** - This is a three-position, anti-restart switch.

When in “○” off position, it turns the engine off and key can be removed. When in “|” on position, it provides power to ignition and auxiliary circuits. When in “|” start position, it starts the engine; when released, key returns to “|” on position.

- 16. Horn Button** - This button sounds an automotive-type horn.

- 17. Transmission Disconnect Override** - This is a two-position rocker switch used for ramping operations only.

Select rocker switch to forward “” position for normal operation.

While in this position, the transmission will return to neutral automatically upon application of the brake.

Select rocker switch to backward “” position when operating on a slope.

While in this position, the transmission will remain in gear.

- 18. Steer Mode Switch** - This switch has three positions to allow selection of round steer, front steer and crab steer. Refer to [Section 2.10-4](#) for steering procedure.

- 19. Parking Brake Switch** - This switch controls the application and release of parking brake.

- 20. Secondary Park Brake Switch (If Equipped)** - This switch controls the application and release of secondary park brake.

- 21. Left and Right Outrigger Switches (If Equipped)** - These momentary switches control extension and retraction of left and right outriggers.

Select switches to forward “” position to extend outriggers.

Select switches to backward “” position to retract outriggers.

- 22. Left and Right Turn Signals (If Equipped)** - These rocker switches control left and right turn signals located on both the front and rear of the telehandler.

**NOTE**

Turn on both signals switches to use as emergency flashers.

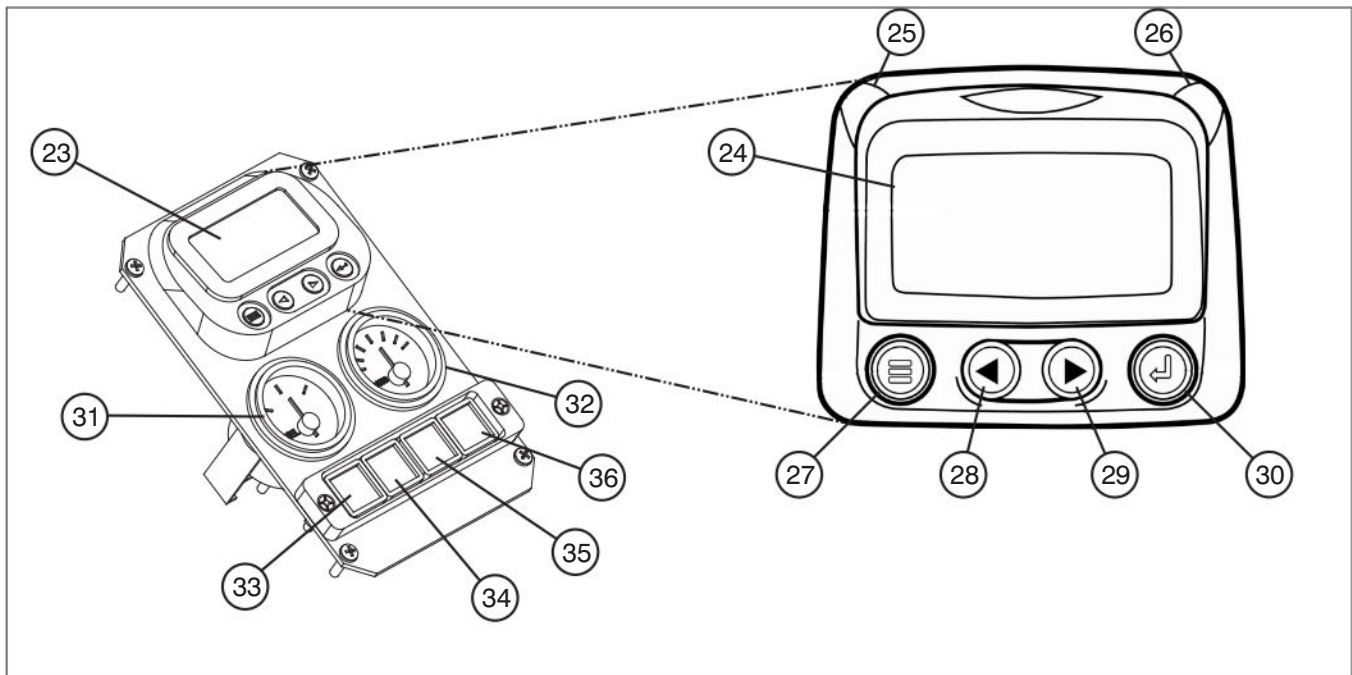

- 23. Powerview Electronic Dash Display** - This graphical LCD screen enables the operator to view engine parameters and service codes. The keypad on the Powerview is a capacitive touch sensing system. Refer to service manual for complete Powerview functions and operations.
- 24. PowerView Display** - Displays engine data information.
- 25. Amber LED** - Indicates engine warnings. Machine maintenance required.
- 26. Red LED** - Indicates engine derate/shutdown. Severe engine fault detected: shut off engine.
- 27. Menu Key** - Enter or exit menu screens.
- 28. Left Arrow Key** - Scroll the screen or move the parameter selection to the left or upward.
- 29. Right Arrow Key** - Scroll the screen and move the parameter selection to the right or downward.
- 30. Enter Key** - Select a menu or parameter or hide/view an active fault code.
- 31. Fuel Gauge** - This gauge displays level of fuel in fuel tank.
- 32. Transmission Oil Temperature Gauge** - This gauge displays transmission oil temperature.
- 33. Parking Brake Indicator Light** - This light indicates parking brake switch is activated.
- 34. Axle Lock Light** - This light indicates frame leveling is in slow/controlled mode, or locked mode when park and/or foot brakes are applied.
- 35. Secondary Park Brake Light (If Equipped)** - This light indicates secondary park brake switch is activated.
- 36. Brake Charge Pressure Light** - This light illuminates when service brake accumulator pressure in either side of the dual service brake system is low. Park telehandler safely and have it serviced immediately.



**2.6 Component Identification (Special Options)**

The following descriptions are for identification, explanation and locating purposes only.

**2.6-1 Main Power Disconnect Switch (If Equipped)**

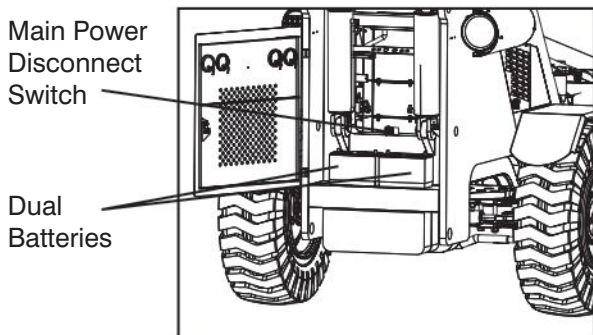

Figure 2-3 Main Power Disconnect Switch at rear of telehandler

This switch, when in “○” off position, disconnects power to all circuits. Switch must be in “|” on position to operate any circuit. Turn switch “○” off when transporting the telehandler.

**2.6-2 Optional Reserve Steering (If Equipped)**

The auxiliary steer system will temporarily maintain the steering pressure in the event of a engine failure or low pump output pressure.

When low pump output pressure is detected, a red warning light will illuminate on the dash and the solenoid valve in the reserve steering circuit will open allowing the reserve oil pressure into the steer system to maintain steering control. The telehandler should be brought to an immediate stop while steering control is still available.

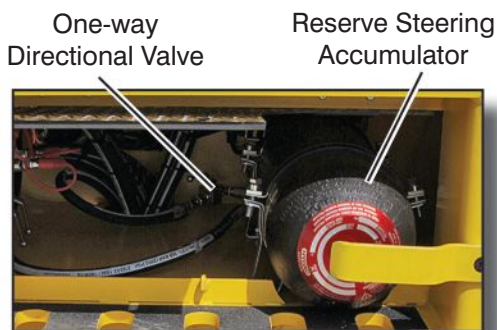

Figure 2-4 Reserve Steering Accumulator Under Operator's Cab

**NOTE**

When the ignition is turned off, the reserve oil in the accumulator is released to the steer system and may be heard as a swishing sound as the oil passes through the system. This is normal.

**2.6-3 Optional Secondary Park Brake (If Equipped)**

In addition to the dual service brake and the parking brake disc on the front axle pinion, telehandler equipped with these options include a secondary Spring Applied Hydraulically Released (SAHR) disc brake mounted to the rear axle pinion.

In the event of low service brake pressure, either one, or both pinion brakes will apply automatically. Also, a red light indicator on instrument cluster will warn the operator of low brake pressure.

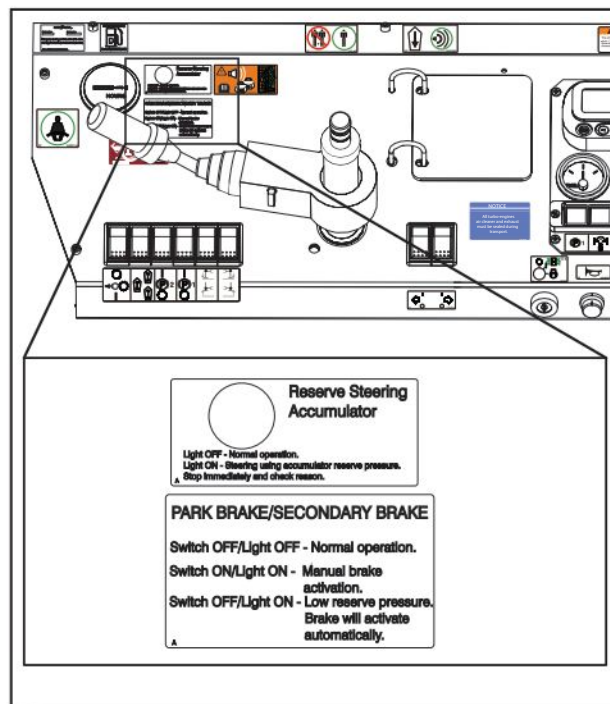

Figure 2-5 Reserve Steering & Park Brakes Labels

### 2.6-4 Positive Air Shutoff Switch (If Equipped)

This switch allows the operator to shut off the air supply to the engine if the engine continues running after the main power is shut down.

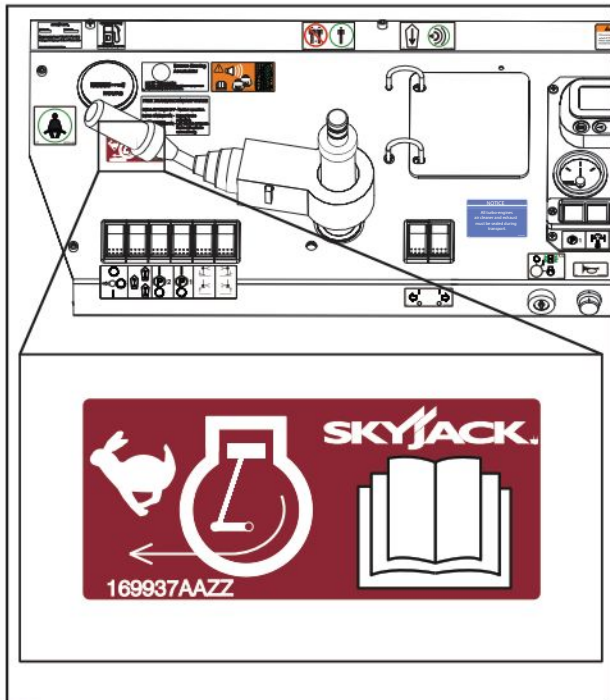

Figure 2-6 Positive Air Shutoff Label

## 2.7 Operator's Responsibility

It is the responsibility of the operator, prior to each work shift, to perform the following:

### 1. Visual and Daily Maintenance Inspections

- Designed to discover any damage of components before the telehandler is put into service.
- Completed before the operator performs the function tests.



### **WARNING**

**Failure to locate and repair damage, and discover loose or missing parts may result in an unsafe operating condition.**

### 2. Function Tests

- Designed to discover any malfunctions before the telehandler is put into service.

### **IMPORTANT**

**The operator must understand and follow the step-by-step instructions to test all telehandler functions.**

The operator should make a copy of the Operator's Checklist (see [Table 2.6](#)) and fill out the visual and daily maintenance inspections and the function tests sections while performing the items outlined in [Section 2.8](#) and [Section 2.9](#).

### **IMPORTANT**

**If telehandler is damaged or any unauthorized variation from factory-delivered condition is discovered, telehandler must be tagged and removed from service.**

Repairs to the telehandler may only be made by a qualified service technician. After repairs are completed, the operator must perform visual and daily maintenance inspections & function tests again.

Scheduled maintenance inspections shall only be performed by a qualified service technician (see [Table 2.5](#)).

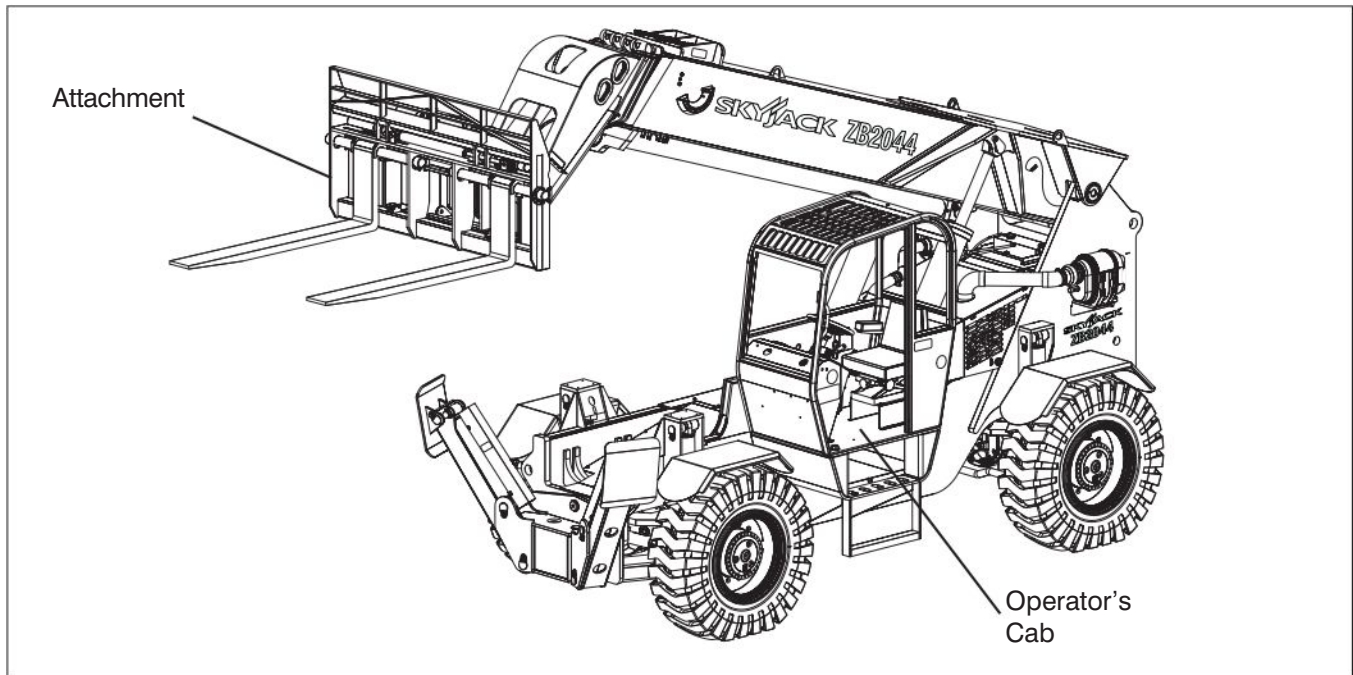

## 2.8 Visual & Daily Maintenance Inspections

Before performing the visual and daily maintenance inspections, ensure that the telehandler is parked on a firm level surface.

Begin the visual and daily maintenance inspections by checking each item in sequence for the conditions listed in this section.



### **WARNING**

**To avoid injury, do not operate a telehandler until all malfunctions have been corrected.**



### **WARNING**

**To avoid possible injury, ensure telehandler power is off during your visual and daily maintenance inspections.**

### **NOTE**

While performing visual and daily inspections in different areas, be aware to also inspect all switches, electrical and hydraulic components.

### 2.8-1 Labels

Refer to the labels section in this manual and determine that all labels are in place and are legible.

### 2.8-2 Electrical

Maintaining the electrical components is essential to good performance and service life of the telehandler.

- Ensure proper operation of all gauges
- Check charging system Ammeter/Voltmeter
- Inspect the following areas for chafed, corroded and loose wires:
  - boom wiring harnesses
  - frame wiring harnesses
  - cab wiring harnesses

Ensure electrical devices are properly secured with no signs of visible damage. Ensure there are no loose or missing parts.

### 2.8-3 Safety Switches

Ensure safety switches are properly secured with no signs of visible damage.

### 2.8-4 Mirrors

Ensure mirrors are properly secured with no signs of visible damage.

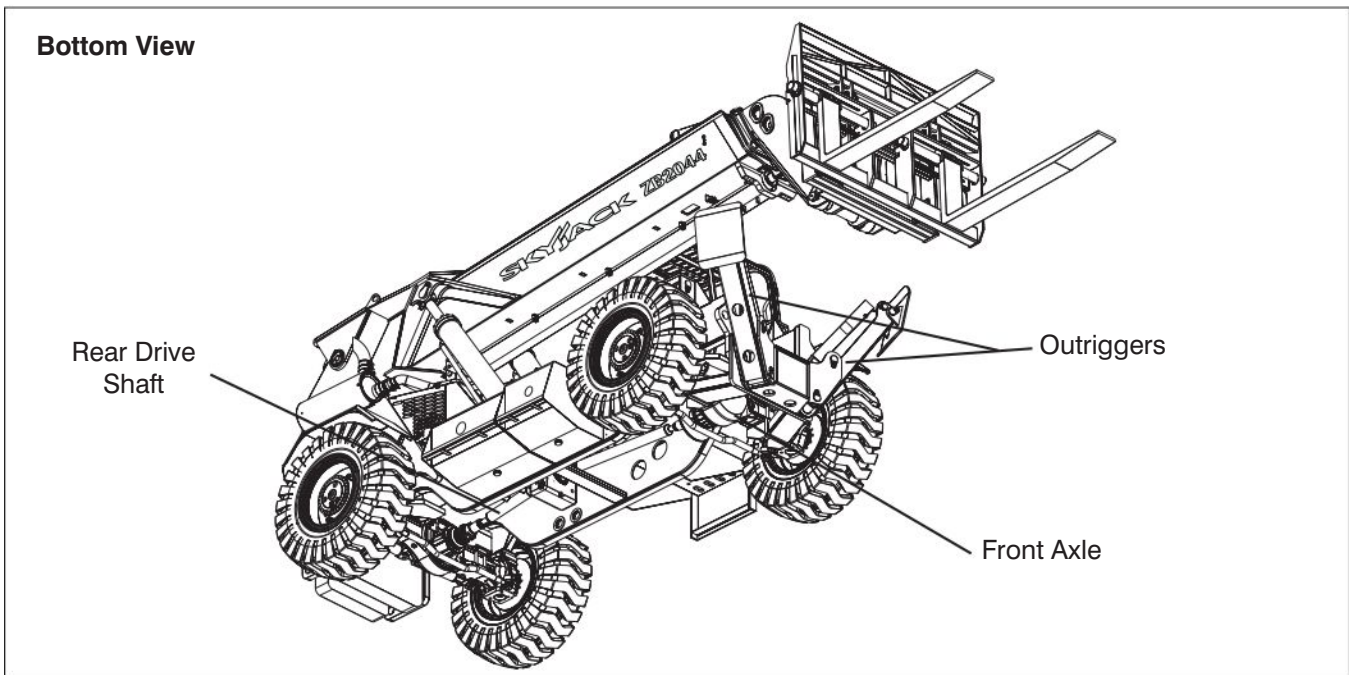

**2.8-5 Hydraulic**

Maintaining the hydraulic components is essential to good performance and service life of the telehandler. Perform a visual inspection and check for leaks around the following areas:

- hydraulic tank, filter(s), fittings, hoses, pump, and frame surface
- all hydraulic cylinders
- all hydraulic manifolds
- underside of the frame
- ground area under the telehandler

- Check all tire treads and sidewalls for cuts, cracks, punctures and unusual wear.
- Check each wheel for damage and cracked welds.
- Check each lug nut for proper torque to ensure none are loose.

To safeguard maximum stability, achieve optimum telehandler handling and minimize tire wear, it is essential to maintain proper pressure in all air-filled tires.

**2.8-6 Cylinders**

- Ensure all cylinders are properly secured and there is no evidence of leakage.
- Grease weekly and check pins and bushings to ensure there is no evidence of damage.

- Check each tire with an air pressure gauge and add air as needed.

**2.8-7 Frame**

**• Wheel/Tire Assembly**

The telehandler is either equipped with air tires or foam-filled tires. Tire and/or wheel failure could result in a telehandler tipover. Component damage may also result if problems are not discovered and repaired in a timely fashion.

- **Drive Axle**
  - Ensure drive axle is properly secured, there are no loose or missing parts, all fittings and hoses are properly tightened and there is no evidence of oil leakage.

**• Steer Cylinder Assembly**

- Ensure steer cylinder assembly is properly secured, there are no loose or missing parts, all fittings and hoses are properly tightened and there is no evidence of hydraulic oil leakage.

**• Steer Linkage**

- Ensure there are no loose or missing parts, steer linkage studs are locked and there is no visible damage.



**WARNING**

**An over-inflated tire can explode and may cause death or serious injury.**

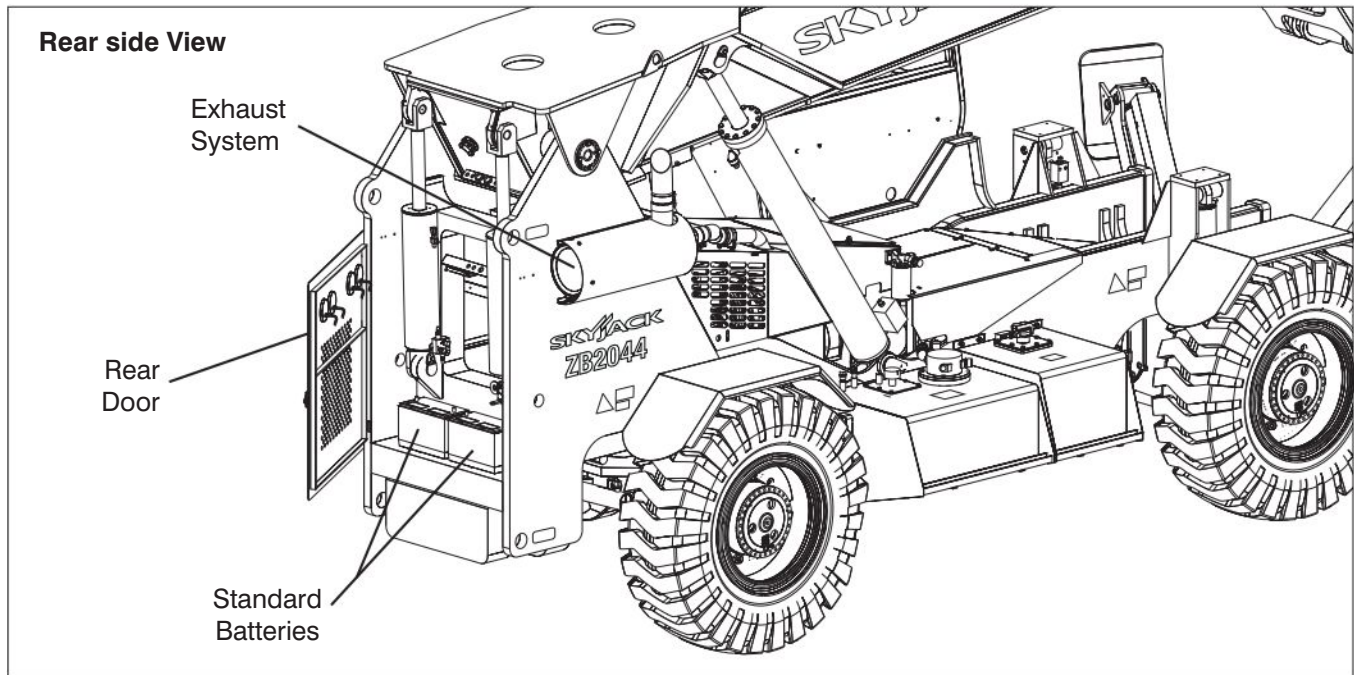

- **Batteries**

Proper battery condition is essential to good engine performance and operational safety. Improper fluid levels or damaged cables and connections can result in engine component damage and hazardous conditions.



**WARNING**

Explosion hazard. Keep flames and sparks away. Do not smoke near batteries.



**WARNING**

Battery acid is extremely corrosive - Wear proper eye and facial protection as well as appropriate protective clothing. If contact occurs, immediately flush with cold water and seek medical attention.

1. Check batteries case for damage.
2. Clean terminals and cable ends thoroughly with a terminal cleaning tool or wire brush.
3. Ensure all connections are tight.
4. If applicable, check battery fluid level. If plates are not covered, add distilled or demineralized water.

5. Replace batteries if damaged or incapable of holding a lasting charge.



**WARNING**

Use original or manufacturer-approved parts and components for the telehandler.

- **Engine Air Filter**

- Ensure there are no loose or missing parts and there is no visible damage.
- Ensure air cleaner vacuator valve (if applicable) is free from dirt or dust by squeezing the valve lips.

- **Engine Coolant**

- The coolant level should be between the minimum and maximum marks. Add coolant as needed. Refer to your engine manual for recommended coolant mixture. Refer to [Section 2.17](#) for coolant level maintenance.

- **Muffler and Exhaust**

- Ensure muffler and exhaust systems are properly secured, with no evidence of damage.

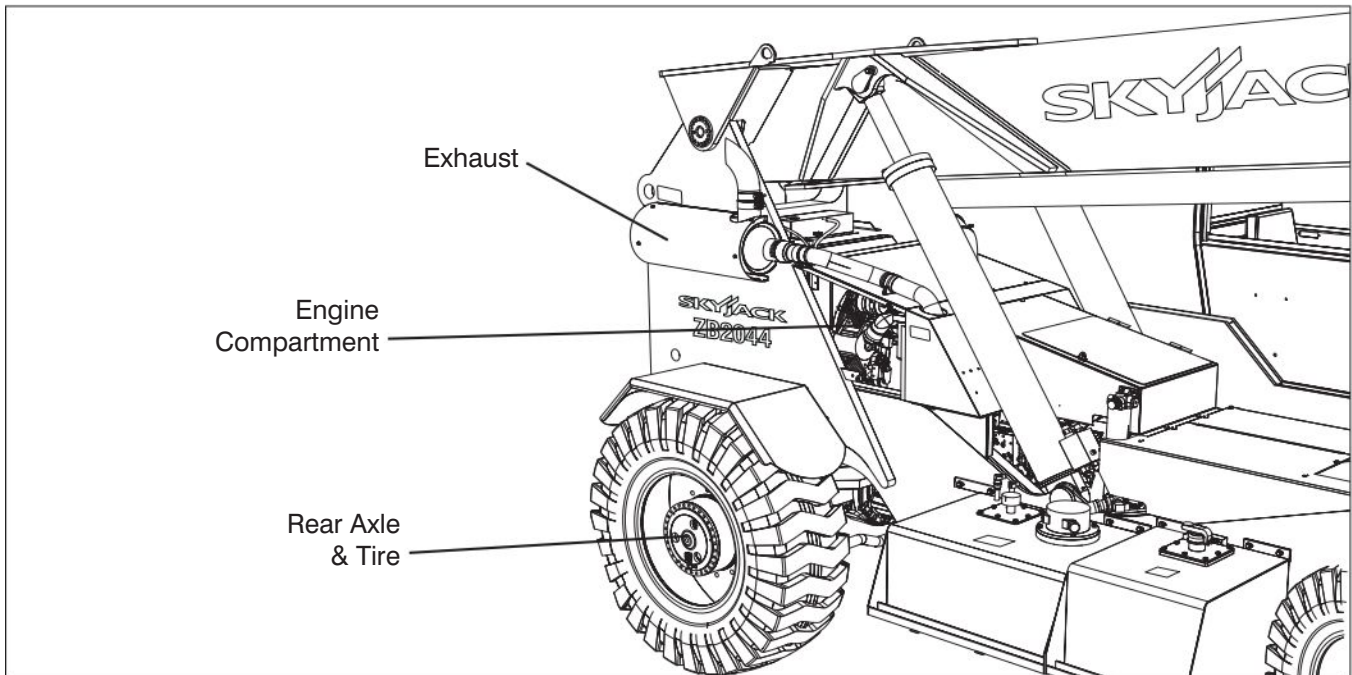

**2.8-8 Engine Compartment**

- Ensure compartment cover is secure and in proper working order.
- **Engine Oil Level**
  - Maintaining the engine components is essential to good performance and service life of the telehandler.



**WARNING**

**Beware of hot engine components.**

**Check oil level on dipstick**

- Oil level should be in the “safe” zone. Add oil as needed. Refer to [Table 2.4](#) for recommended oil type.

- **Fuel Leaks**

Failure to detect and correct fuel leaks will result in an unsafe condition. An explosion or fuel fire may cause death or serious injury.



**DANGER**

**Engine fuels are combustible. Inspect the telehandler in an open, well-ventilated area away from heaters, sparks and flames. Always have an approved fire extinguisher within easy reach.**

Perform a visual inspection around the following areas:

- hoses and fittings
- fuel pump
- fuel filter
- fuel tank
- **Hydraulic Pumps**
  - Ensure there are no loose or missing parts and there is no visible damage.
  - Ensure all bolts are properly tightened.
  - Ensure all fittings and hoses are properly tightened and there is no evidence of hydraulic oil leakage.
- **Belts**
  - Ensure belts are in good working condition and have correct tension. Replace if belts are cracked, frayed, or have chunks of material missing. Refer to engine manufacturer’s manual for proper replacement procedure.

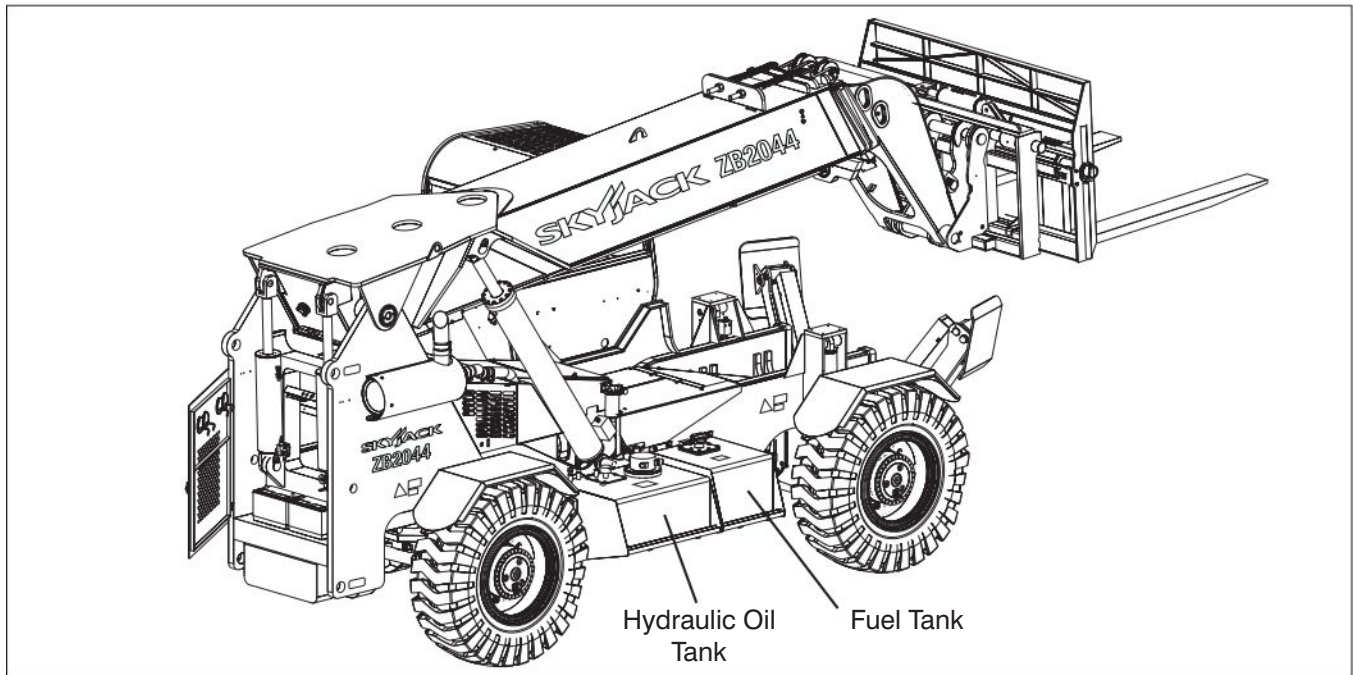

- **Fuel Tank**

**IMPORTANT**

**Before using your telehandler ensure there is enough fuel for expected use.**

- Ensure fuel filler cap is secure.
- Ensure tank shows no visible damage and no evidence of fuel leakage.

- **Hydraulic Tank**

- Ensure hydraulic filler cap is secure.
- Ensure tank shows no visible damage and no evidence of hydraulic leakage.

- **Hydraulic Oil**

- Be sure that the boom is in the stowed position, and then visually inspect the sight gauge located on the side of the hydraulic oil tank.
- The hydraulic oil level should be between the minimum and maximum marks on the sight glass. Add oil as needed. Refer to [Table 2.4](#) for recommended oil type.

- **Hydraulic Return Filter**

- Ensure filter element is secure.
- Ensure there are no signs of leakage or visible damage.

- **2.8-9 Transmission**

- Ensure transmission shifter is working properly and there is no evidence of damage.
- **Check oil level on dipstick**
  - Oil level should be in the “safe” zone. Add oil as needed. Refer to [Table 2.4](#) for recommended oil type.

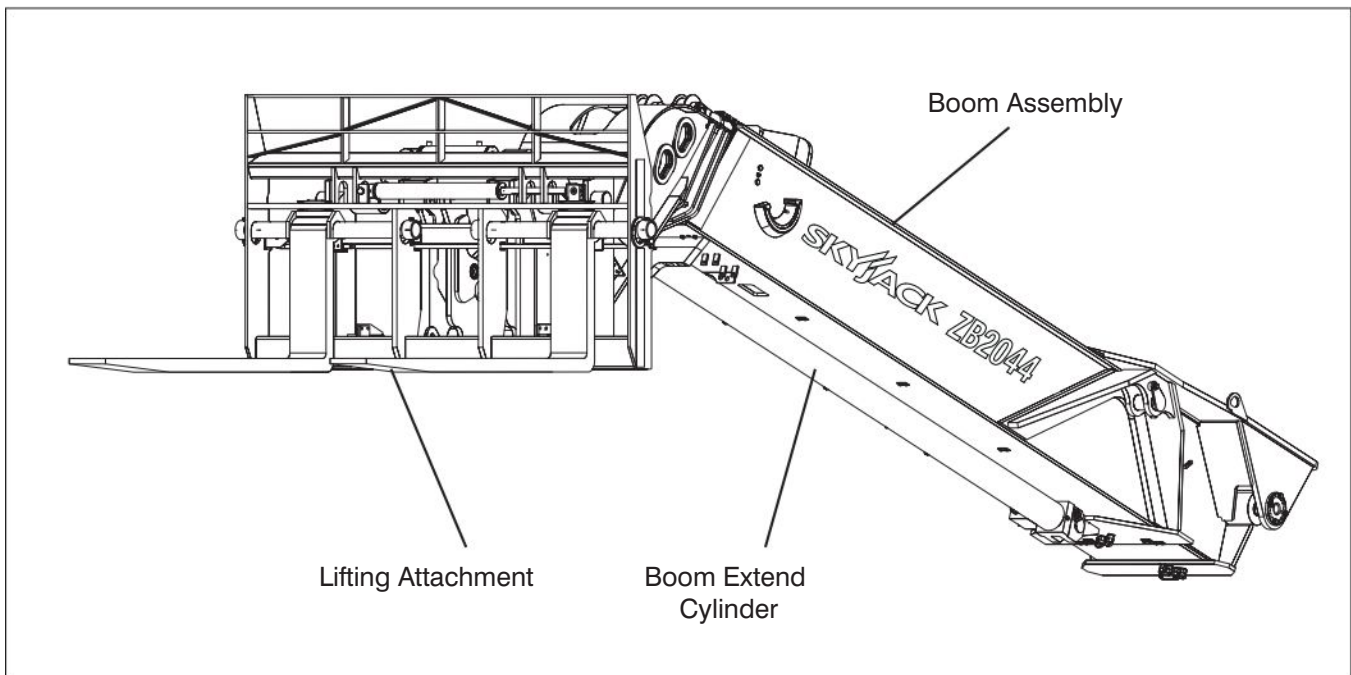

### 2.8-10 Boom

- Ensure there are no loose or missing parts and there is no visible damage.
- Ensure all bolts and pins are properly tightened.
- Ensure there are no visible cracks in welds or structure and there are no signs of deformation.
- Ensure all hoses are properly tightened and there is no evidence of hydraulic leakage.
- **Slide Pads**
  - Ensure all bolts are tight, there is no visible damage to the slide pads and that no parts are missing.
- **Chain**
  - Ensure there are no loose or missing parts and there is no visible damage
- **Boom Angle Indicator**
  - Ensure all bolts are tight, and there is no visible damage

### 2.8-11 Lifting Attachment

- Ensure there are no loose or missing parts and there is no visible damage.
- Ensure attachment is properly positioned and secured. (refer to [Section 2.15](#) for attachments)

### 2.8-12 Grease Points

Maintaining properly greased components is essential for good performance and service life of the telehandler. If components are improperly greased, it could result in component damage.



#### **WARNING**

**Ensure that there are no personnel or obstructions in maintenance area.**

Greasing intervals are based on telehandler usage of 40 hours. Use of telehandler may vary significantly and greasing frequency must be adjusted to obtain maximum service life.

Refer to service manual for complete list of grease points locations and greasing schedule.

Refer to [Table 2.4](#) for recommended fluids and lubricants.



### Axle Grease Points

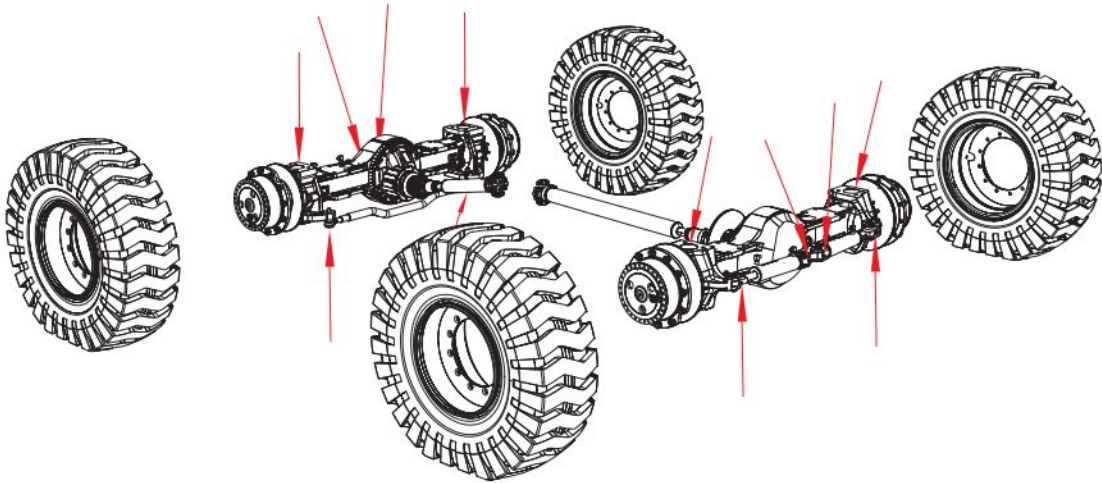

### Grease Points on Frame

1. Ensure telehandler is on a firm level surface and is in stowed position.
2. Locate grease fittings (refer to label inside operator's cab) and pump grease in the following:
  - axle pivot bearings (front and rear)
  - axle lock cylinder (top and bottom)
  - lift cylinder (top and bottom, both sides)
  - frame level cylinders (top and bottom)
  - outrigger pins
  - slave cylinders (top and bottom)
3. Using a creeper, slide under the frame to locate grease fittings and pump grease in the following:
  - drive shaft U-joint (front and rear)
  - slip joint on drive shaft (front and rear)

### Grease Points on Boom Assembly

1. Ensure telehandler is on a firm level surface and is in stowed position.
2. Locate grease fittings (refer to label inside operator's cab) and pump grease in the following:
  - main boom pivot bearing pins
  - retract chain rollers
  - hose rollers
  - extension chains and rollers
  - slide pads
  - attachment tilt cylinders (top and bottom)
  - attachment pivot bearings

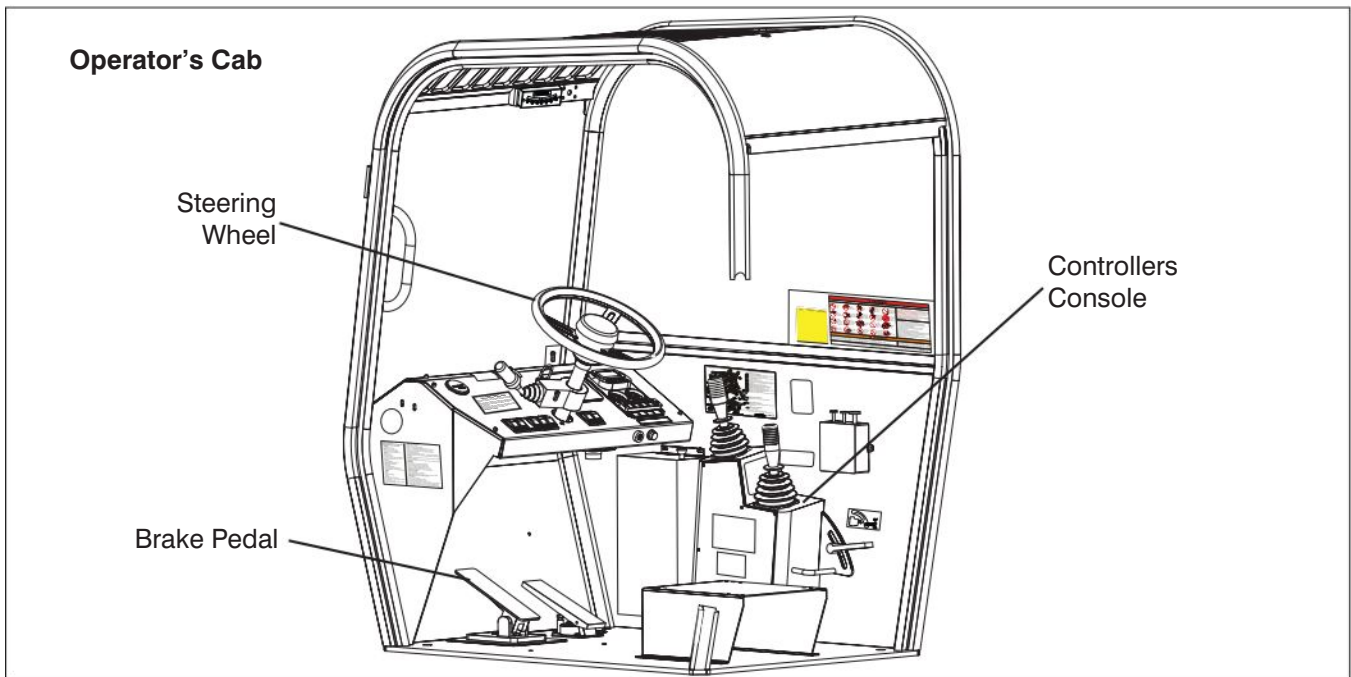

**2.8-13 Operator's Cab**

- **Rollover and Falling Object Protective Structure (ROPS/FOPS)**
  - Ensure there is no visible damage.



**WARNING**

**Do not modify, drill or alter the operator's cab in any way.**

- **Seat**
  - Ensure seat is properly secured with no sign of visible damage.
  - Ensure seat belt is working properly with no sign of visible damage.
- **Pedals**
  - Ensure brake and accelerator pedals are secure, no loose or missing parts, no sign of visible damage and movements are not obstructed.
- **Manual**
  - Check to be sure manual storage box is present and in good condition.
  - Ensure a copy of operating manual, and other important documentation are enclosed in manual storage box.
  - Ensure manual is legible and in good condition.

- Always return manual to the manual storage box after use.

- **Operator's Cab Controls**



**WARNING**

**Ensure that you maintain three points of contact to mount/dismount the cab.**

Use the steps of telehandler to access operator's cab.

- Ensure door and windows (if equipped) are secure and in proper working order.
- Ensure steering wheel is secured with no sign of visible damage.
- Ensure all switches and controls are properly secured with no sign of visible damage.
- Ensure all switches and controls are returned to their neutral positions and movements are not obstructed.
- Ensure capacity charts are in place and are legible.



**DANGER**

**Do not operate the telehandler if capacity charts are missing or not legible.**

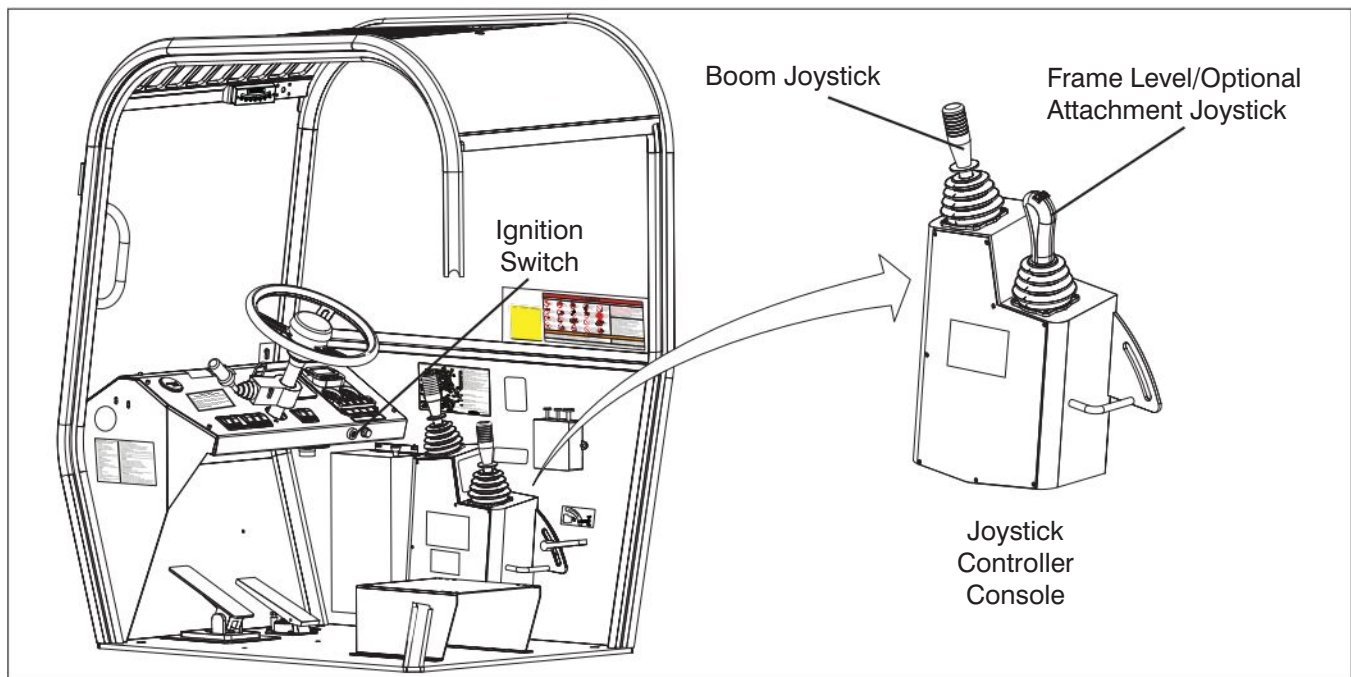

## 2.9 Function Tests

Function tests are designed to discover any malfunctions before telehandler is put into service. The operator must understand and follow step-by-step instructions to test all telehandler functions.

### **IMPORTANT**

**Never use a malfunctioning telehandler. If malfunctions are discovered, telehandler must be tagged and placed out of service. Repairs to telehandler may only be made by a qualified service technician.**

After repairs are completed, operator must perform a pre-operation inspection and a series of function tests again before putting telehandler into service.

Prior to performing function tests, be sure to read and understand [Section 2.10 - Start Operation](#).



### **WARNING**

**Ensure that there are no personnel or obstructions in test area and that there is sufficient room to test all telehandler functions.**

### 2.9-1 Operator's Cab Controls



### **WARNING**

**Ensure that you maintain three points of contact to mount/dismount the cab.**

- **Test Starter Operation**

1. Enter cab and close door (if equipped).



### **WARNING**

**The seat belt must be worn at all times.**

2. Sit in the driver's seat and fasten seat belt.
3. Using a spotter, adjust the mirrors.
4. Ensure parking brake is engaged.
5. Adjust the boom controller console.
6. Insert key into ignition switch and select "I" on position. The red and amber lights at the top of electronic dash display will illuminate. Once red and amber lights are no longer displayed, and the electronic gauges are visible on the display panel; turn the key to start position.
7. Allow engine to idle for 30 seconds until low brake pressure light is off.

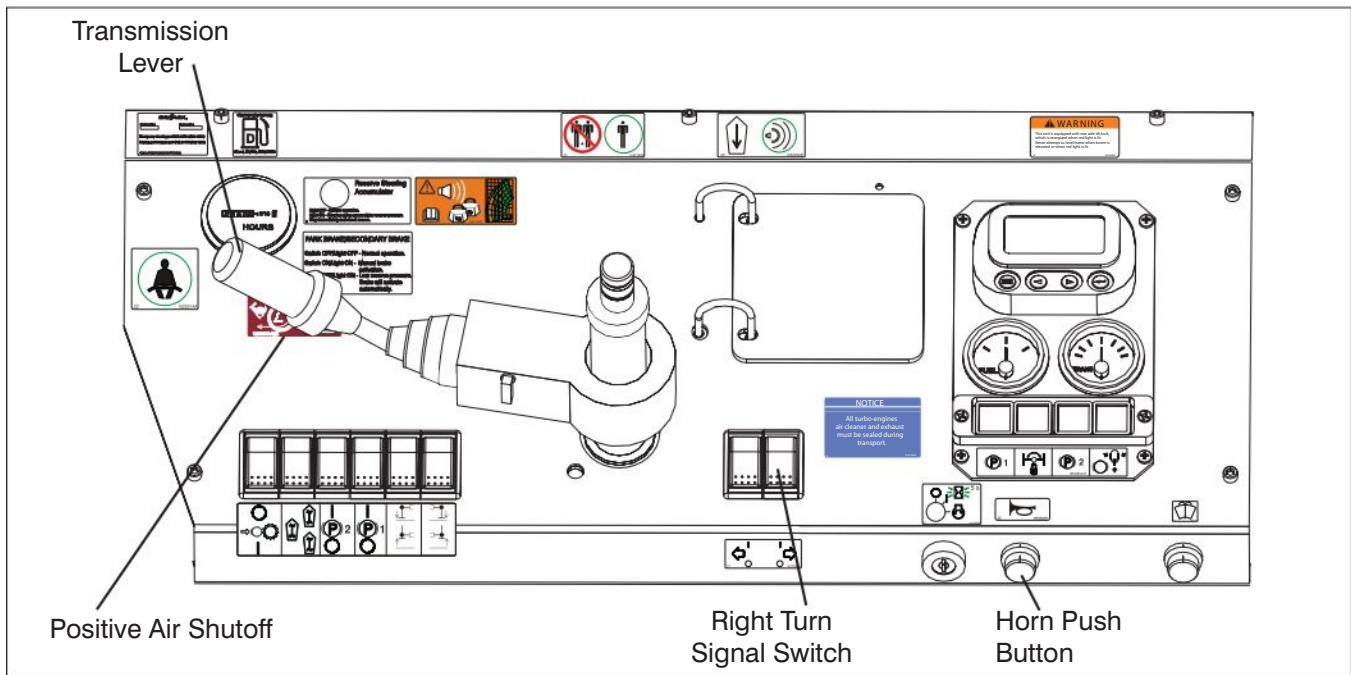

• **Test Horn**

1. Push “” horn push-button.  
**Result:** Horn should sound.



**WARNING**

**If the warning indicator lights illuminate when engine is running, immediately shut down the telehandler and have it serviced.**

• **Test Reverse Alarm**

1. Ensure parking brake switch is on.
2. Depress service brake pedal and shift the transmission lever backward.  
**Result:** The reverse alarm should sound and reverse light (if equipped) should turn on.

• **Test Positive Air Shutoff (If Equipped)**

**CAUTION**

**This function test should not be performed while the engine is running.**

1. Open the engine cover on the hydraulic tank side of the machine.
2. Lift switch guard and push rocker switch to “on” position. Walk back to the hydraulic tank side of the machine.  
**Result:** With a flashlight, inspect the shutoff valve. After 20 seconds the valve should disengage.

3. Close engine cover.

4. Ensure switch is returned to “off” position and switch guard is down.

• **Test Lights (If Equipped)**

1. Use a spotter to check if all the lights are working well. The spotter should maintain a safe distance from telehandler.
2. Turn parking brake switch to off position.  
**Result:** Rear brake lights should turn off.
3. Depress service brake pedal.  
**Result:** Rear brake lights should turn on.
4. Select head/tail light (if equipped) switch to on position.  
**Result:** Head/tail lights should turn on.
5. Turn parking brake switch to on position.
6. Select left turn signal (if equipped) rocker switch to on position.  
**Result:** The left signal light should flash.
7. Select right turn signal (if equipped) rocker switch to on position.  
**Result:** The right signal light should flash.

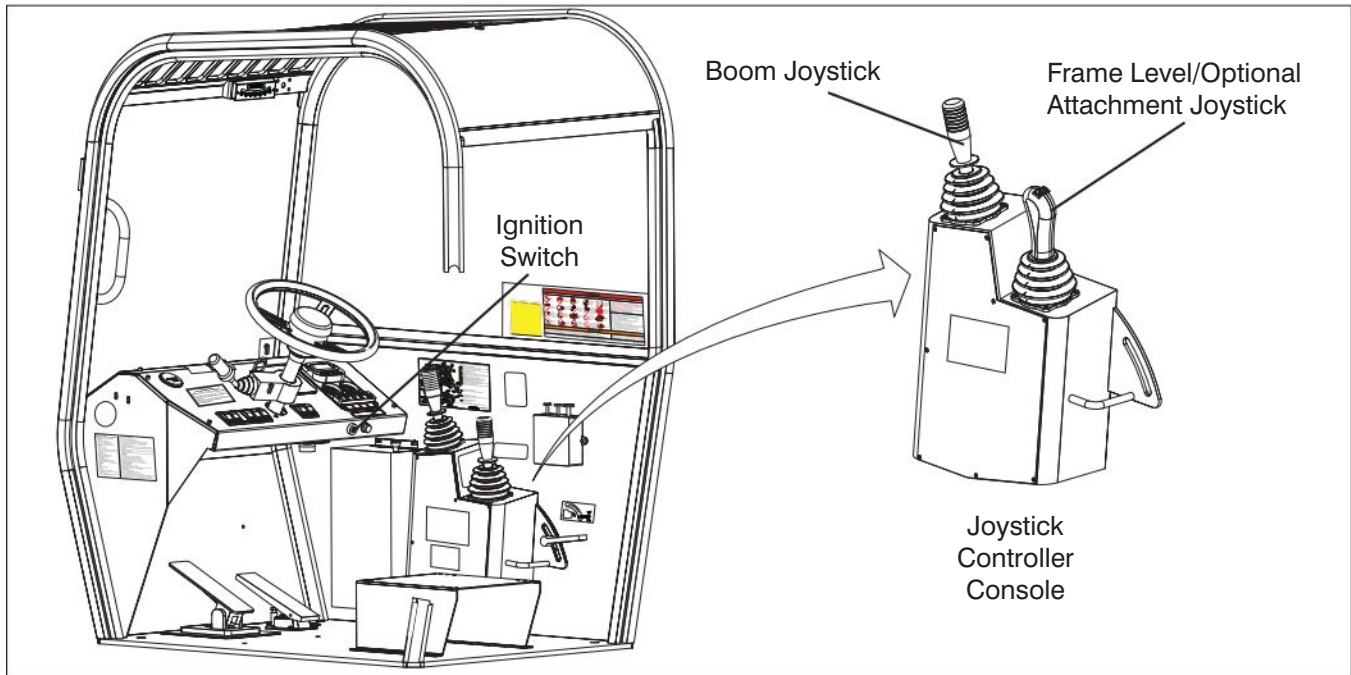

- **Test Boom and Attachment Functions**

**WARNING**

Ensure that there are no personnel or obstructions in test area and that there is sufficient room to test all telehandler functions.

1. Ensure the parking brake indicator light is on.
2. Raise the boom by pulling the boom/attachment joystick backward.  
**Result:** Boom should raise and boom angle indicator should be functioning.
3. Extend the boom by moving the boom/attachment joystick to the right.  
**Result:** Boom should extend and boom extension indicators are visible.
4. Tilt attachment forward by pressing and holding the thumb button while moving joystick forward.  
**Result:** Attachment should tilt forward.
5. Tilt attachment backward by pressing and holding the thumb button while moving joystick backward.  
**Result:** Attachment should tilt backward.
6. Retract the boom by moving the boom/attachment joystick to the left.  
**Result:** Boom should retract.
7. Lower the boom by moving the boom/attachment joystick forward.  
**Result:** Boom should lower.
8. Raise the boom until attachment is 2 feet above the ground.

**IMPORTANT**

Test all attachment functions if telehandler is equipped with optional attachments. Refer to Section 2.15 for optional attachments operation.

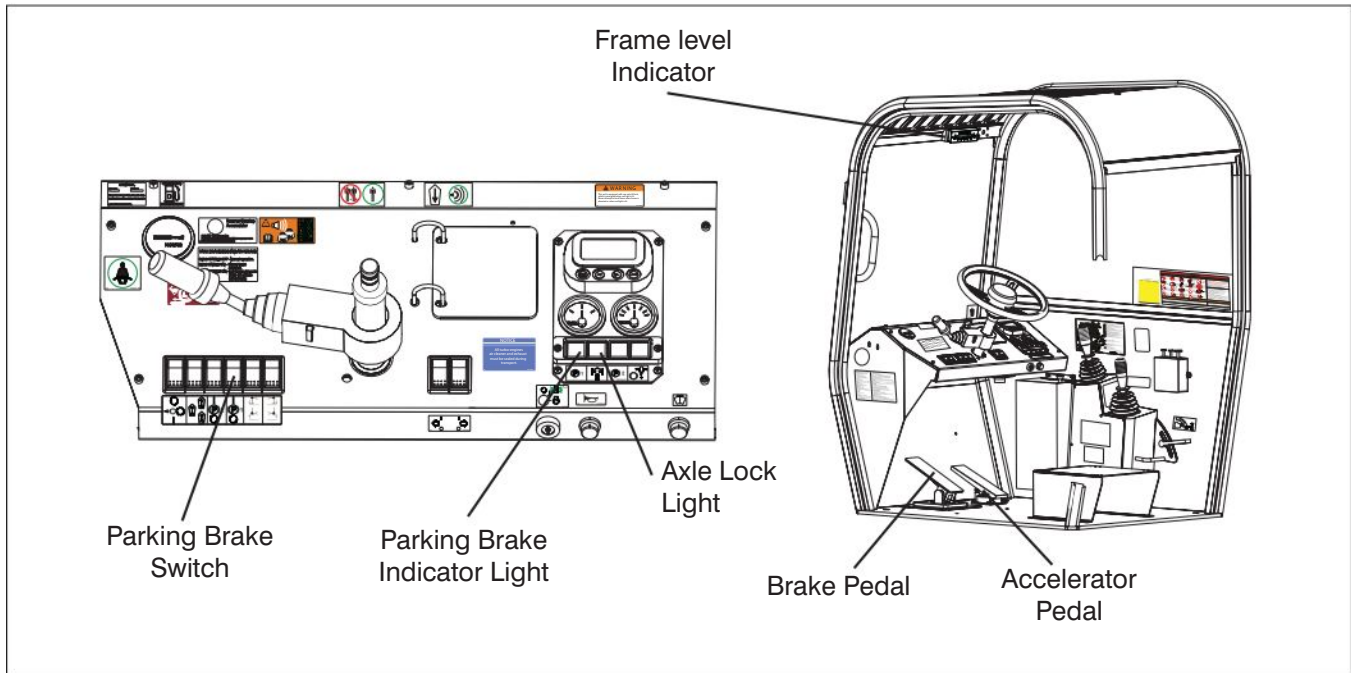

- **Test Frame Leveling and Level Indicator**

1. Ensure parking brake switch is on.
2. Tilt frame to the right by moving frame level joystick to the right.  
**Result:** Frame should tilt to the right.
3. Tilt frame to the left by moving frame level joystick to the left.  
**Result:** Frame should tilt to the left.
4. Use the frame level indicator to ensure frame is level.

- **Test Rear Axle Lock**

1. Ensure parking brake switch is on.
2. Raise boom above 45° - boom angle and attempt leveling the frame to the right or to the left.  
**Result:** Rear axle lock light should illuminate and frame should not tilt to right or left.
3. Lower the boom until attachment is 2 feet above the ground.

- **Test Accelerator Pedal**

1. Ensure parking brake switch is on.
2. Depress accelerator pedal slowly.  
**Result:** The engine RPM should increase.
3. Release the accelerator pedal.  
**Result:** The engine RPM should decrease.

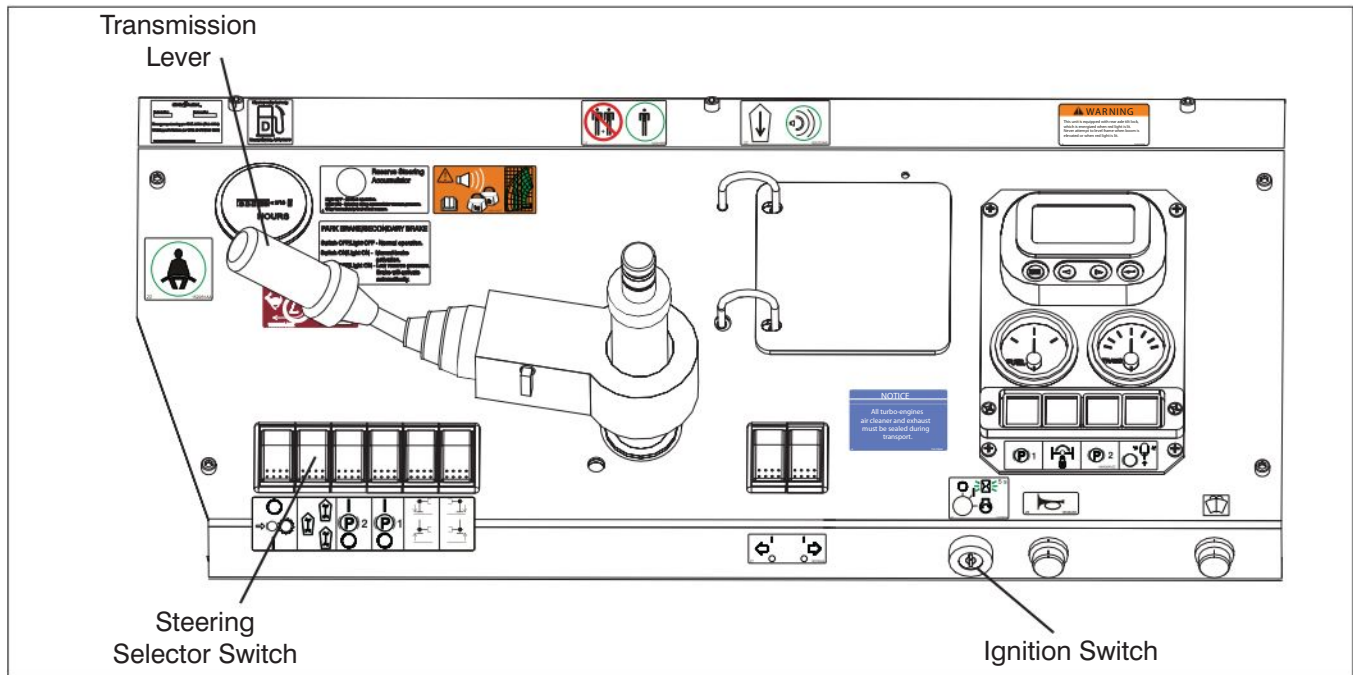

- **Test Driving & Service Brake Functions**

1. Ensure path of intended motion is clear.
2. Ensure all four wheels are aligned straight ahead.
3. Depress service brake pedal.
4. Release parking brake.  
**Result:** Parking brake indicator light should turn off.
5. Shift transmission lever forward and release the service brake pedal slowly.  
**Result:** Telehandler should move forward.
6. Depress service brake pedal slowly.  
**Result:** Telehandler should stop.
7. Shift transmission lever backward and release the service brake pedal slowly.  
**Result:** Telehandler should move backward.
8. Depress service brake pedal slowly.  
**Result:** Telehandler should stop.
9. Return transmission lever to neutral position and engage parking brake.

- **Test Steering**

**CAUTION**

Before changing steering modes, bring all four wheels into alignment (i.e., in the straight-ahead position).

**WARNING**

Before driving on public roads and highways check the alignment of the wheels and drive with FRONT steering only.

**WARNING**

Do not change steer mode while telehandler is traveling.

**NOTE**

Avoid steering the wheels while telehandler is stationary.

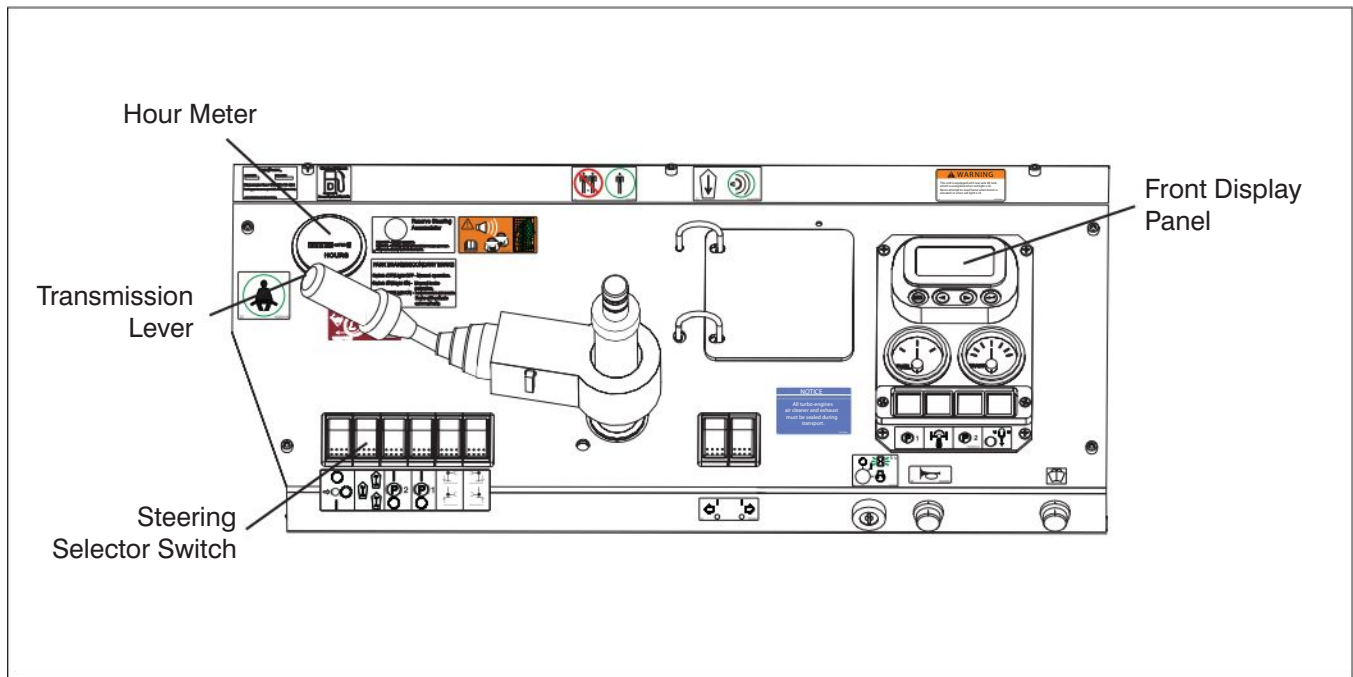

**Round Steer**

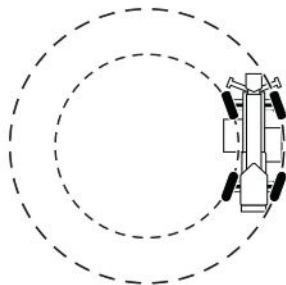



Figure 2-7 Round Steering

1. Ensure path of intended motion is clear.
2. Ensure all four wheels are aligned straight ahead.
3. Select parking brake switch to off position and depress service brake pedal.
4. Select rocker switch to forward “” position for round steering.
5. Turn the steering wheel to the left or right and drive forward.

**Result:** Telehandler should move in the chosen direction, producing a turning circle, with front wheels pointing in the opposite direction to the rear wheels.

6. Steer the telehandler straight ahead until all four wheels are aligned.
7. Depress service brake pedal until the telehandler stops.

**Front Steer**

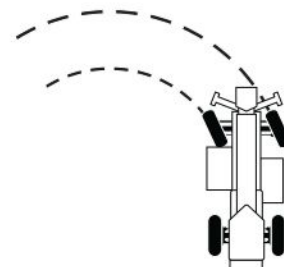

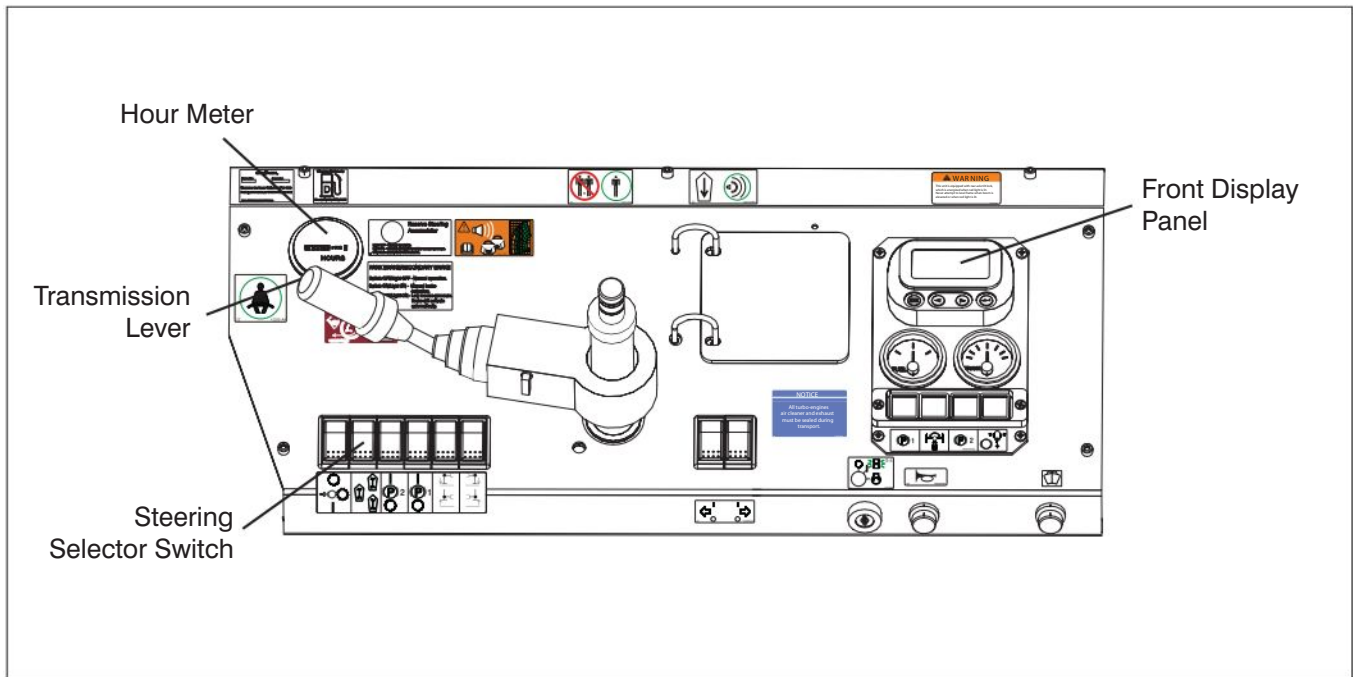

Figure 2-8 Front Steering

8. Select rocker switch to middle “” position for front steering.
9. Turn the steering wheel to the left or right and drive forward.

**Result:** Only front wheels of the telehandler should turn in the chosen direction.





- 10. Steer the telehandler straight ahead until all four wheels are aligned.
- 11. Depress service brake pedal until the telehandler stops.

- 13. Turn the steering wheel to the left or right and drive forward.  
**Result:** Telehandler should move in the chosen direction with both front and rear wheels in the same direction.

**Crab Steer**

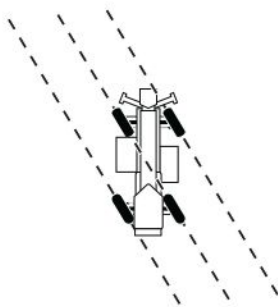

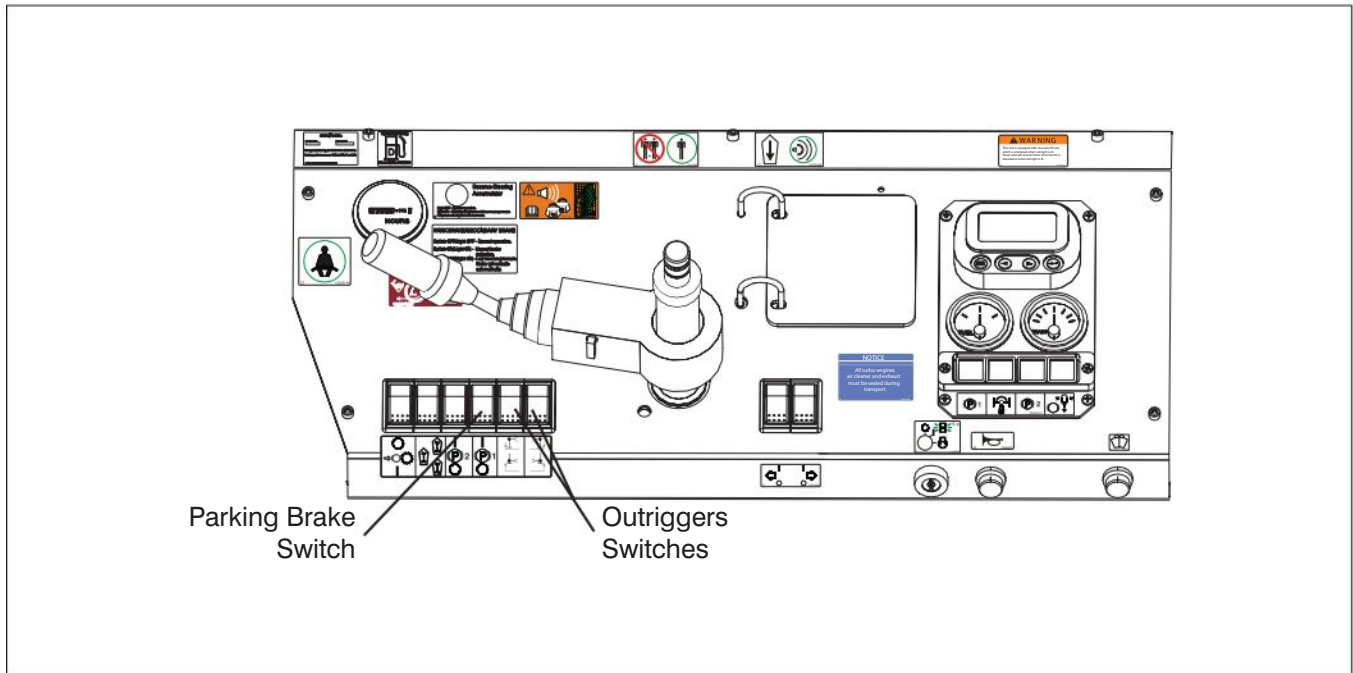

Figure 2-9 Crab Steering

- 14. Steer the telehandler straight ahead until all four wheels are aligned.
- 15. Depress service brake pedal until the telehandler stops.

- 12. Select rocker switch to backward “” position for crab steering.



• **Test Parking Brake**





Refer to [Section 2.10-3](#) for instructions on how to drive on a slope.

1. Ensure path of intended motion is clear.
2. Ensure parking brake switch is off.
3. Drive the telehandler on a slope.
4. Depress service brake pedal slowly until telehandler stops.
5. Select parking brake rocker switch to on position and release service brake pedal.  
**Result:** Parking brake indicator light should turn on and telehandler should not roll

• **Test Outriggers (If Equipped)**



Ensure that there are no personnel or obstructions in test area and that there is sufficient room to test all telehandler functions.

1. Ensure parking brake switch is on.
2. Lower outriggers by depressing and holding rocker switch forward “” continuously.  
**Result:** Outriggers should lower.
3. Raise outriggers by depressing and holding rocker switch backward “” continuously until outriggers are fully raised.  
**Result:** Outriggers should raise up.

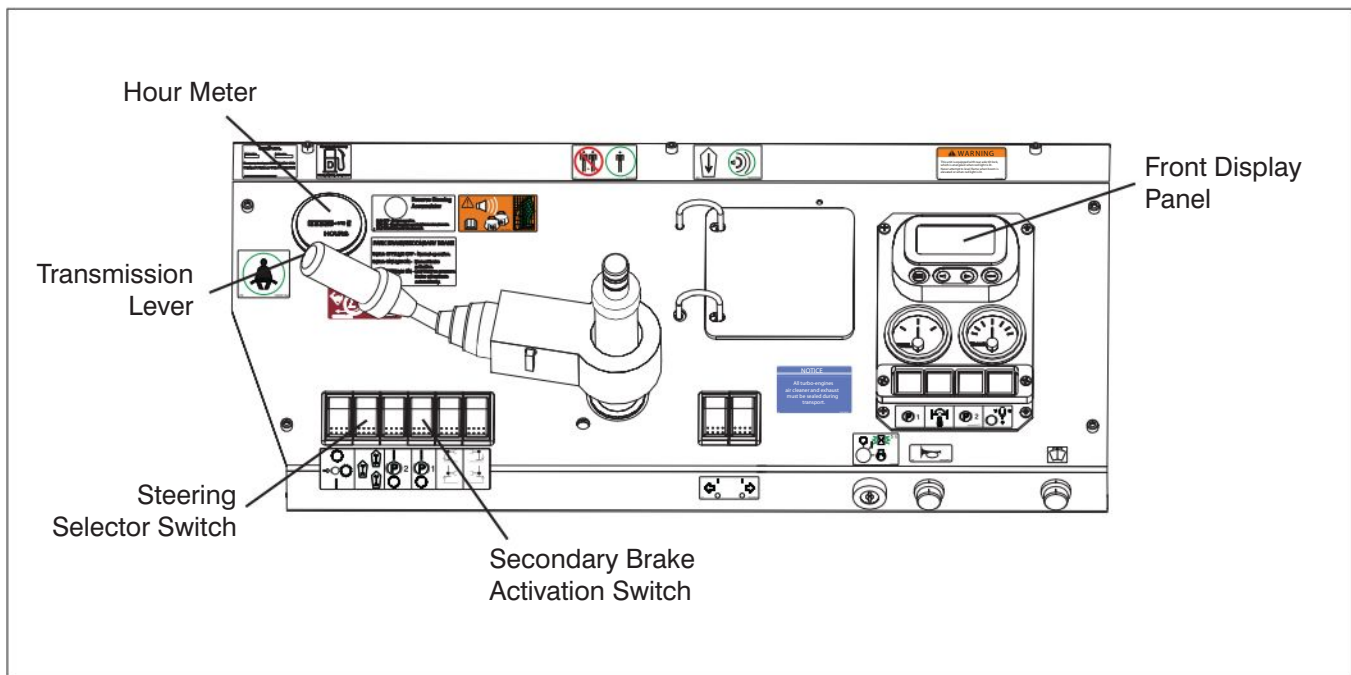

- **Test Optional Reserve Steering (If Equipped)**

1. Start engine and let it run for approximately 2 minutes to ensure proper charging of reserve steering accumulator.

**NOTE**

At initial start up, the red steer light should light momentarily and then go out.

2. Turn off engine.
3. With ignition key switch in "I" on position, turn steering wheel left and right from lock to lock position.  
**Result:** Steering wheel should turn from lock to lock. Reserve steering system is operational.
4. If steering wheel does not fully turn from lock to lock, system must be checked immediately for accumulator charge pressure, system leaks or proper charge solenoid operation.

- **Test Secondary Park Brake (If Equipped)**



**CAUTION**

Refer to Section 2.10-3 for instructions on how to drive on a slope.

1. Ensure path of intended motion is clear.
2. Ensure both park and secondary park brake switches are off.
3. Drive the telehandler on a slope.
4. Depress service brake pedal slowly until telehandler stops.
5. Select secondary brake rocker switch to on position and release service brake pedal.  
**Result:** Secondary park brake indicator light should turn on and telehandler should not roll.



**WARNING**

If the pressure in either of the dual service brake systems fails, charge pressure light will turn on. The Spring Applied Hydraulically Released brake on the system that failed will engage to bring the telehandler to a full stop.

## 2.10 Start Operation

Carefully read and completely understand the Operating Manual and all warnings and instruction labels on the telehandler (refer to labels section).



### WARNING

**DO NOT operate this telehandler without proper authorization and training. Failure to avoid this hazard could result in death or serious injury.**

Before operating this telehandler, perform the following steps:

1. Visual and daily maintenance inspections (see [Section 2.8](#))
2. Function tests (see [Section 2.9](#))
3. Jobsite inspection  
It is the responsibility of the operator to perform a jobsite inspection and avoid the following hazardous situations:
  - holes or drop-offs
  - ditches or soft fills
  - floor obstructions, bumps or debris
  - overhead obstructions
  - electrical cords, hoses and high voltage conductors
  - hazardous locations (see NFPA 505)
  - inadequate surface support to withstand all load forces imposed by the telehandler
  - wind and weather conditions
  - the presence of unauthorized personnel
  - other possible unsafe conditions



### WARNING

**An operator should not use any telehandler that:**

- does not appear to be working properly.
- has been damaged or appears to have worn or missing parts.
- has alterations or modifications not approved by the manufacturer.
- has safety devices which have been altered or disabled.

- has been tagged or blocked out for non-use or repair.

**Failure to avoid these hazards could result in death or serious injury.**

### 2.10-1 Starting the Engine



### WARNING

**Ensure that you maintain three points of contact to mount/dismount the cab.**

1. Enter cab and close door (if equipped).
2. Sit in the driver's seat and fasten seat belt.



### WARNING

**The seat belt must be worn at all times.**

3. Ensure parking brake is on and gear selector in neutral position.
4. To start the engine, turn the ignition switch to on position. The red and amber lights at the top of electronic dash display will illuminate. Once red and amber lights are no longer displayed, and the electronic gauges are visible on the display panel; turn key to start position.
5. Allow engine to idle for 30 seconds until low brake pressure light is off.

## 2.10-2 Driving the Telehandler

**NOTE**

- Be aware of blind spots when operating the telehandler.
- Ensure that there are no personnel or obstructions in the path of travel, including blind spots.
- When traveling at high rate of speed, use front wheel steering mode.
- Slow the telehandler prior to turning.
- Always look at the direction of travel.
- Travel in reverse only at slow rate of speed. Drive only as fast as condition allows.
- Keep attachment or load low (18 - 24 inches) to the ground which gives the best visibility and stability.
- Ensure outriggers (if equipped) are fully raised before driving.

The telehandler is equipped with a powershift transmission. The transmission has forward and reverse gears with speed ranges available in both directions.

1. Depress service brake pedal and move transmission control lever to the desired direction of travel.
2. Release parking brake.
3. Begin selecting first gear and slowly release service brake pedal.
4. Depress accelerator pedal slowly to increase speed. Twist the transmission hand grip to select higher gear until the desired speed is reached.
5. Select appropriate gear for the task being performed. Select lower gear when transporting load, traveling through deep mud, rough terrain, or slopes. Select higher gears only when traveling long distances on smooth terrain without a load.
6. Always bring the telehandler to a complete stop before changing the direction of travel.

## 2.10-3 Driving on Slopes

**DANGER**

**Driving on slopes or inclines can be dangerous and result in forklift tipover or loss of load.**

**WARNING**

- Avoid excessively steep slopes or unstable surfaces. Do not drive across excessively steep slopes under any circumstances.
- Avoid turning on slopes, if at all possible.

1. Keep load low and proceed with caution.
2. Reduce travel speed and downshift to a lower gear before reaching a slope.
3. Ascend and descend slopes with the “heavy end” of the telehandler pointing up the slope.

**NOTE**

When the telehandler has **no load**, the rear is considered the “heavy end.” Travel with the **attachment pointed downhill**.

When the telehandler is **carrying a load**, the front is considered the “heavy end.” Travel with the **attachment pointed uphill**.

4. When driving across a slope, keep frame level.

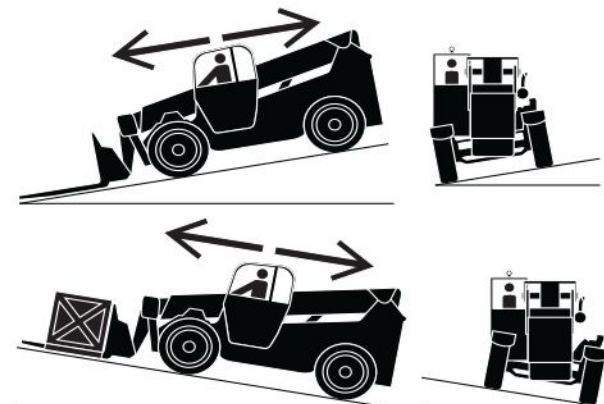

Figure 2-10 Driving on Slopes

**2.10-4 Steering the Telehandler**

Steering is controlled by means of the steering wheel in conjunction with the steering mode selector rocker switch for the type of steering desired.

**Round Steer**

This steer mode is most commonly used on the job site and will give the smallest turn radius available.

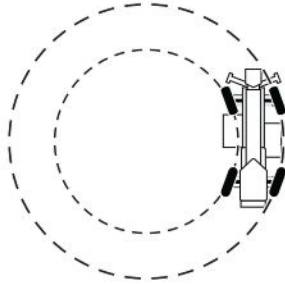

Figure 2-11 Round Steering

**Front Steer**

Two-wheel steer is used during road travel in order to reduce the risk of possible overturn due to over-steering.

**NOTE**

Loss of electrical power will allow front steering only.

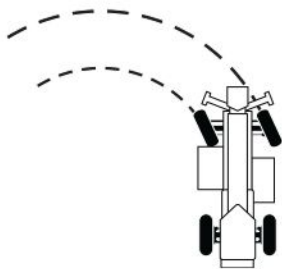

Figure 2-12 Front Steering

**Crab Steer**

The crab steer is used for maneuvering into tight spots.

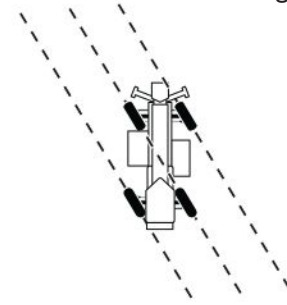

Figure 2-13 Crab Steering

**2.10-5 Leveling the Telehandler**

1. To level frame to the right, move frame level joystick to the right. To level frame to the left, move frame level joystick to the left.
2. Release joystick to stop.

**2.10-6 Raising or Lowering Boom**



**WARNING**

**Ensure that there are no personnel or obstructions and there is sufficient room to perform all telehandler functions.**

1. To raise the boom, pull boom/attachment joystick backward. To lower the boom, push boom/attachment joystick forward.
2. Release joystick to stop.

**2.10-7 Extending or Retracting Boom****WARNING**

**Ensure that there are no personnel or obstructions and there is sufficient room to perform all telehandler functions.**

1. To extend the boom, move the boom/attachment joystick to the right. To retract the boom, move the boom/attachment joystick to the left.
2. Release joystick to stop.

**2.10-8 Handling Loads****WARNING**

- Before commencing operation, familiarize yourself with the capacity charts specific to telehandler model and attachment.
  - Know the weight of the load and the most extreme height and distance required to pick or place the load.
  - Do not lift load on a gradient steeper than 5%.
  - Never position the load behind front face of the tires.
  - Never drive the telehandler with the boom raised.
  - Do not exceed telehandler lift capacity (refer to capacity charts inside operator's cab). Exceeding lift capacity could cause tipover resulting in death or serious injury.
  - When performing lift operation where the operator cannot see load at all times, the operator has to be assisted by a spotter using approved hand signals. (refer to forklift signals label inside cab).
1. Drive as close as possible to load pickup/ placement site.
  2. Place transmission into neutral position. Select parking brake into on position.
  3. Level the frame before lifting the load.
  4. Use outriggers for maximum stability.
  5. Use attachment to pickup/place the load. Refer to procedure [Section 2.14](#) for specific attachment uses.
  6. Retract and keep the attachment/load as low as practical.

### 2.10-9 Parking and Shutting-down the Telehandler



#### **CAUTION**

**Operator should observe the following when parking the telehandler:**

- Avoid parking on slopes or near excavation, ditches or soft fills. If parking on slopes cannot be avoided, ensure telehandler is positioned at a right angle across the slope.
- Avoid parking on roads or highways. If it cannot be avoided, ensure to display warning flags during the day and flares or flashing lights at night.

1. Position telehandler on a firm and level surface.



#### **WARNING**

**Always engage parking brake before leaving the cab.**

2. Engage parking brake.
3. Move transmission shift lever to neutral position.
4. Ensure transmission gear selector is in first gear position.
5. Retract boom fully and position attachment on the ground.
6. Allow engine to idle for 3 to 5 minutes after a full load operation. Failure to do so will result in a fault code on the PowerView display unit.
7. Shut off engine and remove key.



#### **WARNING**

**Ensure that you maintain three points of contact to mount/dismount the cab.**

8. Dismount from telehandler.
9. Chock or block tires to prevent telehandler from rolling.

### 2.11 Refueling Procedure (Diesel Fuel Only)

This section provides the operator with procedure on how to refuel telehandler.

#### **IMPORTANT**

**Before using your telehandler ensure there is enough fuel for expected use.**

- Use extreme caution while refueling telehandler.
- Ensure that engine and all systems are turned off before refueling.
- Refuel the telehandler only in a well ventilated area away from open flame and other sources of ignition, authorized by your employer and supervisor.
- To minimize possible static electricity fires, ensure filler nozzle touches rim of filler opening to aid the dissipation of static electricity.
- Never try to start telehandler if you smell diesel.



#### **WARNING**

**Do not smoke in an area where telehandlers are stored or refueled.**

1. Ensure engine and all systems are turned off.
2. Open fuel cap.
3. Carefully pour diesel fuel into the tank, ensuring no spillage occurs.
4. Close and secure fuel cap.
5. Ensure there are no leaks in fuel system.
6. Wipe up any spilled fuel.
7. Dispose of rags in an approved container.





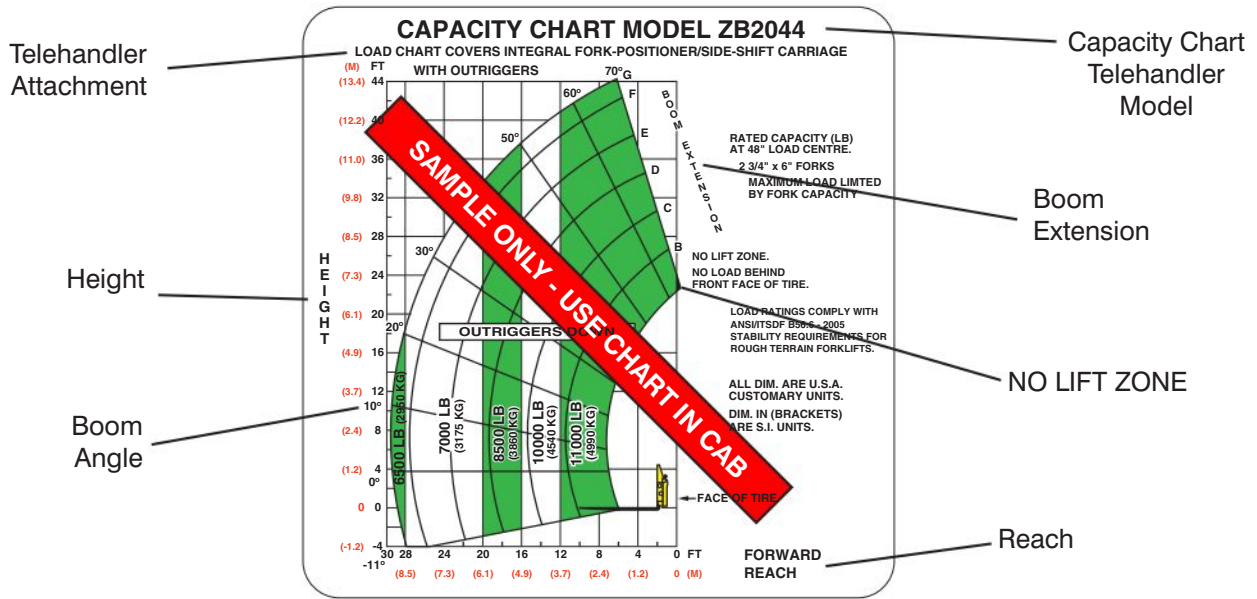

Figure 2-14 Sample Capacity Chart

**2.12 Use of the Capacity Charts**

The capacity charts are located in the operator’s cab. They are used to determine maximum load capacity for telehandler equipped with different attachment combinations.

To properly use a particular capacity chart, the operator must first determine the following:

1. Ensure the capacity chart is for the specific telehandler model and the attachment.
2. Determine the weight of the load to be lifted.
3. Determine the height where the load is to be picked or placed.
4. Determine the reach where the load is to be picked or placed.

5. The maximum capacity is determined by the intersection lines between height and reach on the capacity chart. If the intersection of the lines occurs at a division between capacity zones, the smaller of the two capacity values must be used.

**NOTE**

The weight of the load must be equal to or less than the number in the capacity zone.



**WARNING**

When handling load, ensure that boom extension indicators and boom angle indicator remain within previously determined/calculated capacity zone.

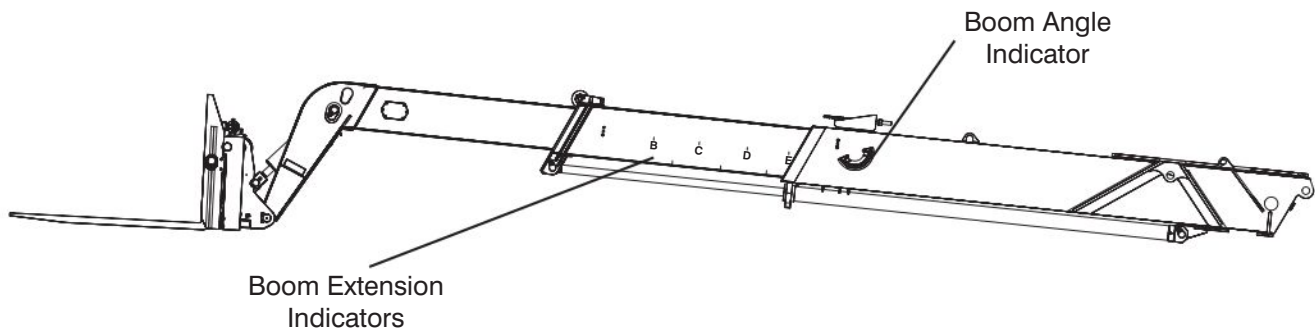

Figure 2-15 Boom Indicators

2.12-1 Examples on Reading the Capacity Chart

The Operator must verify that the capacity chart corresponds with both telehandler and attachment model number.

The following scenarios show various conditions the operator may encounter.

	Load Weight	Reach	Height	Boom Angle	Boom Extension	Capacity	OK to Lift
1	8,250 lb (3,742 kg)	16 ft (4.8 m)	33 ft (10 m)	46°	G	8,500 lb (3,860 kg)	YES
2	9,000 lb (4,082 kg)	18 ft (5.5 m)	22 ft (6.7 m)	34°	F	8,500 lb (3,860 kg)	NO
3	6,500 lb (2,948 kg)	14 ft (4.3 m)	2 ft (0.6 m)	-2°	D	10,000 lb (4,540 kg)	YES
4	13,750 lb (6,236 kg)	6 ft (1.8 m)	37 ft (11.2 m)	65°	F	12,000 lb (5,440 kg)	NO
5	7,925 lb (3,594 kg)	16 ft (4.8 m)	12 ft (3.6 m)	18°	D	8,500 lb (3,860 kg)	YES
6	14,450 lb (6,554 kg)	7 ft (2.1 m)	4 ft (1.2 m)	0°	B	15,000 (6,800 kg)	YES

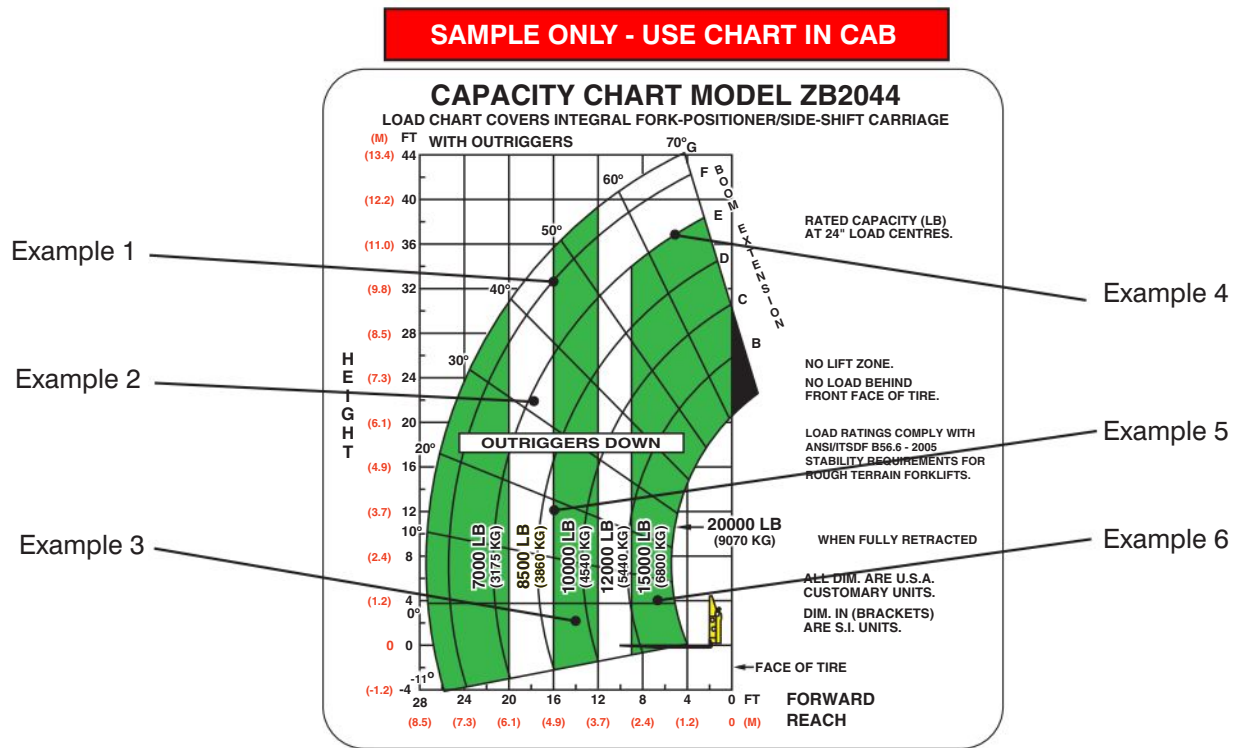

Figure 2-16 Capacity Chart Examples

**NOTE**

This is a sample capacity chart only! DO NOT use this capacity chart. Use chart inside cab.

**NOTE**

If the intersection occurs on a bold line separating the capacity regions, the smaller of the two capacity values must be used.

### 2.13 Attachments Installation

Most of ZB telehandler attachments are “Quick Attach” making the attachment change simple and effortless with no time lost on the job.

#### 2.13-1 Removing Attachments Using the Quick Attach Feature

1. Find an elevated, level surface on which to place the attachment.
2. Move transmission lever to neutral and apply parking brake.
3. Extend and lower boom enough for attachment to rest on the elevated, level surface and lock bar latch located at bottom of subcarriage is fully accessible (see [Figure 2-17-3](#)).
4. Disconnect auxiliary hydraulic oil hoses (if equipped).
5. Remove hitch pin located at end of lock bar then lift carriage pin-stop upward to unlatch and remove lock bar.
6. Lower boom, resting the attachment on the ground and tilt subcarriage forward until subcarriage bar is clear of the hooks (see [Figure 2-17-2](#)).
7. Retract boom, disengaging the attachment (see [Figure 2-17-1](#)).

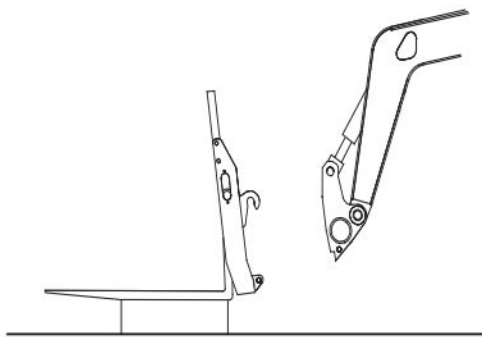

Figure 2-17-1

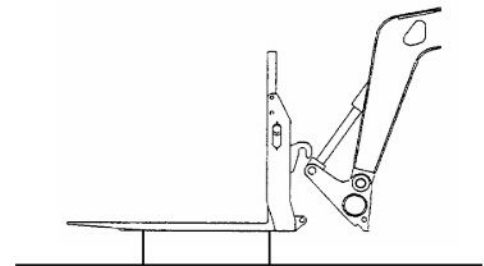

Figure 2-17-2

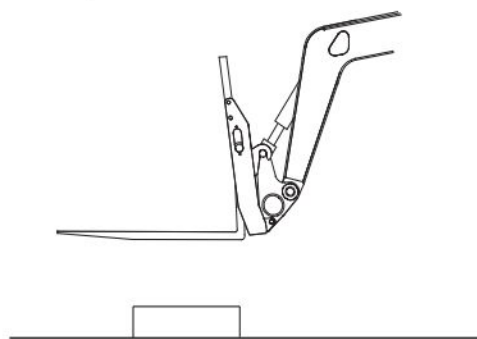

Figure 2-17-3

#### 2.13-2 Installing Attachments Using the Quick Attach Feature

1. Ensure attachment is on a level surface.
2. Move the transmission lever to neutral and apply parking brake.
3. With subcarriage tilted forward, lower and extend boom so that the quick attach bar is positioned under attachment hooks (see [Figure 2-17-2](#)).
4. Engage the attachment by raising the boom and tilting subcarriage backward, so that attachment is just above the ground (see [Figure 2-17-3](#)).
5. Install lock bar then latch carriage pin-stop, and install hitch pin to secure attachment in place.
6. Connect auxiliary hydraulic oil hoses (if equipped).



#### **WARNING**

**Visually check the attachment is correctly coupled and secured to the boom before operating the telehandler.**

2.14 Handling Loads



**WARNING**

- Use the capacity charts inside the cab to assess if the lift is within the capacity of the telehandler.
- ZB2044 model has two capacity charts for each attachment based on deployment of outriggers.
- Ensure that the load center for the load is at or within 24 inches of forks.
- Use a spotter when possible to assist in handling the load. (refer to forklift signals label located inside operator's cab).

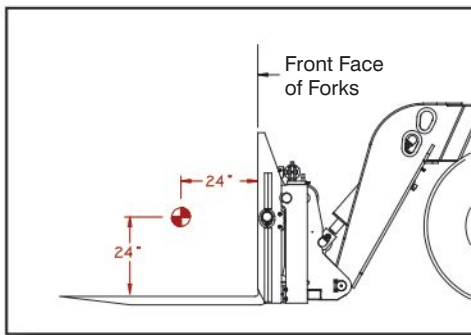

Figure 2-18 Load Center

2.14-1 Handling Loads at Ground Level

Picking up a Load

1. Move the transmission lever to neutral and apply parking brake.
2. Check that the telehandler is level using the level indicator. Adjust frame level if necessary.

3. Ensure the forks are as far apart as possible for the width of the load. This increases the stability of the load and the lift.



4. Approach load slowly with forks straight ahead and perpendicular to the load.



5. Deploy outriggers and insert forks under the load and raise it for 5 to 10 inches.



**WARNING**

**Do not extend boom if lifting maximum rated load; instead, drive into load.**

6. Tilt forks backwards and fully retract the boom
7. Raise outriggers, then check telehandler stability before transporting the load.



Transporting a Load



**WARNING**

**When transporting a load, always travel according to jobsite and weather conditions.**

1. Travel to placement site with load kept as low to the ground as possible.



2. Apply brakes smoothly to bring telehandler to a complete stop before applying parking brakes.

Placing a Load

1. Move the transmission lever to neutral and apply parking brake.
2. Deploy outriggers and check that the telehandler is level using the level indicator. Adjust frame level if necessary.

- Extend boom to the desired reach and tilt forks forward in a horizontal position.



**WARNING**

**Do not extend boom if placing maximum rated load; instead back up from load.**

- Place the load in a horizontal position then lower boom until the load is completely off the forks. Do not apply downward force with the forks.



- Free the forks gradually by lowering and retracting the boom alternately.
- When forks are clear of the load, fully retract the boom.

- Raise outriggers and return to transport position.



**2.14-2 Handling Loads at Variable Heights**

**Picking up a Load**

- Shift transmission lever to neutral and apply parking brake.
- Check that the telehandler is level using the level indicator. Adjust frame level if necessary.
- Ensure the forks are as far apart as possible for the width of the load. This increases the stability of the load and the lift.
- Approach load slowly; raise and extend the boom until the forks are perpendicular to the load.

- Deploy outriggers for maximum stability of telehandler.



- Extend and lower the boom to insert the forks under load and raise it 5 to 10 inches.

- Tilt forks backwards. Fully retract the boom and raise outriggers, then check telehandler stability before transporting the load.



**Placing a Load**

- Shift transmission lever to neutral and apply parking brake.
- Deploy outriggers and check that the telehandler is level using the level indicator. Adjust frame level if necessary.

- Raise and extend boom until the load is perpendicular over placement point.



- Place the load in a horizontal position and lower boom until the load is completely off the forks. Do not apply downward force with the forks.

- Free the forks gradually by raising and retracting the boom alternately.



- When forks are clear of the load, fully retract the boom and raise outriggers, then return to transport position.

### 2.14-3 Adjusting Forks

Adjust the location of both forks using the fork positioner attachment or combination fork positioner/sideshift attachment (if equipped, refer to [Sections 2.14-1 & 2.14-2](#)) or position them manually to suit a pallet pocket spacing as follows:

1. Raise the boom until fork eye is approximately shoulder high.
2. Tilt the attachment forward until the fork pivots on the bar and no longer resting on the attachment's bottom rail ([Figure 2-19](#)). This prevents binding on the bar, thus aiding its repositioning.

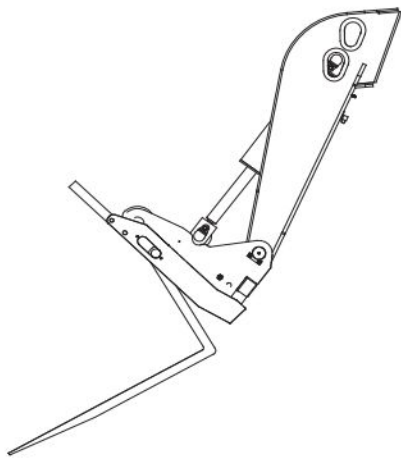

Figure 2-19 Forks Pivoting on the Bar

3. Grasping the fork near its eye, push the fork along the bar until it is in the correct position.



#### CAUTION

Be careful not to pinch fingers between the fork and any portion of the attachment.

### 2.14-4 Changing Forks

The attachment/fork combination is the most frequently used combination. Different loads may require changing forks with different ratings.

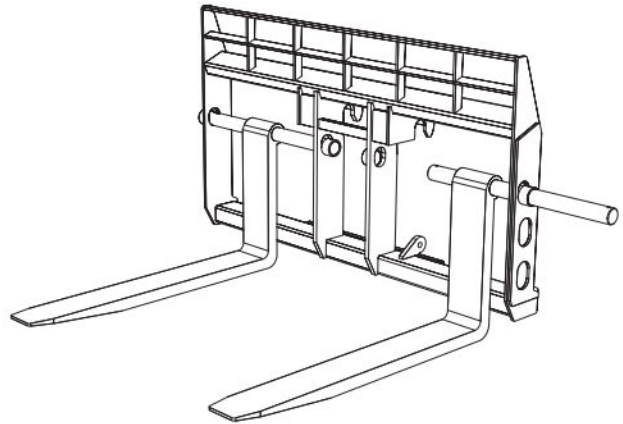

Figure 2-20 Changing Forks

1. Lower the boom with fork contacting the ground until approximately half of the fork float is used up.
2. Remove inner fork bar collars from fork bar.
3. Draw the bar out of the fork eye and attachment side plate, being careful that the fork doesn't fall over, causing possible injury ([Figure 2-20](#)).
4. Reverse steps 1 through 3 to install the replacement fork.

### 2.14-5 Slinging Loads



#### CAUTION

Sling loads from appropriate attachment to the jib boom or a tilted fork **ONLY**.

1. Slinging of loads must only be performed following a complete risk assessment by a qualified person regarding the rigging and guiding of any such load.
2. The rated capacity of the unit and attachment at the sling position must not be exceeded. The sling must be in good repair and restrained from movement at all times.

**2.15 Optional Attachments**

The SKYJACK ZB series telehandler is designed to accept a variety of optional “Quick Attach” attachments aside from regular fork carriage attachment. Ensure to use appropriate attachment capacity chart.

**2.15-1 Fork Positioner Attachment**

Fork positioner attachment allows operators to accurately and easily adjust the distance between forks to suit different size pallets.

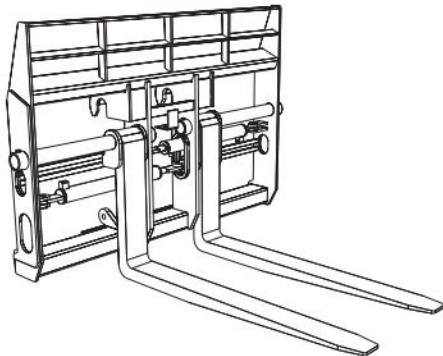









Figure 2-21 Fork Positioner Attachment

**Installation Procedure:**

1. Remove fork attachment or other attachment from boom and connect fork positioner attachment (refer to Section 2.13).
2. Connect auxiliary hydraulic hoses.

**Operation:**

1. Depress and hold right thumb button “” and move joystick “” forward to shift right fork to the right. Depress and hold right thumb button “” and move joystick backward “” to shift right fork to the left.
2. Depress and hold left thumb button “” and move joystick forward “” to shift left fork to the left. Depress and hold left thumb button “” and move joystick “” backward to shift left fork to the right.
3. Handle load the same as regular fork attachment (refer to Section 2.13).

**2.15-2 Combination Fork Positioner/Sideshift Attachment**

The Combination fork positioner/sideshift attachment allows the adjustment of distance between the forks as well as the movement of entire carriage assembly to either left or right. This attachment is useful when handling different size pallets that need special adjustment of both forks and carriage.

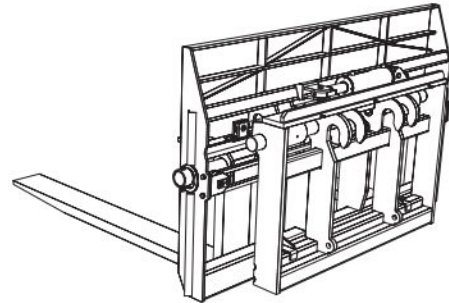



Figure 2-22 Combination Fork Positioner/Sideshift Attachment

**Installation Procedure:**

1. Remove fork attachment or other attachment from boom and connect combination fork positioner/sideshift attachment (refer to Section 2.13).
2. Connect auxiliary hydraulic hoses to diverter valve on yoke.

**Operation:**

1. Shift carriage assembly to the right by moving joystick forward. Shift carriage assembly to the left by moving joystick backward.
2. Adjust the distance between forks by pressing and holding thumb buttons and moving joystick either forward or backward.

 = left fork

 = in

 = right fork

 = out

3. Handle load the same as regular fork attachment (refer to Section 2.14).



### 2.15-3 Bridge Stripper Attachment

The bridge stripper attachment is used to strip falsework or temporary support structures at bridge-construction sites.

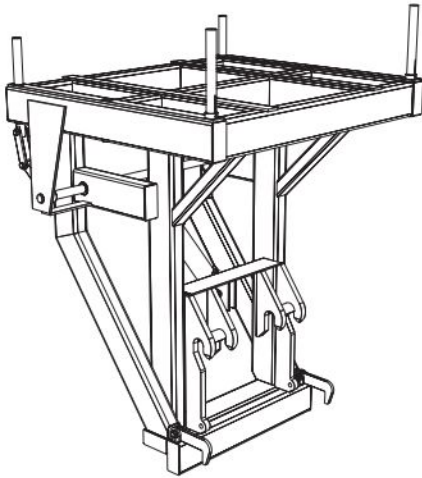



Figure 2-23 Bridge Stripper Attachment

#### Installation Procedure:

1. Remove fork attachment or other attachment from boom and install bridge stripper attachment (refer to [Section 2.13](#)).
2. Connect auxiliary hydraulic hoses to attachment.

#### Operation:

1. Raise and extend boom to position stripper under load.
2. Move rear joystick “” backward to extend stripper pins.
3. Rest load on stripper then lower and retract boom to appropriate height.
4. Travel to placement point with load kept as low to the ground as possible.
5. Move rear joystick “” forward to retract stripper pins and tilt attachment forward to unload.

### 2.15-4 Pipe and Pole Grapppler

Pipe and pole grapppler is intended for handling single and multiple pipes.

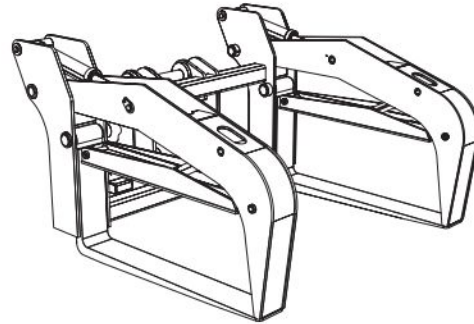







Figure 2-24 Pipe and Pole Grapppler

#### Installation Procedure:

1. Remove fork attachment or other attachment from boom and install pipe and pole grapppler attachment (refer to [Section 2.13](#)).
2. Connect auxiliary hydraulic hoses to attachment.

#### Operation:

1. Approach load with grapppler's clamps open.
2. Insert forks under load and lift it, then tilt grapppler backward so that load will not fall causing possible injury.
3. Close primary clamps by pressing and holding left thumb button “” and moving the joystick forward “”. With joystick pushed forward, press and hold right thumb button “” to close secondary clamps and secure the load in place.
4. Raise or lower boom to appropriate height and transport load with caution to placement site.
5. Position load carefully over placement point. Open secondary clamps by pressing and holding right thumb button “” while moving joystick backward “”. With joystick pulled backward, press and hold the left thumb button “” to open primary clamps.

**2.15-5 Pipe and Pole Handler**

Pipe and pole handler allows the operator to position, remove and stack support posts used in the construction of bridges and highways. It can also handle other pipes and/or poles, and vertically position them.

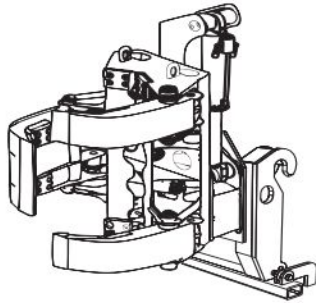







Figure 2-25 Pipe and Pole Handler

**Installation Procedure:**

1. Remove fork attachment or other attachment from boom and install pipe and pole handler attachment (refer to [Section 2.13](#)).
2. Connect auxiliary hydraulic hoses to attachment.
3. Route electrical harness supplied with attachment up through centre of sub-carriage and between tilt cylinders, ensuring it will not be damaged during operation.
4. Remove top electrical connector on 3-way diverter valve and attach to electrical connector of harness supplied with attachment.
5. Tighten connector screw and confirm the functionality of the handler.

**Operation:**

1. Approach load with handler’s clamps open.
2. Position handler so that load is in the center of clamps.
3. Close clamps by moving joystick “” rearward and transport load to placement site.
4. Press and hold “” the left thumb button and move joystick “” rearward to rotate the pole and pipe handler clockwise.

5. Press and hold “” the left thumb button and move joystick “” forward to rotate pole and pipe handler counter-clockwise.
6. Position load carefully over placement point and open the clamps by moving the joystick “” forward .

**2.15-6 Hydraulic Winch**

Hydraulic winch is used to raise and lower loads vertically such as lowering equipment into a shaft with limited access.

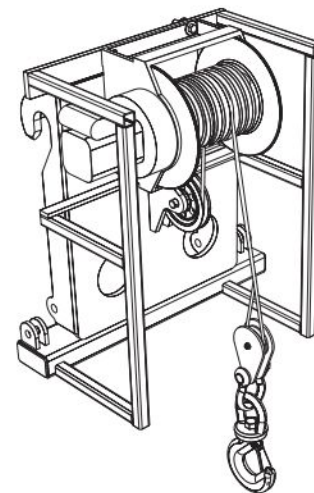

Figure 2-26 Hydraulic Winch Attachment

**Installation Procedure:**

1. Remove fork attachment or other attachment from boom and install winch attachment (refer to [Section 2.13](#)).
2. Connect auxiliary hydraulic hoses to attachment.



**WARNING**

**Only qualified service personnel should install hydraulic winch.**

**Operation:**

1. Attach load to winch hook using proper cables or chains and move joystick “” backward to winch up the load.

2. While helpers guide the load with tag lines, position load at placement point.
3. To winch down the load, move joystick “” forward until load is rested safely on placement point. Release cables or chains from winch hook.

### 2.15-7 Jib Boom Attachment (5-ft)

A jib boom is an attachment with a hook or jib eye load connection. This connection is used for extending the forward reach and lift height of the telehandler at the expense of load capacity.

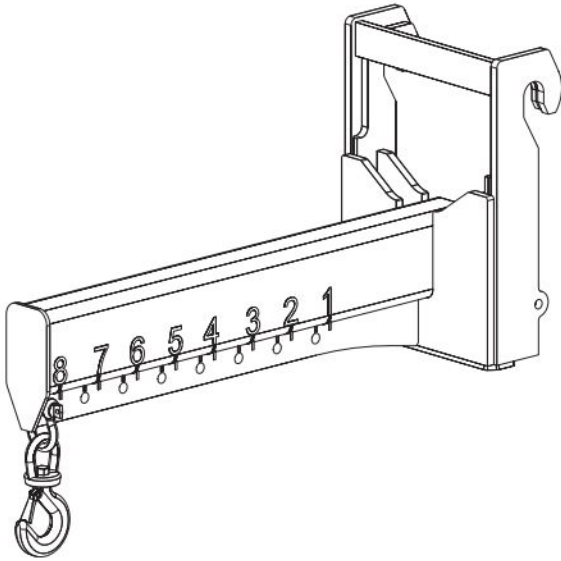

Figure 2-27 Jib Boom Attachment (5 ft.)

#### Installation Procedure:

1. Remove fork attachment or other attachment from boom and connect jib boom attachment (refer to [Section 2.13](#)).



#### WARNING

**Mounting jib boom changes center of gravity of telehandler. Consult capacity charts specific to attachment before handling loads.**

#### Operation:

1. Using boom controller, adjust jib boom over the center of the load.
2. Attach load to the pintle hook using sufficient chains/cables.

3. While helpers guide the load, position load at placement point.

### 2.15-8 Light-material Bucket

A material bucket has a high back and straight sides for cutting into piles of low density materials. This attachment is used for light material handling such as snow removal or transporting of grains and other loose materials. Material buckets are not meant for excavation as high twisting loads can damage the boom.

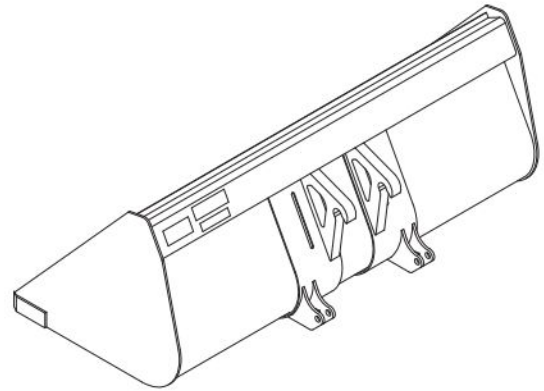

Figure 2-28 Light-material Bucket

#### Installation Procedure:

1. Remove fork attachment or other attachment from boom and connect material bucket (refer to [Section 2.13](#)).

#### Operation:

1. Raise or lower boom to appropriate height for loading material from stockpile.
2. Position telehandler so that it is perpendicular to the stockpile. Drive slowly and smoothly into pile to load bucket.
3. Using the optional attachment joystick, tilt bucket backwards enough to retain the load. Back away from pile.
4. Drive to the unloading point and keep bucket approximately 4 feet above the ground.
5. Tilt bucket forward to dump load.

**2.15-9 Coil Boom**

Coil boom is used to handle steel coil. This attachment is similar to carpet poles but has a larger diameter and a shorter boom.

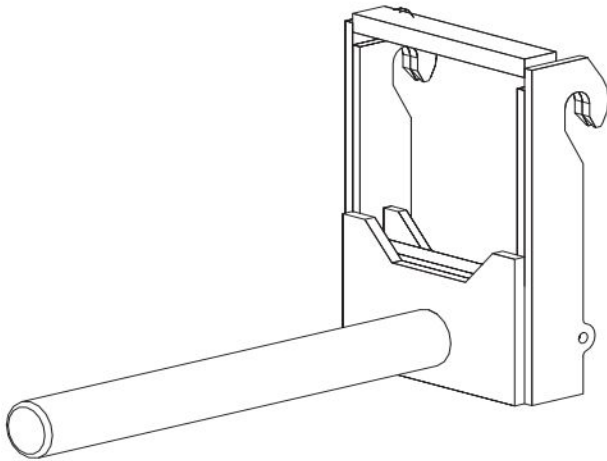

Figure 2-29 Coil Boom Attachment

**Installation Procedure:**

1. Remove fork attachment or other attachment from boom and install coil boom attachment (refer to [Section 2.13](#)).

**Operation:**

1. Approach load with boom positioned to the middle of coil material to be lifted.
2. Insert boom and lift load, then tilt carriage backward so that load will not fall causing possible injury.
3. Raise boom to appropriate height and transport load with caution to placement site.
4. Lower and retract boom to place load carefully.

**2.15-10 Third-Party Attachments & Platforms for Elevating Personnel**

Skyjack’s Zoom Boom Rough Terrain Forklifts (RTFL), are designed to lift and/or handle industrial products by means of various attachments. Skyjack does not certify the design of third-party attachments, including platforms for elevating personnel. Skyjack does not assume any responsibility or liability for damages resulting from the use of third-party attachments on any of its Zoom Boom RTFL’s.

- 2.15-10-1** It is permissible to install and utilize third-party attachments, provided they do not elevate personnel and the following conditions are met:



**The combined mass of the attachment and load shall not exceed that of the RTFL load chart for the applicable load center. The rated capacity of the attachment shall not be exceeded.**

**IMPORTANT**

**In addition to the RTFL operating instructions, all instructions provided by the manufacturer of the attachment must be followed and any additional requirements of local authorities should also be followed.**

**Attachments shall be designed and constructed according to CSA B335 and ANSI/ITSDF B56.6, including markings identifying the combined RTFL and attachment weight, and the RTFL capacity with the attachment at maximum elevation and load laterally centered.**

**The attachment must be securely attached to the RTFL, per the attachment manufacturer’s instructions.**

**Prior to using the attachment on each shift, the RTFL operator must visually examine the attachment for structural integrity and perform the daily inspection and function tests on the RTFL. Any equipment defects must be repaired before the attachment or RTFL can be used.**



### 2.16 Loading and Transporting

Know all national, state/provincial and local rules which apply to transporting of telehandlers.

Only qualified personnel shall operate machinery during loading and transporting.

Be sure vehicle capacity and loading equipment hoists, chains, straps, etc., are sufficient to withstand maximum telehandler weight.

The transport vehicle must be parked on a level surface and must be secured to prevent rolling while telehandler is being loaded or unloaded.

#### **IMPORTANT**

**All turbo-engines air cleaner and exhaust must be sealed during transport.**

#### 2.16-1 Loading and Tie-down

1. Ensure telehandler is level prior to loading.
2. Fully lower and retract boom and raise outriggers (if equipped).
3. Ensure ramps are correctly positioned.

4. Using a spotter, carefully drive telehandler onto the transporting vehicle.
5. Once telehandler is loaded, apply parking brake and rest the attachment flat on the vehicle platform.
6. Move all controls to neutral position.
7. Turn key switch to "O" off position and remove key before transporting.
8. Chock telehandler wheels (if necessary).
9. Remove all loose items.
10. Anchor down telehandler to transport surface using tie-down points and secure the forks to the platform using sufficient straps. (See diagram below).



#### **WARNING**

**Inspect telehandler for loose or unsecured items.**

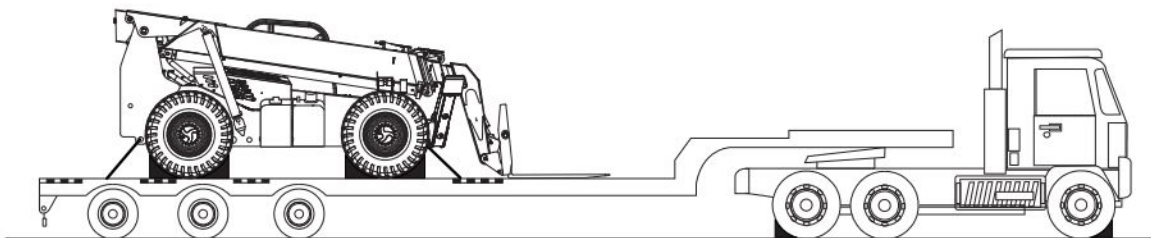
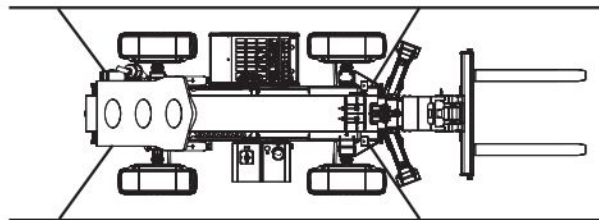

Fig 2-30 Tie-down points

## 2.16-2 Towing the Telehandler

**IMPORTANT**

- Use this procedure only to remove telehandler from mud or other places where it cannot move under its own power. When possible, repair telehandler on site.
  - Always chock wheels of the disabled telehandler to prevent accidental movement while preparing for towing. This is especially important if the failure occurs on an incline.
  - Before towing, ensure there are no obstructions around or between telehandler and towing vehicle.
  - The spotter must maintain a safe distance and must always be visible to the operator inside telehandler's cab.
  - Ensure the towing vehicle, chains, tow bar, etc., are suitable for the job. The telehandler weight is stamped on the serial number nameplate.
1. Lower or raise boom and outriggers (if equipped) enough so that front tie-down points are fully accessible.
  2. Carefully fasten tow chains to tie-down points on either front or rear of telehandler frame.

3. Remove chocks from wheels.
4. Enter cab and fasten seatbelt.
5. Ensure transmission gear selector is in 'neutral' and the transmission lever neutral lock switch is in the 'N' neutral position.
6. Start the engine.
7. Release park brake.
8. Start towing the telehandler while operating the steering and brakes.
9. Move telehandler to a compact level surface.
10. Apply park brake.
11. Turn off engine and remove key from ignition switch.

**WARNING**

**Ensure that you maintain three points of contact to mount/dismount the cab.**

12. Dismount from telehandler.
13. Chock or block wheels to prevent telehandler from rolling.

**CAUTION**

**Bad traction can cause telehandler or towing vehicle to slide. Grades can require additional distance to stop the telehandler. Be careful if traction conditions are bad or the machine on an incline.**

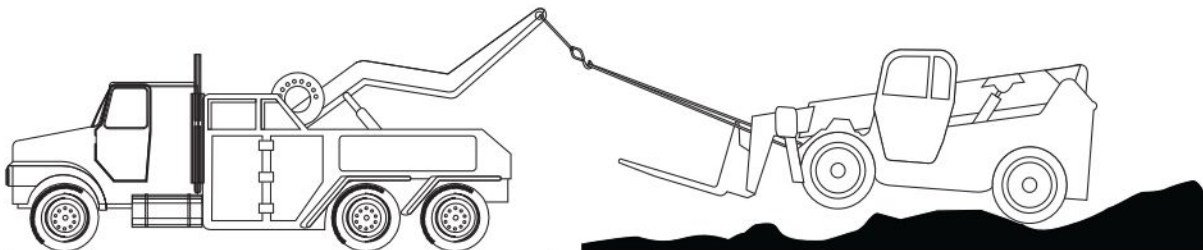

Fig 2-31 Towing the telehandler from front tie-down points

### 2.17 Coolant Level Maintenance

Refer to this section for instructions on maintaining correct coolant levels.



#### 2.17-1 Radiator Fill Maintenance



**WARNING**

**Pressurized fluid present in radiator.  
Never open radiator cap when hot.**

1. Open engine vent. Leave vent open during radiator fill. Refer to [Figure 2-32](#).

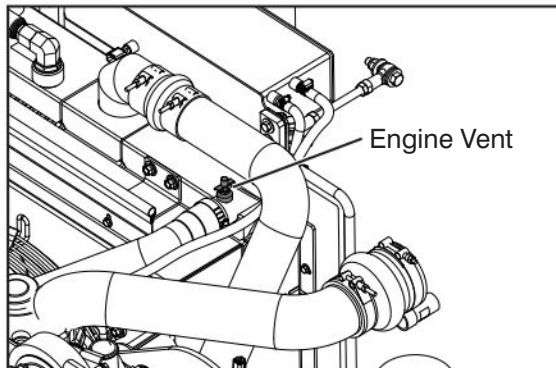

Figure 2-32 Engine Vent Location

2. Remove radiator cap.
3. Fill radiator through the radiator neck until a solid, airless stream of coolant flows out of the engine vent, then close the engine vent.

**NOTE**

When filling the radiator, do not exceed 3GPM fill rate.

4. Fill radiator completely through the reserve tank filler neck, until coolant is visible through the sight glass. See [Figure 2-33](#).

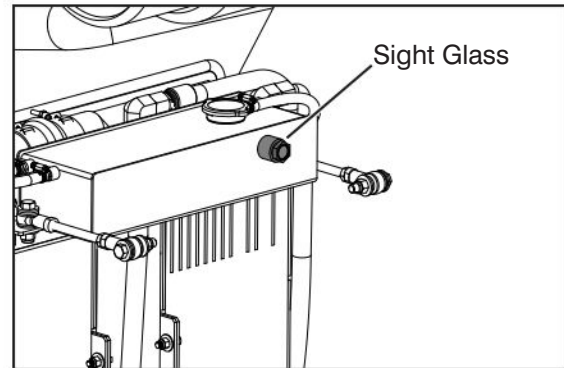

Figure 2-33 Sight Glass Location

5. Run the engine for 25 minutes without radiator cap to achieve operating temperature. Shut down the engine.
6. Check coolant level at the sight glass. Refill until coolant is visible through the sight glass, if necessary.
7. Install radiator cap.

**NOTE**

Additional coolant may be required in the top tank after a few operational cycles.





2.18 Tables

Table 2.1 Standard and Optional Equipment

MODEL	ZB2044
<b>STANDARD EQUIPMENT</b>	
Pilot-operated joystick boom & frame level controls	✓
4 wheel power steering	✓
Electronic dash and full gauge instrumentation	✓
Hydraulic frame leveling	✓
Front Wheel Steering	✓
Round Steering	✓
Crab Steering	✓
Automatic self-leveling forks	✓
Dual batteries	✓
Rear axle lock system	✓
Load capacity charts	✓
Engine air intake grid heater	✓
Service and park brake activated transmission disconnect	✓
ROPS/FOPS operator compartment	✓
4 wheel drive	✓
External rear view mirrors	✓
Automatically activated S.A.H.R. parking brake	✓
Electric horn and reverse warning alarm	✓
Anti-skid floor and steps	✓
Quick disconnect carriage	✓
<b>OPTIONAL EQUIPMENT</b>	
Various carriage and fork sizes	✓
Outriggers	Standard
Foam-filled tires	✓
Turn signals/lights	✓
Working lights	✓
Flashing beacon	✓
Auxiliary hydraulics	✓
Fork positioner	✓
Forkshift/Sideshift Carriage	✓
Jib boom	✓
Coil boom	✓
Enclosed operator cab	✓
Fenders	✓
Air conditioning	✓
Pipe and pole clamp	✓
Pipe and pole grappler	✓
Mine code specification	✓
Positive Air Shutoff	✓

237D

Table 2.2 Specifications and Features

MODEL	ZB2044
<b>Engine</b>	
Type	Cummins QSB4.5
Max RPM	2500 rpm
Horsepower @ 2300 RPM	168 HP
Horsepower @ 2500 RPM	163 HP
Fuel type	Diesel
<b>Transmission</b>	
Type	DANA T32000
Speeds forward	3
Speeds Reverse	3
Top Speed	20.5 mph (33 km/h)
<b>Gear Ratios</b>	
1st Gear	4.64 : 1
2nd Gear	2.23 : 1
3rd Gear	0.82 : 1
<b>Electrical</b>	
System voltage	12 volts negative ground
<b>Standard Batteries</b>	
Type	HP-31E
Quantity	2
Cranking amperes @ 0°F (-17°C)	725 A
Total cranking amps @ 0°F (-17°C)	1450 A
Cranking amperes @ 32°F (0°C)	1100 A
Reserve capacity	180 minutes
<b>Dimensions</b>	
Overall length (less forks)	243 in (617 cm)
Overall width	102 in (259 cm)
Overall Height	108 in (274 cm)
Curb weight (standard machine with open cab)	45,000 lbs. (20,000 kg)
Maximum capacity	20,000 lbs. (9,071 Kg)
Wheelbase	138 in (350 cm)
Round steer turning Radius (inside)	220 in (559 cm)
<b>Boom</b>	
Number of sections	3
Maximum lift height	44 ft. 10 in (1366 cm)
Maximum forward reach	27 ft 5 in (835 cm)
Standard Forks	2 <sup>3</sup> / <sub>4</sub> x 6 x 60 in (6.9 x 15.2 x 152.4 cm)
Carriage rollback	19°
Carriage forward tilt	80°
<b>Operating Times</b>	
Boom extend (at max. boom angle)	13 seconds
Boom retract (at max. boom angle)	9.5 seconds
Boom raise*	19 seconds
Boom lower*	20 seconds
Carriage roll forward	12 seconds
Carriage roll back	12 seconds
Frame level right (stop to stop) **	15 - 20 seconds
Frame level left (stop to stop) **	15 - 20 seconds

238-C

\* Measured with boom fully retracted.

\*\* Under no circumstances should the frame level cycle take less than 15 seconds to complete in either direction.

Table 2.3 Tire/Wheel Specifications

Standard Tires	
Tire Size	17.50 - 25
Pressure	90 psi
Tire Ply Rating	16 PR
Wheel Nuts Torque	450 - 500 ft.lb

239A

**WARNING**

Intermixing tires of different types or using tires of types other than those originally supplied with this equipment can adversely affect stability. Therefore, replace tires only with the exact original Skyjack-approved type. Failure to operate with matched approved tires in good condition may result in death or serious injury.

**IMPORTANT**

For proper function of each axle differential, all four wheels must have same tire size installed at all times. Failure to comply with this requirement will reduce the life of the differentials and reduce overall mobility of telehandler.

Table 2.4 Recommended Fluids/Lubrication

	MODEL	ZB2044
Engine	Fuel Type	Diesel
	Fuel Tank Capacity	49 gal (185 L)
	Recommended Oil Type	15W40 CC/SF
	Coolant Type	60/40 Ethylene glycol/distilled water
Transmission	Type	ATF Dexron III
	Capacity	6.3 gal (24 L)
Axles	Differential	SAE 80W-90 GL-5
	Planetary Wheel Ends	
Hydraulic Oil	Type	Anti-wear ISO Gr. 32
	Tank Capacity	55 gal (208 L)
Grease	Boom Slide Bearings	Sunaplex 992 E.P. 2
	General Greasing	Multi Purpose E.P.

240C

**General Maintenance**

Before attempting any repair work, turn ignition switch to off position. Preventive maintenance is the easiest and least expensive type of maintenance.

**Table 2.5 Maintenance and Inspection Schedule**

Frequency	Daily	Weekly	Quarterly or 250 hours	Annually or 1000 hours
<b>Visual and Daily Maintenance Inspections</b>				
Labels	A			
Electrical	A			
Safety Switches	A			
Mirrors	A			
Hydraulic	A			
Cylinders	A			
Frame				
Wheel/Tire Assembly	A			
Drive Axle	A			
Steer Cylinder Assembly	A			
Steer Linkage	A			
Batteries	A			
Engine Air Filter	A			
Engine Coolant	A			
Muffler and Exhaust	A			
Engine Compartment	A			
Engine Oil Level	A			
Engine Coolant Level	A			
Fuel Leaks	A			
Hydraulic Pump	A			
Belts	A			
Fuel Tank	A			
Hydraulic Tank	A			
Hydraulic Oil	A			
Hydraulic Return Filter	A			
Boom				
Slide Pads	A			
Chain	A			
Boom Angle Indicator	A			
Proximity Sensor	A			
Transmission				
Lifting Attachment	A			
Grease Fittings				
Grease Fittings on Frame		B		
Grease Fittings on Boom Assembly		B		
Operator's Cab				
ROPS/FOPS	A			
Seat	A			
Pedals	A			
Manual	A			
Operator's Cab Controls	A			

C\* †

Frequency	Daily	Weekly	Quarterly or 250 hours	Annually or 1000 hours
<b>Function Tests</b>				
Operator's Cab Controls				
Test Horn	A			
Test Reverse Alarm	A			
Test Lights	A			
Test Boom and Attachment Functions	A			
Test Frame Leveling and Level Indicator	A			
Test Frame Level Lock	A			
Test Accelerator Pedal	A			
Test Driving and Service Brake Functions	A			
Test Steering	A			
Test Parking Brake	A			
Test Outriggers (if equipped)	A			

C\*†

220D

A - Perform Visual and Daily Maintenance Inspections & Functions Test. Refer to Section 2.7 and Section 2.8 of this manual.

B - Perform Visual and Weekly Maintenance Inspections & Functions Test. Refer to Section 2.7 and Section 2.8 of this manual.

C - Perform Scheduled Maintenance Inspection. Refer to Service manual.

\* - Maintenance must be performed only by trained and competent personnel who are familiar with mechanical procedures.

† - Refer to Skyjack's website @ [www.skyjack.com](http://www.skyjack.com) for latest service bulletins prior to performing quarterly or yearly inspection.

Table 2.6 Operator's Checklist



Serial Number: \_\_\_\_\_  
 Model: \_\_\_\_\_  
 Hourmeter Reading: \_\_\_\_\_  
 Date: \_\_\_\_\_  
 Time: \_\_\_\_\_

Operator's Name (Printed): \_\_\_\_\_  
 Operator's Signature: \_\_\_\_\_

Each item shall be inspected using the appropriate section of the Skyjack operating manual. As each item is inspected, check the appropriate box.

**P** - PASS  
**F** - FAIL  
**R** - REPAIRED  
**NA** - NOT APPLICABLE

DAILY  
 FREQUENTLY  
 QUARTERLY  
 ANNUALLY

	N/A	P	F	R
<b>Visual and Daily Maintenance Inspections</b>				
<b>Labels</b>				
<b>Electrical</b>				
<b>Safety Switches</b>				
<b>Mirrors</b>				
<b>Hydraulic</b>				
<b>Cylinders</b>				
<b>Frame</b>				
Wheel/Tire Assembly				
Drive Axle				
Steer Cylinder Assembly				
Steer Linkage				
Batteries				
Engine Air Filter				
Engine Coolant				
Muffler and Exhaust				
<b>Engine Compartment</b>				
Engine Oil Level				
Fuel Leaks				
Hydraulic Pump				
Belts				
Fuel Tank				
Hydraulic Tank				
Hydraulic Oil				
Hydraulic Return Filter				
<b>Boom</b>				
Slide Pads				
Chain				
Boom Angle Indicator				
Proximity Sensor				
<b>Transmission</b>				
<b>Lifting Attachment</b>				
<b>Grease Fittings</b>				
Grease Fittings on Frame				
Grease Fittings on Boom Assembly				
<b>Operator's Cab</b>				
ROPS/FOPS				
Seat				
Pedals				
Manual				
Operator's Cab Controls				

	N/A	P	F	R
<b>Function Tests</b>				
<b>Operator's Cab Controls</b>				
Test Horn				
Test Reverse Alarm				
Test Positive Air Shutoff (If Equipped)				
Test Lights				
Test Boom and Attachment Functions				
Test Frame Levelling and Level Indicator				
Test Accelerator Pedal				
Test Driving and Service Brake Functions				
Test Steering				
Test Parking Brake				
Test Outriggers (If Equipped)				





222C

**Note:**  
 Make a copy of this page or visit the Skyjack web site:  
[www.skyjack.com](http://www.skyjack.com) for a printable copy.

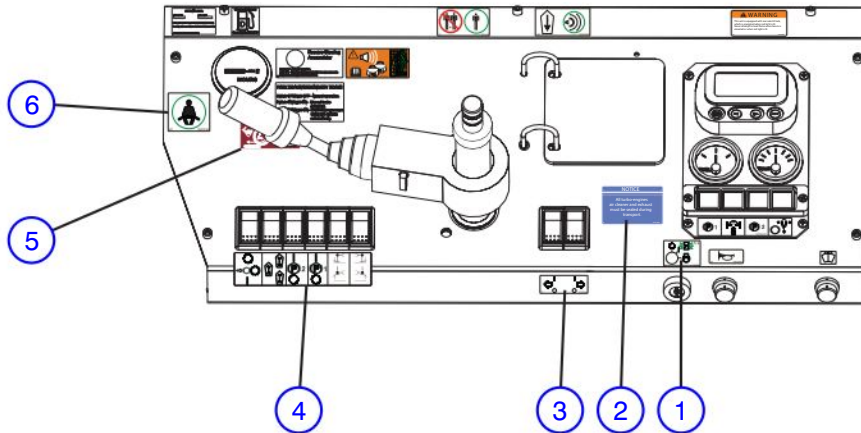
Labels - Model ZB2044

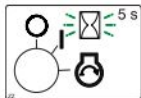
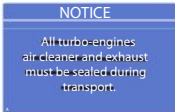
Operator's Console

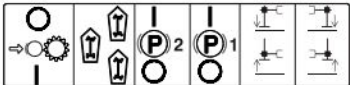





No.	Label Pictorial	Description
1		<p><b>Starting Procedure</b></p> <p>Turn key to ON, wait for engine display to initialize, wait for “Wait To Start” indicator to turn off, then start engine.</p>
2		<p><b>Transportation Reminder</b></p> <p>Ensure engine, air cleaner, and exhaust are sealed during transportation.</p>
3		<p><b>Turn Signals*</b></p> <p>Indicates left and right turn signals. * If equipped.</p>
4		<p><b>Function Switches</b></p> <p>Use these switches to select steering mode, set parking brake, secondary brake* and deploy outriggers. * If equipped</p>
5		<p><b>Positive Air Shutoff*</b></p> <p>Use this switch to trigger the positive air shutoff valve. * If equipped</p>
6		<p><b>Danger! Seat Belt Warning</b></p> <p>Do not operate telehandler without seat belt fastened.</p>

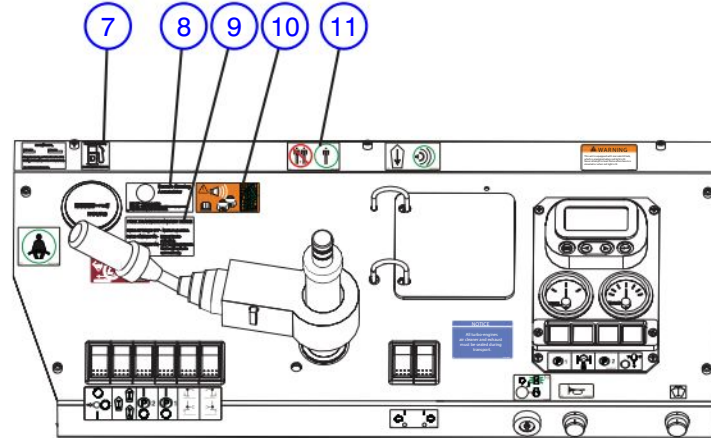

Labels - Model ZB2044

Operator's Console (Continued)

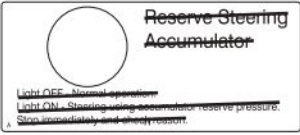
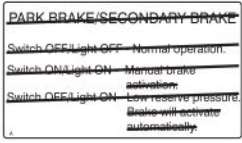
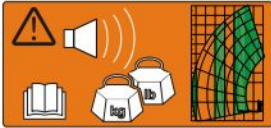



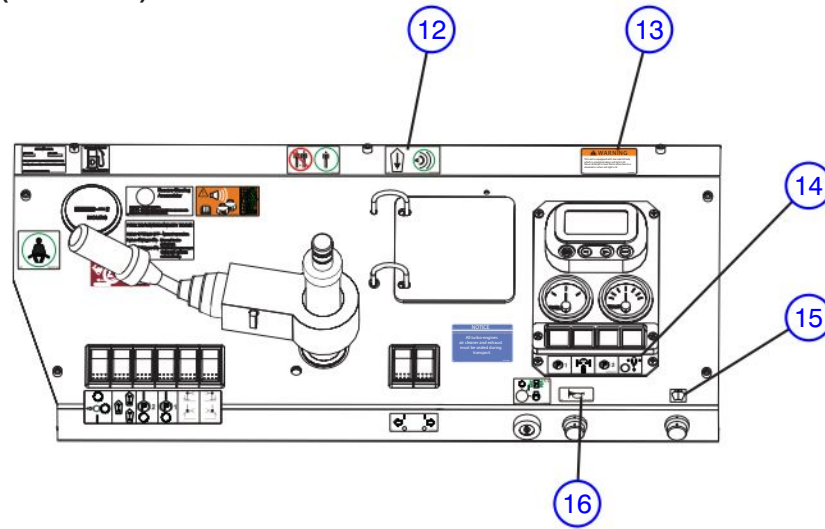

No.	Label Pictorial	Description
7		<p><b>Ultra Low Sulfur Diesel Fuel*</b></p> <p>Refill fuel tank with ultra low sulfur diesel fuel only. *If equipped</p>
8		<p><b>Reserve Steering Accumulator*</b></p> <p>Indicates when steering is using accumulator reserve pressure. * If equipped.</p>
9		<p><b>Brake Information*</b></p> <p>Describes manual and low reserve pressure brake information. * If equipped</p>
10		<p><b>Lift Circuit Overload Alarm*</b></p> <p>Buzzer activates when load is above machine capacity. Load must not exceed values on capacity chart. * If equipped</p>
11		<p><b>No Riders Warning</b></p> <p>Absolutely no riders on telehandler.</p>

Labels - Model ZB2044

Operator's Console (Continued)

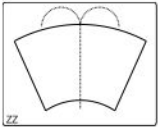





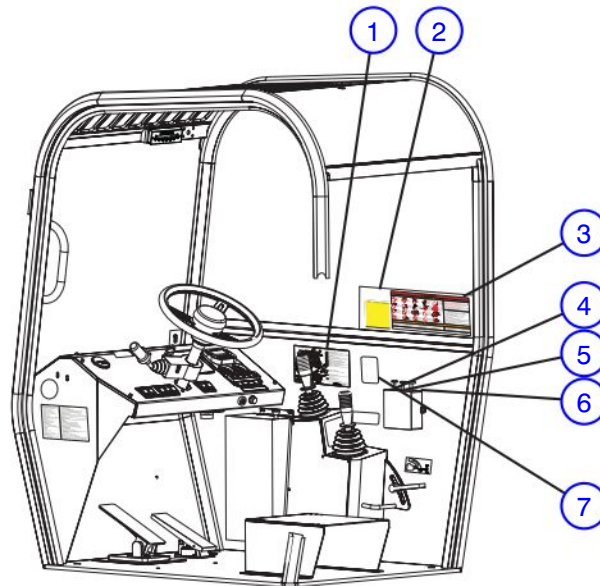

No.	Label Pictorial	Description
12		<p><b>Back-up Alarm Warning</b></p> <p>Telehandler is equipped with a back-up alarm.</p>
13		<p><b>Rear Axle Tilt Lock Warning</b></p> <p>Telehandler is equipped with rear axle tilt lock.</p>
14		<p><b>Electronic Panel Display Labels</b></p> <p>Indicates park brake, axle lock, secondary brake* and charge pressure status lights. * If equipped</p>
15		<p><b>Washer Fluid*</b></p> <p>Windshield washer fluid label. * If equipped.</p>
16		<p><b>Horn</b></p> <p>Horn label.</p>

Labels - Model ZB2044

Operator's Cab

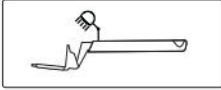





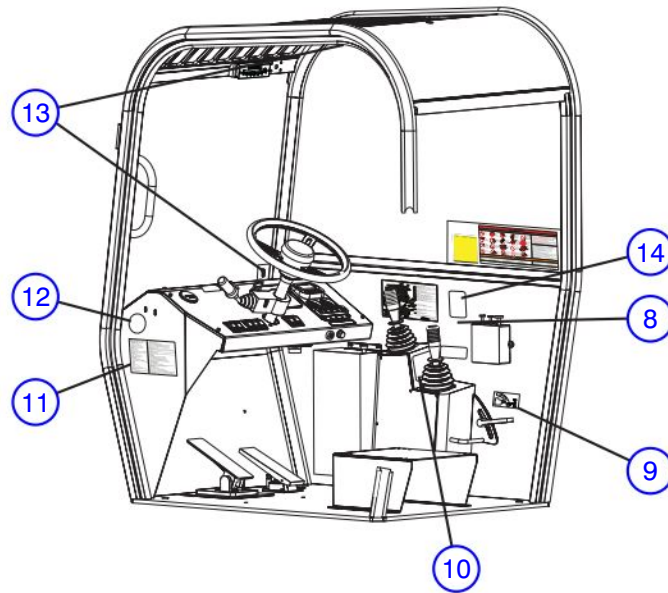

No.	Label Pictorial	Description
1		<p><b>Service Chart</b></p> <p>Identifies the location of grease &amp; service points.</p>
2		<p><b>Forklift Signals</b></p> <p>Follow these directions when assisted by a spotter.</p>
3		<p><b>Hazard Identification</b></p> <p>Read and understand the outlined risks associated with this telehandler prior to operation.</p>
4		<p><b>Head/Tail Lights*</b></p> <p>Identifies the location of light switches. * If equipped.</p>
5		<p><b>Boom Work Lights*</b></p> <p>Identifies the location of light switches. * If equipped.</p>
6		<p><b>Cab Roof Lights*</b></p> <p>Identifies the location of light switches. * If equipped.</p>
7		<p><b>3 Function Joystick (Forks and Chassis)*</b></p> <p>Auxiliary functions joystick. *If equipped.</p>

Labels - Model ZB2044

Operator's Cab (Continued)





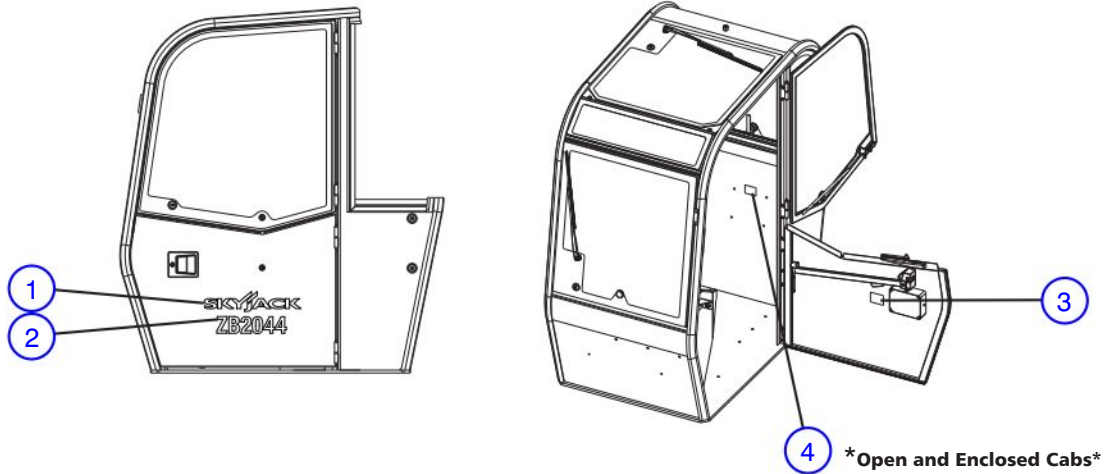

No.	Label Pictorial	Description
8		<p><b>3 Function Joystick (Attachment)*</b>                      Auxiliary attachment functions joystick.                      *Label will vary, may not be as shown (if equipped).</p>
9		<p><b>Tilt-console lock</b>                      Location of tilt-console lock lever.</p>
10		<p><b>3 Function Joystick (Boom)</b>                      Boom and fork tilt functions joystick.</p>
11		<p><b>Daily Check Label</b>                      Check daily before operating the telehandler.</p>
12		<p><b>No Jewelry</b>                      Caution - Do not wear jewelry.</p>
13		<p><b>Washer Fluid*</b>                      Windshield washer fluid label.                      * If equipped.</p>
14		<p><b>Warning - California Proposition 65</b>                      Cancer and Reproductive Harm  <a href="https://www.p65warnings.ca.gov/">https://www.p65warnings.ca.gov/</a></p>

Labels - Model ZB2044



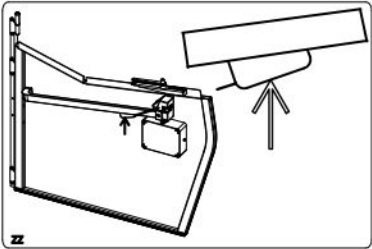



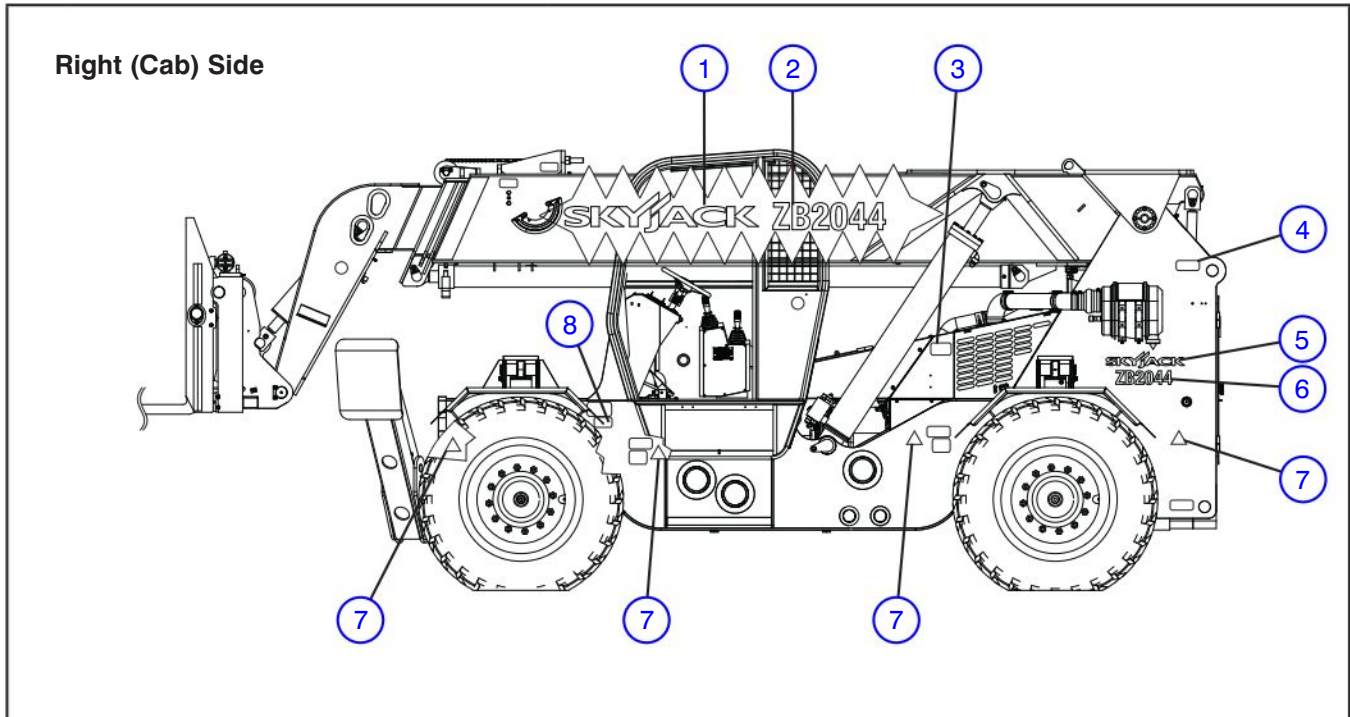

Operator's Cab (Enclosed Cab Only)



No.	Label Pictorial	Description
1		<p><b>Skyjack Logo</b> Skyjack logo - white</p>
2		<p><b>Model Number</b> Product Identifier.</p>
3		<p><b>Open Door</b> Squeeze to open cab door.</p>
4		<p><b>Manual Storage Box</b> Indicates location of operating manual.</p>

Labels - Model ZB2044







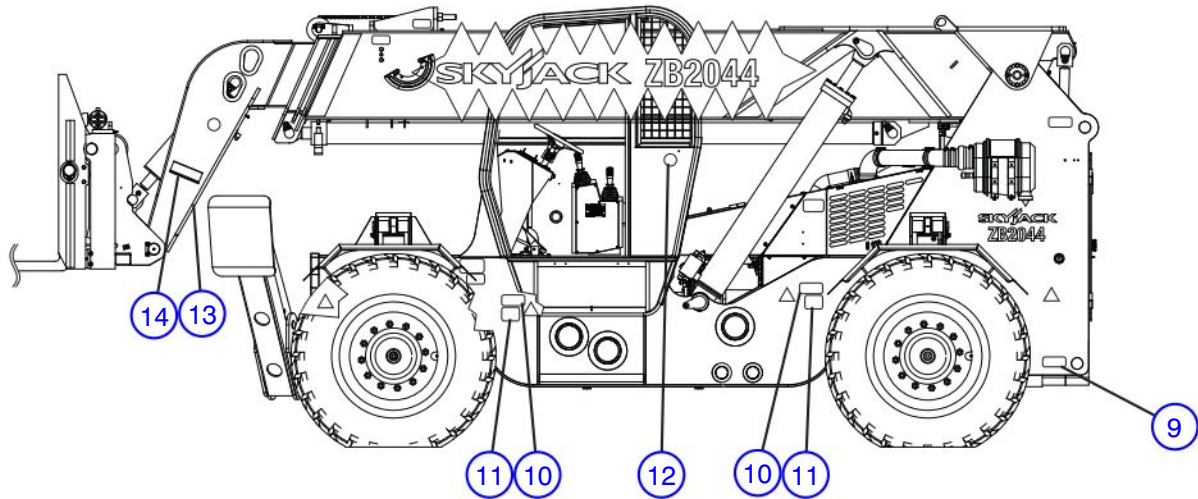

No.	Label Pictorial	Description
1		<b>Skyjack Logo</b> Skyjack logo - white
2		<b>Model Number</b> Product Identifier.
3		<b>Crushing Hazard</b> Refer to operating manual for crushing hazards.
4		<b>Lift and Tie Down Points</b> Only use these points for lifting or tying down.
5		<b>Skyjack Logo</b> Skyjack logo - white
6		<b>Model Number</b> Product Identifier.
7		<b>Body Crush Hazard</b> Danger - Crushing Hazard.
8		<b>Emission Control Information</b> Engine standard emissions information.

Labels - Model ZB2044

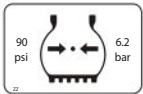

Right (Cab) Side (Continued)

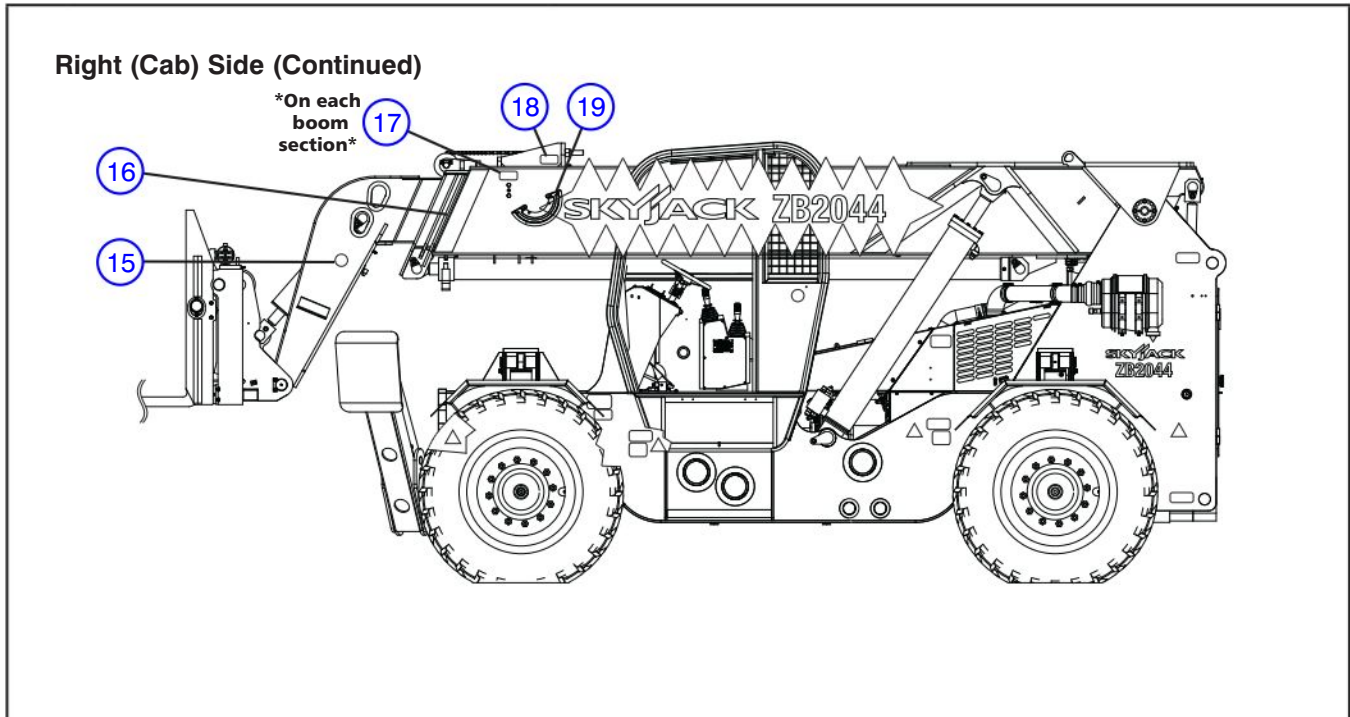

No.	Label Pictorial	Description
9		<p><b>Tie Down Points</b></p> <p>Only use these points for tying down.</p>
10		<p><b>Wheel Information</b></p> <p>Refer to operating manual for wheel information.</p>
11		<p><b>Tire Pressure*</b></p> <p>Inflate tires to 90 psi maximum. * If equipped.</p>
		<p><b>Tire (Foam Filled)*</b></p> <p>Foam filled tires. * If equipped.</p>
12		<p><b>Stay Clear</b></p> <p>Caution - Stay clear.</p>
13		<p><b>Auxiliary 2, 3*</b></p> <p>Indicates auxiliary right/left fork shift. *If equipped</p>
14		<p><b>Auxiliary 1*</b></p> <p>Indicates auxiliary side shift. *If equipped</p>

Labels - Model ZB2044

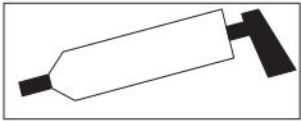
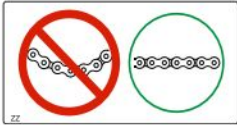

No.	Label Pictorial	Description
15		<p><b>Fork Danger</b> Caution - Fork danger decal.</p>
16	<p>BCDEFG</p>	<p><b>Boom Letters</b> Indicates boom extension distance.</p>
17		<p><b>Grease</b> Grease point.</p>
18		<p><b>Keep Chains Tight*</b> Maintain tension in chains. *If equipped</p>
19		<p><b>Boom Angle Indicator</b> Indicates boom elevation angle.</p>





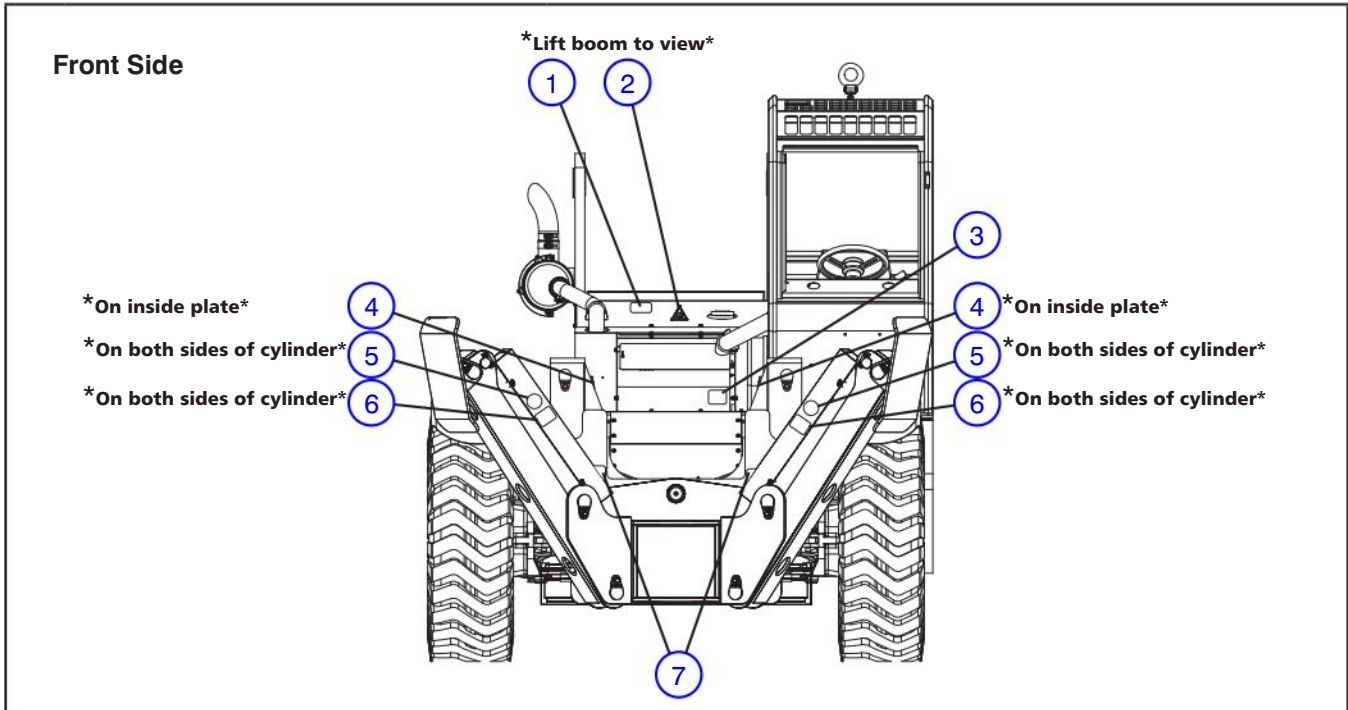



Labels - Model ZB2044

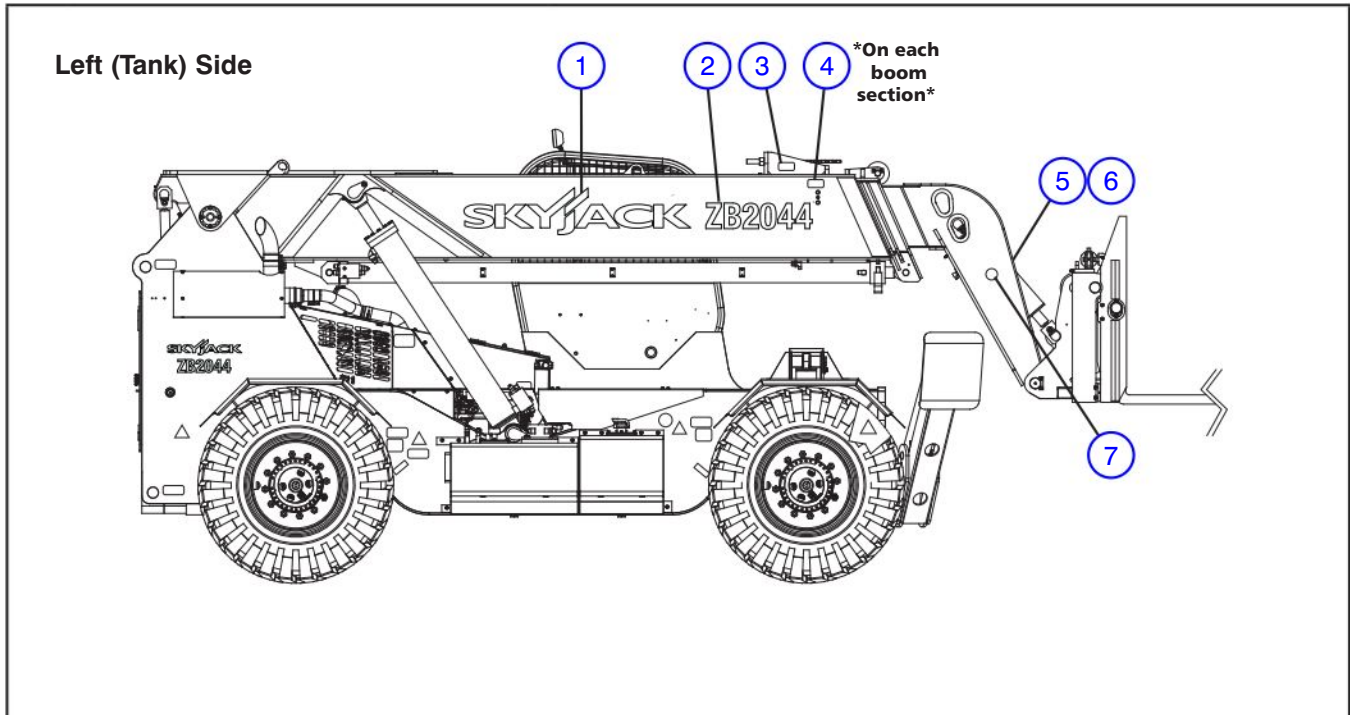

No.	Label Pictorial	Description
1		<b>Caution!</b> Pressurized cooling system - Remove cap slowly.
2		<b>Read Your Operating Manual</b> Refer to the coolant level maintenance section of this manual.
3		<b>Oil Type Label</b> Transmission dipstick and filler tube ATF Dexron III.
4		<b>Grease</b> Grease point.
5		<b>Stay Clear</b> Caution - Stay clear.
6		<b>Crushing Hazard</b> Danger - Crushing hazard.
7		<b>Lift and Tie Down Points</b> Only use these points for lifting or tying down.

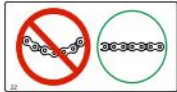
Labels - Model ZB2044







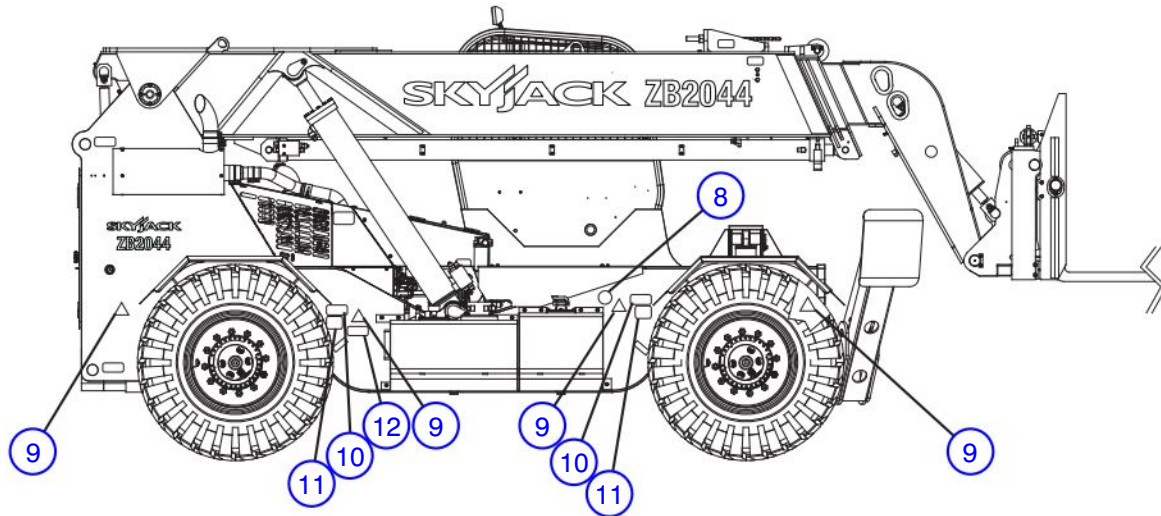

No.	Label Pictorial	Description
1		<b>Skyjack Logo</b> Skyjack logo - white
2		<b>Model Number</b> Product Identifier.
3		<b>Keep Chains Tight*</b> Maintain tension in chains. *If equipped
4		<b>Grease</b> Grease point.
5		<b>Stay Clear</b> Caution - Stay clear.
6		<b>Crushing Hazard</b> Danger - Crushing hazard.
7		<b>Fork Danger</b> Caution - Fork danger decal.

Labels - Model ZB2044

Left (Tank) Side (Continued)







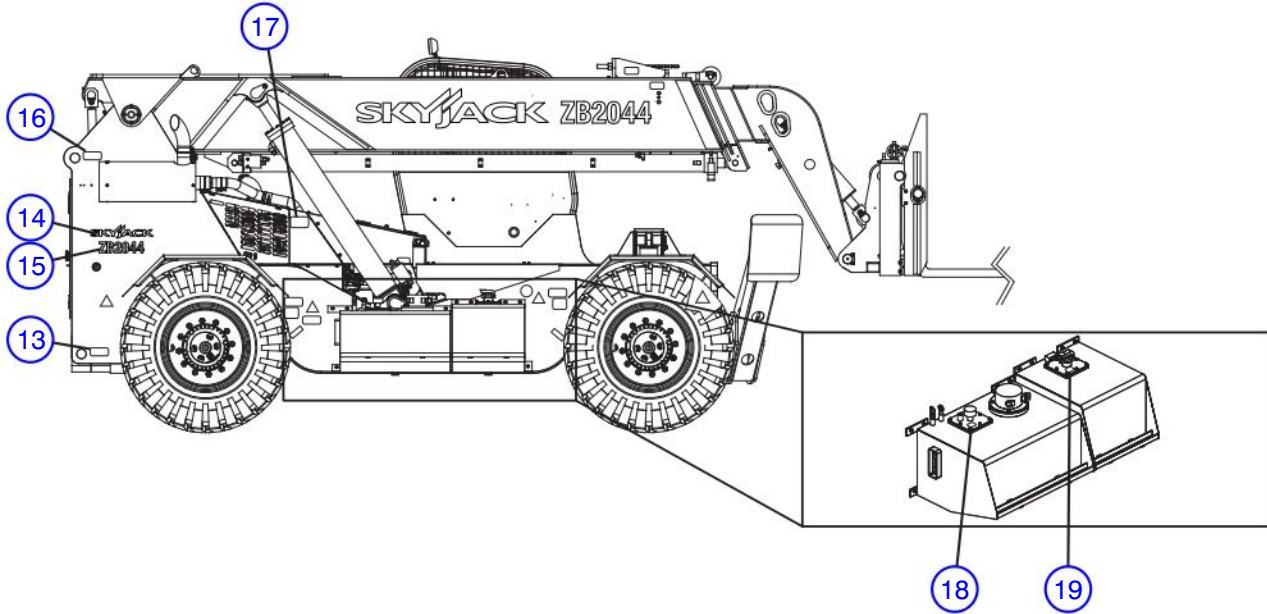

No.	Label Pictorial	Description
8		<p><b>No Smoking</b> No smoking near fuel tank.</p>
9		<p><b>Body Crush Hazard</b> Danger - Crushing Hazard.</p>
10		<p><b>Wheel Information</b> Refer to operating manual for wheel information.</p>
11		<p><b>Tire Pressure*</b> Inflate tires to 90 psi maximum. * If equipped.</p>
11		<p><b>Tire (Foam Filled)*</b> Foam filled tires. * If equipped.</p>
12		<p><b>In-Tank Oil Heater*</b> Model equipped with in-tank oil heater. * If equipped.</p>

Labels - Model ZB2044

Left (Tank) Side (Continued)



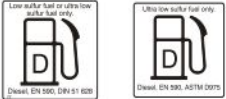

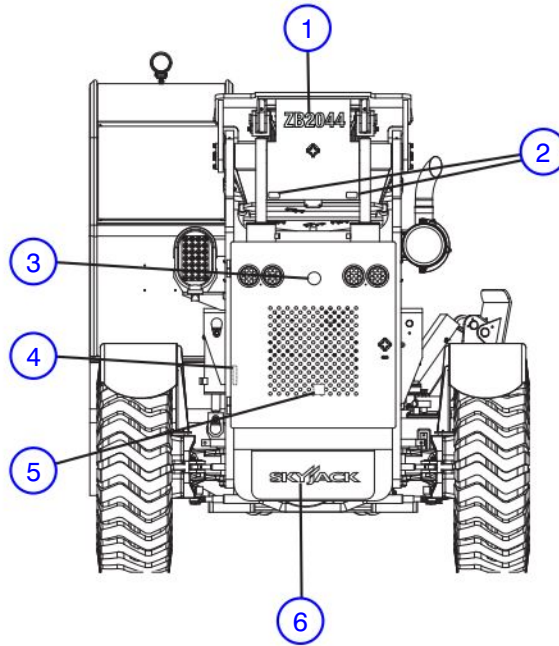

No.	Label Pictorial	Description
13		<p><b>Tie Down Points</b> Only use these points for tying down.</p>
14		<p><b>Skyjack Logo</b> Skyjack logo - white</p>
15		<p><b>Model Number</b> Product Identifier.</p>
16		<p><b>Lift and Tie Down Points</b> Only use these points for lifting or tying down.</p>
17		<p><b>Crushing Hazard</b> Refer to operating manual for crushing hazards.</p>
18		<p><b>Hydraulic Oil</b> Refill Hydraulic oil tank with all weather type hydraulic oil.</p>
19		<p><b>Diesel Fuel Type</b> Refill fuel tank with the appropriate diesel fuel type.</p>

Labels - Model ZB2044

Back Side

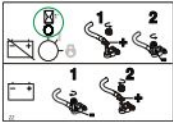

No.	Label Pictorial	Description
1		<b>Model Number</b> Product Identifier.
2		<b>Grease</b> Grease point.
3		<b>Stay Clear</b> Caution - Stay clear.
4		<b>Battery Disconnection/Connection Procedure</b> Follow these instructions to connect/disconnect battery.
5		<b>Battery Disconnect Switch*</b> Battery disconnect. *If equipped.
6		<b>Skyjack Logo</b> Skyjack logo - white





**WARNING**

Cancer and Reproductive Harm-  
<https://www.p65warnings.ca.gov/>.

**SKYJACK™**

[www.skyjack.com](http://www.skyjack.com)